

Flow32-1K™ Sap Flow System

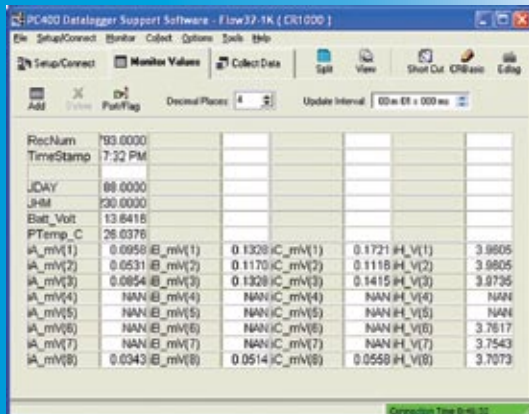

Flow32 - As valuable in the field as it is in the laboratory or greenhouse



Software Features

- Auto Zero Set of Ksh, built in the logger program
- Sap flow data recalculation
- Auto charting graphics - Excel and Quickview
- Power conservation settings
- Low Flow Temperature Cut Off
- Noise Suppression Frequency Adjustment
- Sensor status codes
- Power save & warm up

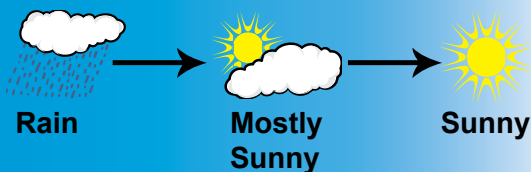

Dynagage Respected Throughout the World

The Dynagage Flow32-1K Sap Flow system and Dynagage sensors have been servicing research plant scientists throughout the world for over 10 years. The Flow32-1K software makes working with Flow32-1K sap flow system easier than ever before with built-in algorithms for efficient and faster data analysis. New powerful functions include auto-zero and sensor status built into the datalogger program. Sap flow data recalculation and automatic charting with an Excel™ Macro link makes the system a superior water relations measurement system. Sap Flow has never been this easy and powerful.

Dynagage sap flow sensors are the most accurate and reliable sensors available for measuring plant sap flow. Dynagage is now a key technique in modern water management, hydrology, crop studies, plant water relations, and biomass production.

Applications

Sap flow measurements have an almost unlimited number of applications. Sap flow and transpiration rates provide commercial benefits from accurate irrigation schedules, improved irrigation set points and real crop ET coefficients. Sap flow is key data to model annual forest growth rates and conduct environmental remediation projections. After all, who can tell better than the plant how much water is consumed under varying conditions.

Below are examples of research and commercial industries where the Flow32 Sap Flow System is actively applied:

- Agriculture
- Crop Physiology
- Forestry
- Horticulture
- Irrigation
- Orchards
- Urban Forestry

- Agroforestry
- Environmental Sciences
- Genetic Engineering
- Hydrology
- Mining Rehabilitation
- Phytoremediation
- Viticulture

Features

- Real-time sap flow
- Direct transpiration readings
- 8 months of data memory capacity for sap flow calculations
- Modular and expandable system

NEW and Improved Features

- Auto Ksh, auto zero algorithm built in
- AVR D high efficiency regulator
- Easy to use logger support software, PC400
- 4 MB Data storage memory



Flow32-1K™ Specifications

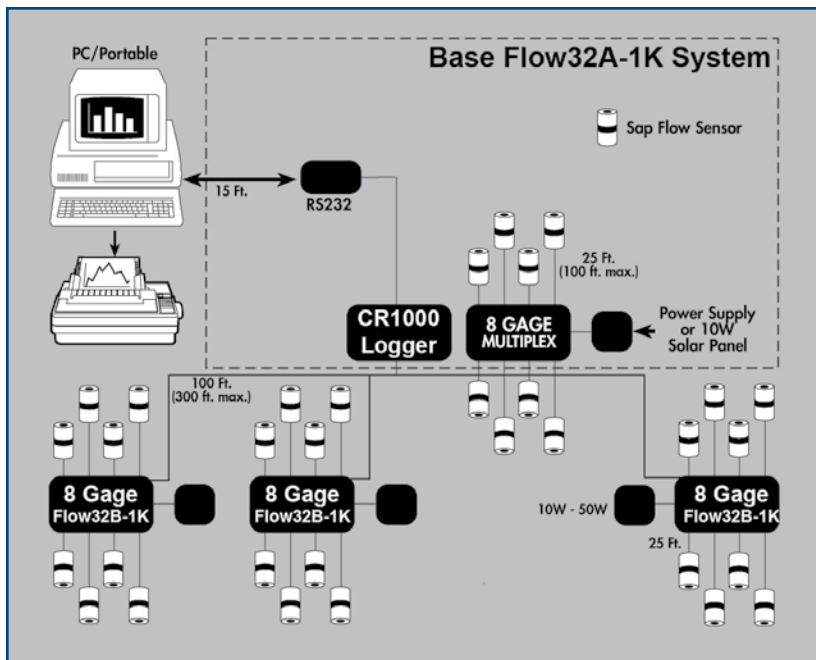

The Base Flow32A-1K system measures up to 8 plants. By adding a combination of Flow32-B, 32 plants can be monitored and sap flow logged for each plant.

Flow32 System Specifications

Datalogger	CR1000 logger with built-in sap flow calculator
Base Inputs	8 Differential Channels - Analog, SDI-12
Channel Expansion	AM16/32 Relay Multiplexer
Expanded Inputs	32 Differential Channels - Analog
Sensor Capacity	(8) Dynagages up to (32) sensors with expansion
Range & Resolution	± 2.5 mV, 0.33 µV to ± 2.5 mV
Voltage Regulation	AVRD Dual Voltage, 1.5 - 10 V, 5 A each
Base Memory	2 Mb
	Hourly data - 1 year
	Daily data - 1 year
	Sap flow calculation - 8 months for 8 gages
Expanded Memory	4 Mb built-in option
Communications	9-PIN Male RS-232 Serial Cable, 15 ft (5m)
Battery	7 Ahr / 12 V Sealed Lead Acid
Charger	120 V AC, 6 A
	220 V AC, 4.5 A
Sensor Cables	8 x 7.6 m (25 ft) with Connectors
Enclosure	White fiberglass, NEMA 4X, with pole mounts, lockable, 17 x 14 x 6.5" (43 x 35 x 16 cm)
System Weight	11.5 kg
System Modules	Sensor Totals

Flow32A-1K	= 8 gages
+ Flow32B-1K	= 16 gages
+ Flow32B-1K	= 24 gages
+ Flow32B-1K	= 32 gages

Ordering Information

The base Flow32A-1K system does not include gages and is configured with eight 7.6 m (25 ft) long sensor cables.

Please apply the solar panel calculations spreadsheet available at www.dynamax.com/support.htm or ask a customer representative for assistance. To complete your order, choose a selection of gage sizes suitable for your application. (8) 25 ft. gage cables are supplied with each Flow32 module. Extensions are available at 25, 50, 75, and 100 ft lengths with quick connect (Model: EXQC-XX).

Main Components

- Flow32A-1K** - 8 Gage System without Gages. Includes software and manuals
- Dynagages** - Select Gage Sizes and Quantity
- PC-LOG** - PC400, PC support software for CR1000 loggers
- PC-LOGNET** - LoggerNet, PC support software for CR1000 loggers

Optional Items

- Flow32B-1K** - Eight Gage expansion kit
- EXQC-XX** - Extra Cable Length XX', available in lengths 25', 50', 75', and 100'.
- EQC-XX/LR** - Special cable for SGA100 or SGA150
- MSX30R** - 30 Watt Solar Panel
- MSX60R** - 60 Watt Solar Panel
- CHG120** - Spare 12 V Battery and Charger 120 V
- CHG220** - Spare 12 V Battery and Charger 220 V
- BA7A** - Spare 7 Ahr Sealed Lead/Acid Battery
- TFE1** - Ease Release spray compound (8oz, 225 ml)

Communication Options

- DNX9600** - 9600 Baud MODEM
- SHM115** - Short-haul RS-232 modem, 2 miles @ 9600 bps
- RFMX09-MK, RFXM24-MK** 900 MHz/ 2.4 GHz RF modem kit. 20 miles (LOS). Includes: 11 dB High-gain antenna, Surge Protector, 15' coaxial cable, 5 Ahr battery, RS-232 cable 6' long, Assembled in a weather-proof enclosure, mount kit.
- GSM-F1-CMK, GSM-F2-CMK** GSM Cellular modem kit includes, Dual-band GSM-cellular modem with all cables, Cellular Yagi/Dual band Omni antenna, Surge Protector, Battery 5 Ahr, 15' Coaxial cable.

Dynamax, Inc.

10808 Fallstone Rd., #350
Houston, TX 77099 USA
Tel: 281-564-5100 Fax: 281-564-5200
admin@dynamax.com
www.dynamax.com

