

ES-2

Electrical Conductivity & Temperature Sensor

Operator's Manual



METER

METER Group, Inc. USA

13890-01

METER Group, Inc. USA

2365 NE Hopkins Court
Pullman WA 99163

Phone: 509-332-5600

Fax: 509-332-5158

Website: www.metergroup.com

Email: support.environment@metergroup.com or
sales.environment@metergroup.com

Trademarks

©2018 METER

All Rights Reserved

Contents

1	Introduction	1
1.1	Customer Support	1
1.2	About This Manual	1
1.3	Warranty	2
1.4	Seller's Liability	2
2	About the ES-2	3
2.1	Specifications	3
3	Measurements	5
3.1	Temperature	5
3.2	Electrical Conductivity	5
4	Calibration	6
5	Connecting Sensors	7
5.1	Connecting to METER Logger	7
5.2	Connecting to a Non-METER Logger	8
5.3	Pigtail End Wiring	8
6	Installation	11
6.1	Pipe Water Monitoring	11
6.2	Tank Water Monitoring	11
6.3	Cleaning Method	12
7	Communication	13
7.1	Serial String	13
7.2	SDI-12 Communication	13
7.3	Common SDI-12 Commands	14
7.4	SDI-12 Sensor Bus	14
7.5	SDI-12 Address	14
7.6	Power	15
7.7	Reading	15
8	Troubleshooting	16
9	Declaration of Conformity	17

1 Introduction

METER designed the ES-2 sensor to measure pipe water, tank water (when used with protective cap). A thermistor in thermal contact with the probe provides water temperature, while the screws on the surface of the sensor form a four-electrode array to measure electrical conductivity. This manual should help you understand the sensor features and how to use it successfully.

1.1 Customer Support

There are several ways to contact METER if you ever need assistance with your product, have any questions, or feedback. METER has Customer Service Representatives available to speak with you Monday through Friday, between 7am and 5pm Pacific time.

Note: If you purchased your sensor through a distributor, please contact them for assistance.

Email:

support.environment@metergroup.com or
sales.environment@metergroup.com

Phone:

509-332-5600

Fax:

509-332-5158

If contacting us by email or fax, please include as part of your message your instrument serial number, your name, address, phone, fax number, and a description of your problem or question.

1.2 About This Manual

Please read these instructions before operating your sensor to ensure that it performs to its full potential.

1.3 Warranty

This sensor has a 30-day satisfaction guarantee and a one-year warranty on parts and labor. Your warranty is automatically validated upon receipt of the instrument.

Note: The one year service plan activates when METER ships the instrument and not at the time of purchase.

1.4 Seller's Liability

Seller warrants new equipment of its own manufacture against defective workmanship and materials for a period of one year from the date of receipt of equipment.

Note: We do not consider the results of ordinary wear and tear, neglect, misuse, or accident as defects.

The Seller's liability for defective parts shall in no event exceed the furnishing of replacement parts "freight on board" the factory where originally manufactured. Material and equipment covered hereby which is not manufactured by Seller shall be covered only by the warranty of its manufacturer. Seller shall not be liable to Buyer for loss, damage or injuries to persons (including death), or to property or things of whatsoever kind (including, but not without limitation, loss of anticipated profits), occasioned by or arising out of the installation, operation, use, misuse, nonuse, repair, or replacement of said material and equipment, or out of the use of any method or process for which the same may be employed. The use of this equipment constitutes Buyer's acceptance of the terms set forth in this warranty. There are no understandings, representations, or warranties of any kind, express, implied, statutory or otherwise (including, but without limitation, the implied warranties of merchantability and fitness for a particular purpose), not expressly set forth herein.

2 About the ES-2

2.1 Specifications

Temperature

Accuracy: ± 1 °C

Resolution: 0.1 °C

Range: -40 °C to 60 °C

Bulk Electrical Conductivity

Accuracy: ± 0.01 dS/m or $\pm 10\%$ (whichever is greater)

Resolution: 0.001 dS/m

Range: 0 to 120 dS/m (bulk)

General

Dimensions:

- **ES-2**: 10.9 x 2.4 cm (4.3 x 0.95 in) with 1/2" NPT

Measurement Time: 300 ms (milliseconds)

Power Requirements: 3.6 to 15 VDC, 0.03 mA quiescent, 0.5 mA during 300 ms measurement

Output: Serial (TTL), 3.6 voltage levels or SDI-12

Operating Temperature: -40 to 60 °C

Note: Sensors can be used at higher temperatures. Please contact METER for assistance.

Connector types: 3.5 mm (stereo) plug or stripped and tinned lead wires (Pigtail)

Cable Length: 5 m standard; custom cable length

Data logger Compatibility (not exclusive):

- **METER**: All METER Loggers capable of reading digital sensors

- **Campbell Scientific:** Loggers with serial I.O including CR10X, CR23X, or any CRBasic type logger (CR850, 1000, 3000, etc)
- **Other:** Any data acquisition system capable of 3.6 to 15 V excitation and serial or SDI-12 communication.

Handheld Reader Compatibility: ProCheck (rev 1.34+)

Software Compatibility: ECH₂O Utility (rev 1.64+) and DataTrac 3 (rev 3.4+)

3 Measurements

3.1 Temperature

A thermistor near the electrical conductivity (EC) sensor senses the temperature of the water. The sensor uses this temperature to adjust the EC measurements to their 25 °C value, and provides the temperature output for the data stream.

3.2 Electrical Conductivity

EC is useful for measuring the concentration of salts in water and also gives information about dissolved solids. EC is measured by applying an alternating electrical current to two electrodes, measuring voltage drop with a separate set of electrodes. Then measuring the current flow through those electrodes and measuring the current with a separate set of electrodes. The conductance is the ratio of current to voltage. Conductivity is conductance multiplied by a cell constant based on common conductivity standards. It is important to realize that a four electrode sensor gives unpredictable readings in air because there is no connection between the voltage and current electrodes.

4 Calibration

METER calibrates our EC sensors at the factory using KC1 solutions of known concentration and calibration values are stored internally in flash memory.

The following table relates EC at 25 °C to concentration for various concentrations of KC1. Operators can verify ES-2 performance using these solutions. The ES-2 internally corrects output value to 25 °C

Table 1: EC of KC1 solutions for testing ES-2 calibrations.

Electrical Conductivity ($\mu\text{S}/\text{cm}$)	g KC1 per kg of distilled water
100	0.0446
200	0.0930
500	0.2456
1,000	0.5120
2,000	1.0673
5,000	2.8186
10,000	5.8758
20,000	12.2490

5 Connecting Sensors

The ES-2 Sensor was designed to work most efficiently with METER's data loggers, or our ProCheck handheld reader. The standard sensor (with 3.5 mm stereo connector) quickly connects to and is easily configured within a METER logger or ProCheck.

The ES-2 Sensor incorporates several features that also make it an excellent sensor for use with third party loggers. The sensor may be purchased with stripped and tinned wires (pigtail) for terminal connections. Visit www.metergroup.com and search for the *ES-2 Integrator Guide* to get extensive directions on integrating the ES-2 sensor into third party loggers.

The ES-2 Sensor comes standard with a five meter cable. Sensors may be purchased with custom cable lengths for an additional fee (on a per-meter basis). METER has tested its digital sensors successfully with cable lengths up to 1,000 m (3,200 ft). Using a longer cable eliminates the need for splicing the cable (a possible failure point).

5.1 Connecting to METER Logger

METER designed the ES-2 to work specifically with METER data loggers. Simply plug the 3.5 mm "stereo" connector directly into one of the sensor ports.



Figure 1: 3.5 mm Stereo Plug Wiring

The next step is to configure your logger port for the ES-2 Sensor and set the measurement interval. This may be done using ei-

ther ECH₂O Utility Mobile (see respective manuals). Please check your software version to ensure it supports the ES-2. To upgrade your software to the latest version, please visit METER's website: www.metergroup.com.

The following firmware and software supports the ES-2 Sensor:

Em50 Firmware version 2.09 or greater

ECH₂O Utility 1.64 or greater

ECH₂O DataTrac 3.4 or greater

To download data from the logger to your computer, you need to use the ECH₂O Utility, DataTrac 3 or a terminal program on your computer.

5.2 Connecting to a Non-METER Logger

The ES-2 Sensor may be purchased for use with non-METER data loggers. These sensors typically come configured with stripped and tinned (pigtail) lead wires for use with screw terminals. Refer to your logger manual for details on wiring. Our Integrator's Guide gives detailed instructions on connecting the ES-2 sensor to non-METER loggers. Please visit www.metergroup.com for the complete Integrator's Guide.

5.3 Pigtail End Wiring

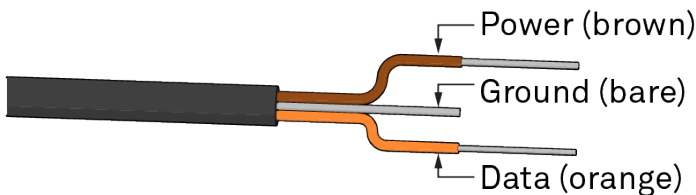

Figure 2: Cable Wiring

Connect the wires to the data logger as shown, with the supply wire (brown) connected to the excitation (3.6 to 15 volts), the digital out

wire (orange) to a digital input, the bare wire (ground) to ground.

NOTE: Some ES-2 sensors may have the older Decagon wiring scheme where the power supply is white, the digital out is red, and the bare wire is ground.

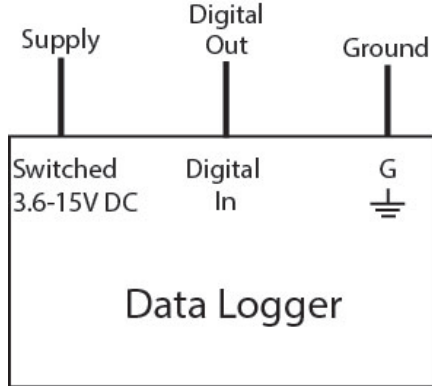

Figure 3: Wiring Diagram

Note: The acceptable range of excitation voltages is from 3.6 to 15 VDC. If you wish to read your METER sensor with the Campbell Scientific Data Loggers, you will need to power the sensors off of the switched 12V port.

If your ES-2 Sensor is equipped with the standard 3.5 mm plug, and you wish to connect it to a non-METER data logger, you have two options. The first option is to clip off the plug on the sensor cable, strip and tin the wires, and wire it directly into the data logger. The advantage of this method is that you create a direct connection with no chance of the sensor becoming un-plugged. However, it then cannot be easily used in the future with a METER readout unit or data logger. (Figure 1)

The second option is to obtain an adapter cable from METER. The 3-wire sensor adapter cable has a connector for the sensor jack on one end, and three wires on the other end for connection to a data logger

(this type of wire is often referred to as a “pigtail adapter”). Both the stripped and tinned adapter cable wires have the same termination as seen above; the brown wire is excitation, orange is output, and the bare and black wires are ground. (Figure 2 and 3)

6 Installation

METER designed the ES-2 sensor for installation in several different applications. The ES-2 can be installed in line with an irrigation pipe, in a water body or in a tank.

Note: Do not remove the protective cap from the sensor. This will change the sensor calibration and result in erroneous data.

6.1 Pipe Water Monitoring

The threaded cap on the ES-2 allows for easy installation into a pipe for monitoring the EC and temperature of water flowing through a pipe.

To integrate the ES-2 into an irrigation pipe, begin by ensuring the white threaded plug is installed on the side of the protective screw cap. Then screw the end of the ES-2 sensor into a 3/4" NPT Tee pipe fitting. If necessary, use a pipe converter to convert from the 3/4" NPT thread size to a size more appropriate for your system.

Orient the sensor with the cable end facing down or to the side. This will allow air to escape from the sensing area.

6.2 Tank Water Monitoring

The ES-2 can be used to monitor water in a storage tank or water body. When used in a tank or water body, the ES-2 should be used with the attached protective screw-on cap. It is best to suspend the sensor in the tank, but if this is not possible, make sure that the sensor is placed away from the sides of the tank as much as possible.

After the sensor is installed in the correct location, follow the instructions in **Cleaning Method**.

A four electrode conductivity measurement is less sensitive to sensor fouling than a two electrode sensor, but contamination of the electrodes can still affect the measurement. The electrodes are stainless steel.

6.3 Cleaning Method

1. Insert swab into slot on side of sensor housing. Rug the screws vigorously with swab.
2. Rinse the sensor and screws thoroughly with tap or DI water

Note: Do not touch the screws without gloves or contact them with any source of oil or other non-conducting residue.

7 Communication

The ES-2 sensor can communicate using two different methods: 1) Serial String or 2) SDI-12 communication protocol. This section discusses the specifics of each of these communication methods. Please visit www.metergroup.com for the complete Integrator's Guide, which gives more detailed explanations and instructions.

7.1 Serial String

When you apply excitation voltage to the ES-2 sensor it makes a measurement. Within about 140 ms of excitation, three measurement values transmit to the data logger as a serial stream of ASCII characters. The serial out is 1,200 baud asynchronous with 8 data bits, no parity, and one stop bit. The voltage levels are 0 to 3.6 V and the logic levels are TTL (active low). The power must be removed and reapplied for a new set of clues to be transmitted.; The ASCII stream contains two numbers separated by spaces. The first number is EC in $\mu\text{S}/\text{cm}$ with a resolution of 1 $\mu\text{S}/\text{cm}$ and the second number is temperature in Celsius with a resolution of 0.1 $^{\circ}\text{C}$ a carriage return follows the three numbers, then the character "t," indicating that this is a ES-2 sensor, then a checksum character, and finally a carriage return and line feed.

7.2 SDI-12 Communication

The ES-2 sensor also communicates using SDI-12 protocol, a three-wire interface where all sensors are powered (brown wire), grounded (bare wire and black wire), and communicate (orange wire) on shared nodes (for more information on the SDI-12 protocol, visit www.sdi-12.org). Below is a brief description of SDI-12 for communication. If you plan on using SDI-12 for communication with the ES-2 Sensor, please see our integrator's guide at www.metergroup.com for detailed instruction.

7.3 Common SDI-12 Commands

Table 2 shows common SDI-12 commands that the ES-2 Sensor responds to. The ES-2 can respond to any SDI-12 command under the SDI-12 specification version 1.3. The sensor addresses shown an ‘a.’ If a ‘?’ is substituted for ‘a’ all addresses respond.

Table 2: SDI-12 Commands

Send Identification	aI!	a13DECAGON ES-2 316<CR><LF>
Change Address	aAb!	b<CR><LF>(b is new address)
Address Query	?!	a<CR><LF>
Start Measurement	aM!	00013<CR><LF>
Send Data	aD0!	a+9+22.2+0<CR><LF>(3 values)

7.4 SDI-12 Sensor Bus

Up to 62 sensors can be connected to the same 12 V supply and communication port on a data logger. This simplifies wiring because no multiplexer is necessary. However, a problem with one sensor can bring down the entire array (though a short circuit or incorrect address settings). If you do use a SDI-12 sensor bus, we recommend that you make an independent junction box with wire harnesses where all sensor wires attach to lugs so sensors can be disconnected individually if a problem arises. A single three-wire cable can be run from the junction box to the data logger. While this method minimizes the number of data loggers needed, it maximizes the need for personnel to monitor the set-up.

7.5 SDI-12 Address

The SDI-12 protocol requires that all sensors have a unique sensor address. ES-2 sensors come from the factory with a SDI-12 address of 0. To add SDI-12 sensors to a system, the sensor address must

be changed for each additional sensor. Address options include 0...9, A...Z, a...z. The best and easiest way to change an address is to use METER's ProCheck (if this option is not available on your ProCheck, please upgrade to the latest version of firmware). SDI-12 addressing can be accessed in the ProCheck CONFIG menu by selecting "SDI-12 Address." You may then change addresses may then be changed by simply pressing the up or down arrows until you see the desired address and pushing Enter.

The SDI-12 communication protocol is supported by Campbell Scientific data loggers like the CR10X, CR200, CR1000, CR3000, etc. Direct SDI-12 communication is supported in the "Terminal Emulator" mode under the "Tools" menu on the "Connect" screen. Detailed information on setting the address using CSI data loggers can be found on our website at <http://www.metergroup.com>.

7.6 Power

The ES-2 can be powered using any voltage from 3.6 to 15 VDC, but 12 V is optimal. Although SDI-12 protocol allows the sensors to be continuously powered, it is often best to connect the power wire (brown) to a switched source. This reduces power usage (although the ES-2 Sensor uses very little power) and reset the sensor from time to time.

7.7 Reading

Example programs from Edlog and CRBasic can be found in our software section online at www.metergroup.com. As with the Serial String, the water depth is the first number output by the sensor in mm. The second number is temperature in Celsius. The third number is EC, in $\mu\text{S}/\text{cm}$.

8 Troubleshooting

Problems with the ES-2 sensor generally manifest as incorrect or erroneous readings. Before contacting METER about the sensor, try the following:

Data Logger

1. Check to make sure the connections to the data logger are both correct and secure.
2. Verify that your data logger batteries are not dead or weakened.
3. Check the configuration of your data logger in ECH₂O Utility or DataTrac to make sure you have selected the ES-2 sensor on the correct port.
4. Verify that you are using the most up to date software and firmware. You can find the most up to date version of the software and firmware at www.metergroup.com/contact/.

Sensors

1. Verify that your sensors are installed according to the “Installation” section of this manual
2. Check sensor cables for nicks or cuts the could cause a malfunction
3. Check the pressure transducer tube to ensure that it is not clogged or damaged.

9 Declaration of Conformity

Application of Council Directive: 2004/108/EC and 2011/65/EU

Standards to which conformity
is Declared EN61326-1: 2013
EN50581: 2012

Manufacturer's Name: METER Group, Inc. USA
2365 NE Hopkins Court
Pullman, WA 99163 USA

Type of Equipment: Water Depth Sensor

Model Number: ES-2

Year of First Manufacture: 2012

This is to certify that the ES-2 manufactured by METER Group, a corporation based in Pullman, Washington, USA meets or exceed the standards for CE compliance as per the Council Directives noted above. All instruments are built at the factory. Pertinent testing documentation is freely available for verification.

Index

Calibration, 6

Cleaning method, 12

Contact Information, 1

Customer Support, 1

Declaration of conformity, 17

Electrical conductivity, 3

Email, 1

Installation, 11

 Monitoring a Tank, 11

 Water In a Pipe, 11

Power Requirements, 3

Protective cap, 11

SDI-12 Communication, 13

Seller's Liability, 2

Sensor Cleaning, 11

Serial String, 13

Specifications, 3

Temperature, 5

Warranty, 2