



METER

TEROS 12



TABLE OF CONTENTS

1. Introduction.....	1
2. Operation	2
2.1 Installation.....	2
2.2 Connecting.....	7
2.2.1 Connect to METER Data Logger	7
2.2.2 Connect to a Non-METER Logger	8
2.3 Communication	9
3. System.....	10
3.1 Specifications	10
3.2 Components.....	13
3.3 Theory	14
3.3.1 Volumetric Water Content	14
3.3.2 Temperature.....	15
3.3.3 Electrical Conductivity	15
3.3.4 Converting Bulk EC to Pore EC.....	15
3.3.5 Pore Water Versus Saturation Extract EC	16
4. Service.....	18
4.1 Calibrations.....	18
4.1.1 Mineral Soils	18
4.1.2 Soilless Media.....	18
4.1.3 Apparent Dielectric Permittivity	19
4.2 Cleaning	19
4.3 Troubleshooting.....	19

4.4 Customer Support20

4.5 Terms and Conditions21

References 22

Index 23

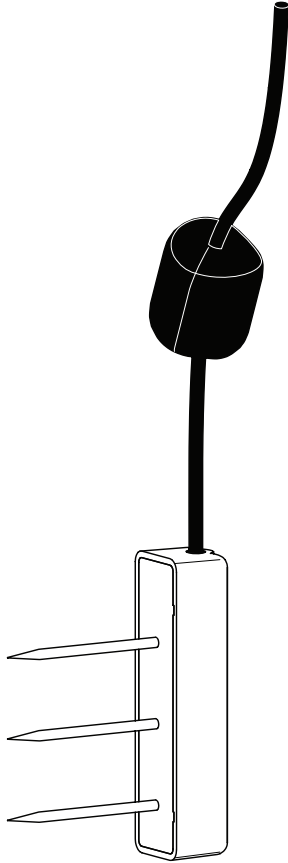

1. INTRODUCTION

Thank you for choosing the TEROS 12 Soil Moisture and Electrical Conductivity (EC) and Temperature sensor.

The TEROS 12 sensor is designed to be installed in mineral soils, many types of growing media, and other porous materials. This manual guides the customer through the sensor features and describes how to use the sensor successfully.

TEROS 12 APPLICATIONS

- Volumetric water content (VWC) measurement
- Soil/substrate water balance
- Irrigation management
- Soil EC measurement
- Soil/substrate temperature measurement
- Solute/fertilizer movement

Prior to use, verify the TEROS 12 arrived in good condition. METER recommends testing the sensors with the data logging device and software before going to the field.

2. OPERATION

Please read all instructions before operating the TEROS 12 to ensure it performs to its full potential.

⚠ SAFETY PRECAUTIONS

METER sensors are built to the highest standards. Misuse, improper protection, or improper installation may damage the sensor and possibly void the manufacturer's warranty. Before integrating the TEROS 12 into a system, follow the recommended installation instructions and have the proper protections in place to safeguard sensors from damage. If installing sensors in a lightning-prone area with a grounded data logger, see the application note [Lightning surge and grounding practices](#).

2.1 INSTALLATION

Follow the steps listed in [Table 1](#) to set up the TEROS 12 and start collecting data. For more detailed installation information consult the [TEROS Sensors Best Practices Installation Guide](#).

Table 1 Installation

<p>Tools Needed</p>	<p>Auger or Shovel</p>
	<p>Secure Mounting Location for Data Logger and Cable</p>
	<p>Optional Tool</p>
	<p>Borehole Installation Tool</p> 

Table 1 Installation (continued)

Preparation	<p>Determine Best Installation Method There are several methods for installing soil moisture sensors. These methods are described in Table 2.</p> <p>Avoid Putting any Metal in Between the Sensor and the Ferrite Core Any metal located between the sensor and the ferrite core can interfere with the TEROS 12 VWC measurement.</p> <p>Check Sensor Functionality Plug the sensor into the data logger (Section 2.2) to make sure the sensor is operating as expected.</p> <p>Conduct System Check Verify all sensors read within expected ranges. To validate both sensor function and logger functionality, take a sensor measurement in air and water. The TEROS 12 will read $-0.70 \text{ m}^3/\text{m}^3$ in water and a slightly negative value in air.</p>
	<p>There are several methods for installing soil moisture sensors (Table 2). Keys to a good installation and collecting good soil moisture data are described below.</p> <p>Create Hole Avoid interfering objects. If the TEROS 12 is installed near large metal objects they can affect the sensor function and distort readings. Avoid large objects like roots or rocks that could potentially bend the needles. Auger or trench a hole to the desired sensor installation depth and direction according to the installation method desired.</p> <p>Insert Sensor ATTENTION! Minimize air gaps around the sensor. Air gaps around the sensor needles will result in low readings of soil moisture.</p> <ol style="list-style-type: none"> 1. Load the TEROS 12 using the Borehole Installation Tool (BIT). NOTE: The BIT provides a significant amount of mechanical advantage. See Table 2 for instruction on installing the TEROS 12 without the BIT. 2. Lower the tool into the hole or trench with the back of the tool supported by the far wall. 3. Pull the tool lever to activate the jack and insert the sensor into the sidewall. <p>WARNING: When installing sensors in rocky soils, use care to avoid bending sensor needles. The soil closest to the sensor has the strongest influence on readings. It is ideal to install the sensor in the native soil to get accurate soil moisture readings.</p>
Installation	

Table 1 Installation (continued)

Sensor orientation. When the TEROS 12 sensor is installed, it may be positioned in any direction (needles aligned horizontally or vertically). However, installing the sensors with the needles in a horizontal position (as shown below) will provide the least restriction to water flow through soil because the water will flow through the soil directly to the needles.

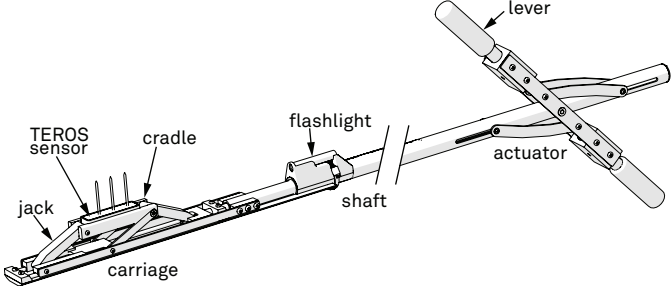
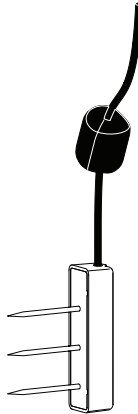

Sensor body vertical and needles horizontal

Because of the shape of the sensor electromagnetic field, installing the sensor with the body oriented vertically will integrate more soil depth into the soil moisture measurement. Installing the sensor with the body oriented horizontally (on its side) will provide measurements at a more discreet depth. See [Measurement volume of METER volumetric water content sensors](#) for more information on sensor measurement volume.

Backfill the Hole

Return soil to the hole, packing the soil back to its native bulk density.

Do not hit the ferrite core as this could potentially pull the sensor out of the soil.

Connect to Logger

Connect the 3.5-mm stereo plug connector into a stereo port on METER data logger.

METER data loggers will automatically recognize TEROS sensors.

Use ZENTRA Utility software ([Section 2.2](#)) to configure desired measurement intervals and verify proper sensor identification by the logger.

Click SCAN in ZENTRA Utility to verify the TEROS 12 is active and providing reasonable readings based on soil conditions.

Verify that these readings are reasonable based on soil conditions.

To connect to a non-METER data logger, refer to the [TEROS 12 Integrator Guide](#).

Installation
(continued)

Table 1 Installation (continued)**Secure and Protect Cables**

Secure and protect cables with PVC casing or flexible conduit to protect against damage from rodents or driving over sensor cables.

Secure Excess Cable

To prevent loose cabling from being inadvertently snagged or tripped over, gather and secure excess cable to the mounting mast in one or more places. Tie excess vertical cable to the data logger mast to ensure cable weight does not cause sensor to unplug.

Relieve Cable Strain

To relieve strain on the connections, leave the cables a little loose between the logger and the closest secured point on the mast. This will allow for thermal expansion and contraction of the cable without potentially pulling the stereo connection out of the logger.

Installation
(continued)

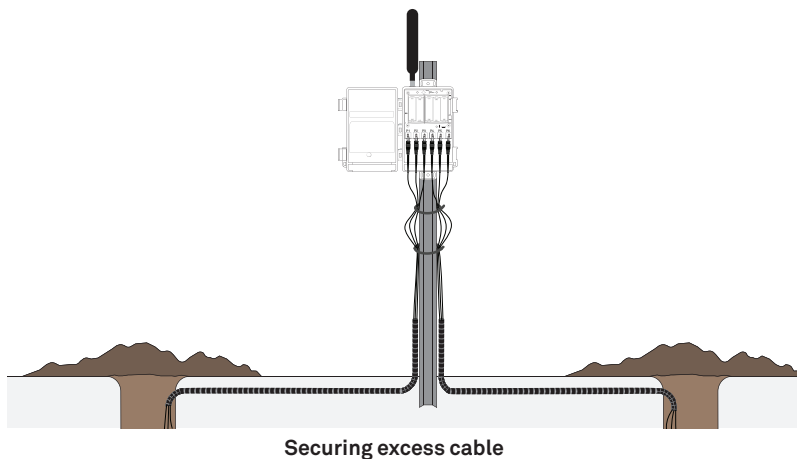
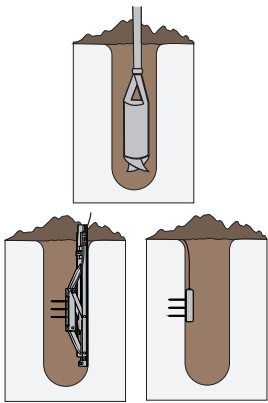
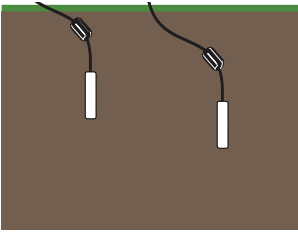

Table 2 contains brief descriptions for typical installation methods. Each has its own advantages and disadvantages. For more information about which installation method is best for specific applications, please see the [TEROS 12 Installation Guide](#) or contact [Customer Support](#).

Table 2 Installation methods

Borehole			
<p>This method uses the Borehole Installation Tool (Table 1) that allows a profile of soil moisture sensors to be installed at different depths within a single augered borehole. A 10-cm (4-in) borehole is augered vertically at the measurement location. The Borehole Installation Tool is then used to install the sensors in the sidewall of the borehole.</p> <p>NOTE: The borehole method requires specialized installation tool available from METER if installing at depths greater than 50 cm.</p>		<p>Advantage</p> <p>Minimizes soil disturbance at measurement site.</p>	<p>Disadvantage</p> <p>Requires a specialized installation tool that can be rented from METER.</p>
Trench			
<p>The trench installation method is best for shallow installations (less than 40 cm). This requires digging a trench with a shovel, excavator, etc. The trench needs to be dug to the depth of the deepest installed sensor. For deep installations, this may require a large trench. The sensor is then installed carefully by hand into the undisturbed soil of the trench sidewall. The trench is then carefully backfilled to preserve the bulk density of the soil and to avoid dislodging the installed sensor by accidentally snagging the ferrite core.</p>		<p>Advantage</p> <p>Does not require specialized equipment.</p>	<p>Disadvantage</p> <p>Large soil disturbance at measurement site.</p> <p>Potentially large excavation effort.</p>

2.2 CONNECTING

The TEROS 12 works most efficiently with METER ZENTRA, EM60, or Em50 data loggers. The TEROS 12 can also be used with other data loggers, such as those from Campbell Scientific, Inc. For extensive directions on how to integrate the sensors into third-party loggers, refer to the [TEROS 12 Integrator Guide](#).

TEROS 12 sensors require an excitation voltage in the range of 4 to 15 VDC and operate at a 4 VDC level for data communication. TEROS 12 can be integrated using SDI-12 protocol. See the [TEROS 12 Integrator Guide](#) for details on interfacing with data acquisition systems.

TEROS 12 sensors that are ordered for use with ZENTRA, EM60, or Em50 data loggers come with a 3.5-mm stereo plug connector ([Figure 1](#)) to facilitate easy connection with METER loggers.



Figure 1 Stereo plug connector

The TEROS 12 sensor comes standard with a 5-m cable. It may be purchased with custom cable lengths for an additional fee (on a per-meter basis). This option eliminates the need for splicing the cable (a possible failure point). However, the maximum recommended length is 75 m.

2.2.1 CONNECT TO METER DATA LOGGER

The TEROS 12 sensor works seamlessly with METER ZENTRA, EM60, or Em50 data loggers. Logger configuration may be done using either ZENTRA Utility (desktop and mobile application) or ZENTRA Cloud (web-based application for cell-enabled ZENTRA data loggers).

1. Plug the 3.5-mm stereo plug connector into one of the sensor ports on the logger.
2. Using the appropriate software application, configure the chosen logger port for TEROS 12.
3. Set the measurement interval.

ZENTRA, EM60, or Em50 data loggers measure the TEROS 12 every minute and return the minute-average data across the chosen measurement interval. TEROS 12 data can be downloaded from these loggers using either ZENTRA Utility (desktop and mobile application) or ZENTRA Cloud (web-based application for cell-enabled data loggers).

2.2.2 CONNECT TO A NON-METER LOGGER

The TEROS 12 can be used with non-METER (third-party) data loggers. Refer to the third-party logger manual for details on logger communications, power, and ground ports. The [TEROS 12 Integrator Guide](#) provides detailed instructions on connecting sensors to non-METER loggers.

TEROS 12 sensors can be ordered with stripped and tinned (pigtail) connecting wires for use with screw terminals. Connect the TEROS 12 wires to the data logger illustrated in [Figure 2](#), with the supply wire (brown) connected to the excitation, the digital out wire (orange) to a digital input, and the bare ground wire to ground.

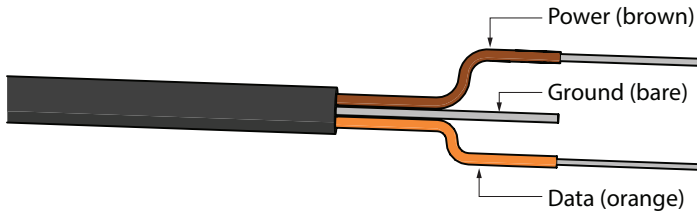

Figure 2 Pigtail wiring

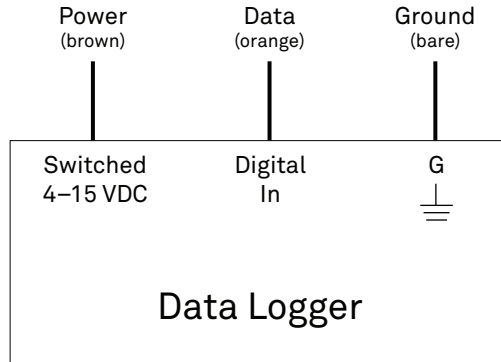

Figure 3 Wiring diagram

NOTE: The acceptable range of excitation voltages is from 4 to 15 VDC. To read TEROS 12 sensors with Campbell Scientific, Inc. data loggers, power the sensors from a switched 12 V port or a 12 V port if using a multiplexer.

If the TEROS 12 cable has a standard 3.5-mm stereo plug connector and will be connected to a non-METER data logger, please use one of the following two options.

Option 1

1. Clip off the 3.5-mm stereo plug connector on the sensor cable.
2. Strip and tin the wires.
3. Wire it directly into the data logger.

This option has the advantage of creating a direct connection with no chance of the sensor becoming unplugged. However, it then cannot be easily used in the future with a METER readout unit or data logger.

Option 2

Obtain an adapter cable from METER.

The adapter cable has a connector for the stereo plug connector sensor jack on one end and three wires (or pigtail adapter) on the other end for connection to a data logger. The stripped and tinned adapter cable wires have the same termination as seen in [Figure 3](#); the brown wire is excitation, the orange is output, and the bare wire is ground.

NOTE: Secure the 3.5-mm stereo plug connector to the pigtail adapter connections to ensure the sensor does not become disconnected during use.

2.3 COMMUNICATION

The TEROS 12 sensor communicates using two different methods:

DDI serial string

SDI-12 communication protocol

To obtain detailed instructions, read the [TEROS 12 Integrator Guide](#).

3. SYSTEM

This section reviews the components and functionality of the TEROS 12 sensor.

3.1 SPECIFICATIONS

MEASUREMENT SPECIFICATIONS

Volumetric Water Content (VWC)

Range

Mineral soil calibration 0.00–0.70 m³/m³

Soilless media calibration 0.0–1.0 m³/m³

Apparent dielectric permittivity (ϵ_a) 1 (air) to 80 (water)

NOTE: The VWC range is dependent on the media the sensor is calibrated to. A custom calibration will accommodate the necessary ranges for most substrates.

Resolution 0.001 m³/m³

Accuracy

Generic calibration ± 0.03 m³/m³ typical in mineral soils that have solution EC <8 dS/m

Medium specific calibration ± 0.01 – 0.02 m³/m³ in any porous medium

Apparent dielectric permittivity (ϵ_a) 1–40 (soil range), $\pm 1 \epsilon_a$ (unitless)
40–80, 15% of measurement

Dielectric Measurement Frequency

70 MHz

Temperature

Range –40 to 60 °C

Resolution 0.1 °C

Accuracy ± 1 °C

Bulk Electrical Conductivity (EC_b)

Range 0–10 dS/m (bulk)

Resolution 0.001 dS/m

Accuracy $\pm 5\%$ of measurement

Output

DDI serial or SDI-12 communications protocol

Data Logger Compatibility

Any data acquisition system capable of 4.0- to 15-VDC power and serial or SDI-12 communication

PHYSICAL SPECIFICATIONS**Dimensions**

Length 9.4 cm (3.70 in)

Width 2.4 cm (0.95 in)

Height 7.5 cm (2.95 in)

Needle Length

5.5 cm (2.17 in)

Cable Length

5 m (standard)

75 m (maximum custom cable length)

NOTE: Contact [Customer Support](#) if a nonstandard cable length is needed.

Connector Types

3.5-mm stereo plug connector or stripped and tinned wires

ELECTRICAL AND TIMING CHARACTERISTICS**Supply Voltage (VCC to GND)**

Minimum 4.0 VDC

Typical NA

Maximum 15.0 VDC

Digital Input Voltage (logic high)

Minimum 2.8 V

Typical 3.6 V

Maximum 3.9 V

Digital Input Voltage (logic low)

Minimum	-0.3 V
Typical	0.0 V
Maximum	0.8 V

Power Line Slew Rate

Minimum	1.0 V/ms
Typical	NA
Maximum	NA

Current Drain (during 25-ms measurement)

Minimum	3.0 mA
Typical	3.6 mA
Maximum	16.0 mA

Current Drain (while asleep)

Minimum	NA
Typical	0.03 mA
Maximum	NA

Operating Temperature Range

Minimum	-40 °C
Typical	NA
Maximum	60 °C

NOTE: Sensors may be used at higher temperatures under certain conditions; contact [Customer Support](#) for assistance.

Power-Up Time (DDI serial)

Minimum	80 ms
Typical	NA
Maximum	100 ms

Power-Up Time (SDI-12)

Minimum	NA
Typical	245 ms
Maximum	NA

Measurement Duration	
Minimum	25 ms
Typical	NA
Maximum	50 ms

COMPLIANCE

Manufactured under ISO 9001:2015
EM ISO/IEC 17050:2010 (CE Mark)
2014/30/EU and 2011/65/EU
EN61326-1:2013 and EN55022/CISPR 22

3.2 COMPONENTS

The TEROS 12 sensor measures soil moisture, temperature, and EC of soil using stainless steel needles (Figure 4). TEROS 12 sensors measure soil moisture between Needle 1 and Needle 2 and EC between Needle 2 and Needle 3. Temperature is measured with an embedded thermistor in Needle 2. These sensors have a low power requirement, which makes them ideal for permanent burial in the soil and continuous reading with a data logger or periodic reading with a handheld reader.

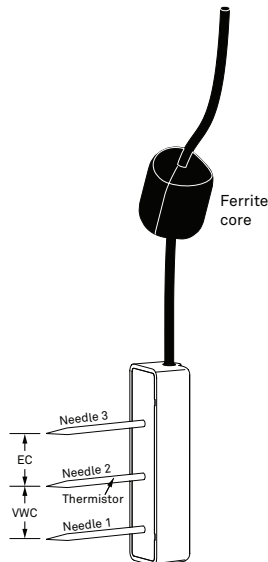

Figure 4 TEROS 12 sensor

SYSTEM

A ferrite core positioned on the TEROS 12 sensor cable 7.6 cm (3 in) away from the sensor head is utilized to isolate the sensor from any interferences in the system. This mitigates any potential noise from the system on the measured sensor data. It is important to not attach anything to the section of cable between the sensor head and the ferrite core as this may influence the measurements.

The TEROS 12 VWC measurement sensitivity is contained within a 1,010 mL volume roughly depicted in [Figure 5](#). Please see the application note [Measurement volume of METER volumetric water content sensors](https://www.metergroup.com/environment/articles/measurement-volume-meter-volumetric-water-content-sensors) (<https://www.metergroup.com/environment/articles/measurement-volume-meter-volumetric-water-content-sensors>) for testing protocol and more thorough analysis.

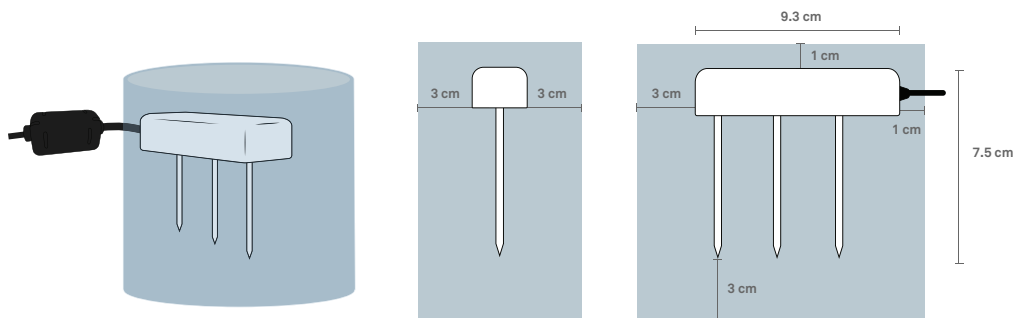

Figure 5 VWC volume of influence

NOTE: The TEROS 12 provides instantaneous or near-instantaneous measurements; however, because of the sensitivity of the measurement of the sensor head, the TEROS 12 is not well suited for spot measurements of VWC.

3.3 THEORY

The following sections explain the theory of VWC, temperature, and EC measured by TEROS 12.

3.3.1 VOLUMETRIC WATER CONTENT

TEROS 12 sensors use an electromagnetic field to measure the dielectric permittivity of the surrounding medium. The sensor supplies a 70-MHz oscillating wave to the sensor needles, which charge according to the dielectric of the material. The charge time is proportional to substrate dielectric and substrate VWC. The TEROS 12 microprocessor measures the charge time and outputs a raw value based on the substrate dielectric permittivity. The raw value is then converted to VWC by a calibration equation specific to the substrate ([Section 4.1](#)).

3.3.2 TEMPERATURE

The TEROS 12 uses a thermistor in the center needle to take temperature readings. This is more important for measurements near the surface where temperature changes are faster. The TEROS 12 sensor output temperature is in degrees Celsius unless otherwise stated in the data logger program, such as in preferences in the ZENTRA software.

NOTE: Even though the sensor head is white, in direct sunlight, the temperature measurement may read high. Use caution when installing the sensor with the sensor head in the sun.

3.3.3 ELECTRICAL CONDUCTIVITY

EC is the ability of a substance to conduct electricity and can be used to infer the amount of ions that are present in solution. EC is measured by applying an alternating electrical current to two electrodes and measuring the resistance between them. Bulk EC is derived by multiplying the inverse of the resistance (conductance) by the cell constant (the ratio of the distance between the electrodes to their area). TEROS 12 sensor bulk EC measurements are normalized to EC at 25 °C. The bulk EC measurement is factory calibrated to be accurate within $\pm 3\%$ of measurement from 0 to 20 dS/m. This range is adequate for most soil and growth substrate applications.

EC measurements above 10 dS/m are sensitive to contamination of the electrodes by skin oils, etc. Be sure to read [Section 4.2](#) about sensor cleaning if measuring the EC of salty soils.

3.3.4 CONVERTING BULK EC TO PORE EC

For many applications, it is advantageous to know the EC of the solution contained in the soil pores (σ_p), which is a good indicator of the solute concentration in the soil. Traditionally, σ_p is obtained by extracting pore water from the soil and measuring σ_p directly, a time-consuming and labor-intensive process. The TEROS 12 sensor measures the EC of the bulk soil surrounding the sensors (σ_b). A considerable amount of research has been conducted to determine the relationship between σ_b and σ_p . Hilhorst (2000) took advantage of the linear relationship between the soil bulk dielectric permittivity (ϵ_b) and σ_b to accurately convert σ_b to σ_p if the ϵ_b is known. The TEROS 12 sensor measures ϵ_b and σ_b nearly simultaneously in the same soil volume. Therefore, the TEROS 12 is well-suited to this method.

The pore water conductivity (σ_p) is determined from [Equation 1](#) (see Hilhorst 2000 for derivation):

$$\sigma_p = \frac{\varepsilon_p \sigma_p}{\varepsilon_b - \varepsilon_{ob=0}} \quad \text{Equation 1}$$

where

- σ_p is the pore water EC (dS/m),
- ε_p is the real portion of the dielectric permittivity of the soil pore water (unitless),
- σ_b is the bulk EC (dS/m) measured directly by the TEROS 12,
- ε_b is the real portion of the dielectric permittivity of the bulk soil (unitless), and
- $\varepsilon_{ob=0}$ is the real portion of the dielectric permittivity of the soil when bulk EC is 0 (unitless).

Dielectric permittivity of the soil pore water (ε_p) is calculated from soil temperature using [Equation 2](#):

$$\varepsilon_p = 80.3 - 0.37 \times (T_{soil} - 20) \quad \text{Equation 2}$$

where T_{soil} is the soil temperature (°C) measured by the TEROS 12.

Finally, $\varepsilon_{ob=0}$ is an offset term loosely representing the dielectric permittivity of the dry soil. Hilhorst (2000) recommended that $\varepsilon_{ob=0} = 4.1$ be used as a generic offset. Hilhorst (2000) offers a simple and easy method for determining $\varepsilon_{ob=0}$ for individual soil types, which improves the accuracy of the calculation of σ_p in most cases.

METER testing indicates that the method for calculating σ_p ([Equation 1](#)) results in good accuracy ($\pm 20\%$) in moist soils and other growth media. In dry soils, where VWC is less than about $0.10 \text{ m}^3/\text{m}^3$, the denominator of [Equation 1](#) becomes very small, leading to large potential errors. METER recommends that σ_p not be calculated in soils with $\text{VWC} < 0.10 \text{ m}^3/\text{m}^3$ using this method.

3.3.5 PORE WATER VERSUS SATURATION EXTRACT EC

As noted in [Section 3.3.4](#), pore water EC can be calculated from bulk EC using the sensor-measured dielectric permittivity of the medium. However, pore water EC is not the same as saturation extract EC.

Pore water EC is the EC of the water in the pore space of the soil. This could be measured directly if the soil was squeezed under high pressure to force water out of the soil matrix and that water was collected and tested for EC.

Saturation extract EC is the EC of pore water removed from a saturated paste. Saturation extract EC can be measured directly if distilled water is used to wet the soil until the soil saturates. The soil is then placed on filter paper in a vacuum funnel and suction is applied. An EC measurement on the water extracted from the saturated sample will give the saturation extract EC.

Theoretically, the pore water EC and saturation extract EC are related by the degree of saturation (VWC/total porosity) of the soil.

An example calculation illustrates this relationship:

Example A soil is at 0.1 m³/m³ VWC, has a pore water EC of 0.7 dS/m, and a dry bulk density of 1.5 Mg/m³

The total porosity of the soil can be calculated using [Equation 3](#):

$$\begin{aligned}\phi &= \frac{\rho_b}{\rho_s} \\ &= 1 - \frac{1.5}{2.65} \\ &= 0.43\end{aligned}\quad \text{Equation 3}$$

The saturation extract EC can be calculated as illustrated in [Equation 4](#):

$$\begin{aligned}\text{Solution EC} &= \frac{\sigma_p \Theta + \sigma_d (\phi - \Theta)}{\phi} \\ &= \frac{0.7(0.7 + 0)}{0.43} \\ &= 0.162 \text{ dS/m}\end{aligned}\quad \text{Equation 4}$$

where

- ϕ is the porosity,
- ρ_b is soil dry bulk density,
- ρ_s is density of the minerals (assumed to be 2.65 Mg/m³),
- σ_d is the EC of distilled water (0 dS/m), and
- Θ is VWC.

In practice, solution EC calculated from this method and solution EC taken from a laboratory soil test may not agree well because wetting soil to a saturated paste is very imprecise.

4. SERVICE

This section contains calibration information, calibration frequencies, cleaning guidelines, troubleshooting guidelines, customer support contact information, and terms and conditions.

4.1 CALIBRATIONS

Following is a list of the mineral soil, soilless media, and dielectric calibrations for TEROS 12, where Θ is the VWC (in m^3/m^3), where ε is dielectric, and where RAW is the raw sensor output, when read with a METER or third-party data logger.

The TEROS 12 is not sensitive to variation in soil texture and EC because it runs at a high measurement frequency. Therefore, its generic calibration equation should result in reasonable absolute accuracy; 0.03 m^3/m^3 for most mineral soils up to 8 dS/m saturation extract. Its calibration equations are shown below for mineral soil, soilless growing media (i.e., potting soil, perlite, or peat moss), and dielectric permittivity. However, for added accuracy, customers are encouraged to perform [soil-specific calibrations](#). For more information on how to calibrate sensors or to learn about METER calibration service (calibrations performed for a standard fee), see [soil sensor calibration](#) or contact [Customer Support](#).

4.1.1 MINERAL SOILS

According to METER tests, a single calibration equation will generally suffice for most mineral soil types with ECs from 0 dS/m to 8 dS/m saturation extract. VWC (Θ) is given by [Equation 5](#):

$$\Theta\left(\text{m}^3 / \text{m}^3\right) = 3.879 \times 10^{-4} \times RAW - 0.6956 \quad \text{Equation 5}$$

A linear equation is used for the mineral soil calibration because it provides the best predictions of VWC in the range of VWC found in mineral soils, but this equation reaches a maximum at approximately 0.70 m^3/m^3 in pure water. To display data on a scale from 0 to 1.0 m^3/m^3 , VWC should be modeled with a quadratic equation (which would result in a 1.0 m^3/m^3 in water). However, METER does not recommend this for mineral soils because it often makes the calibration in the range of VWC found in mineral soil less accurate.

4.1.2 SOILLESS MEDIA

TEROS 12 sensors are calibrated in potting soil, perlite, and peat. The goal is to create a generic calibration equation that will work in many nonsoil substrates with an accuracy of better than 0.05 m^3/m^3 . For higher accuracy, performing a media-specific calibration should improve the accuracy to 0.01 to 0.02 m^3/m^3 . The differences between mineral soil and soilless media calibrations are caused by high-air volume in the organic soils that lowers the starting (dry media) dielectric of the sensor.

The calibration for several potting soils, perlite, and peat moss is shown in [Equation 6](#):

$$\theta(\text{m}^3/\text{m}^3) = 6.771 \times 10^{-10} \times RAW^3 - 5.105 \times 10^{-6} \times RAW^2 + 1.302 \times 10^{-2} \times RAW - 10.848 \quad \text{Equation 6}$$

4.1.3 APPARENT DIELECTRIC PERMITTIVITY

Apparent dielectric permittivity (ϵ_a) can be used to determine VWC using external published equations such as the Topp equation (Topp et al. 1980). Dielectric permittivity is also used for calculating pore water EC. Dielectric permittivity is given by [Equation 7](#):

$$\epsilon = 1.112 \times 10^{-18} \times RAW^{5.607} \quad \text{Equation 7}$$

4.2 CLEANING

If the sensor needles become contaminated with oils from contact with skin or another source, it is necessary to clean the needles to ensure accurate EC readings in salty soils with bulk EC greater than 10 dS/m.

1. Clean each needle using a mild detergent such as liquid dish soap and a nonabrasive sponge or cloth.

NOTE: Avoid detergents that contain lotions or moisturizers.

2. Rinse the sensor and needles thoroughly with tap or deionized (DI) water.

NOTE: Do not touch the needles with an ungloved hand or bring them in contact with any source of oil or other nonconducting residue.

4.3 TROUBLESHOOTING

Table 3 Troubleshooting the TEROS 12

Problem	Possible Solution
Sensor not responding	Check power to the sensor.
	Check sensor cable and 3.5-mm plug connector integrity. Check data logger wiring to ensure brown is power supply, orange is digital out, and bare is ground.
Sensor reading too low (or slightly negative)	Check for air gaps around sensor needles. These could be produced below the surface of the substrate when the needle contacts a large piece of material and pushes it out of the way, or if the sensor is not inserted perfectly linearly.
	Ensure the calibration equation being used is appropriate for the media type. There are significant differences between substrate calibrations, so be sure to use the one specific to the substrate.

Table 3 Troubleshooting the TEROS 12 (continued)

Problem	Possible Solution
Sensor reading too high	<p>Check to make sure that the media was not packed excessively or insufficiently during sensor installation. Higher density can cause sensor reading to be elevated.</p> <p>Ensure the calibration equation being used is appropriate for the media type. There are significant differences between calibrations, so be sure to use the one most suitable to the substrate, or consider developing a substrate-specific calibration for the particular medium.</p> <p>Some substrates have an inherently high dielectric permittivity (soils of volcanic origin or high titanium, for instance). If the substrate has a dry dielectric permittivity above 6, a custom calibration may need to be performed. Soils with a bulk EC greater than 10 dS/m require substrate specific calibrations (Section 4.1).</p>
Cable or stereo plug connector failure	<p>If a stereo plug connector is damaged or needs to be replaced contact Customer Support for a replacement connector and splice kit.</p> <p>If a cable is damaged follow these guidelines for wire splicing and sealing techniques.</p>

4.4 CUSTOMER SUPPORT

Customer service representatives are available for questions, problems, or feedback Monday through Friday, 7 am–5 pm Pacific time.

Email: support.environment@metergroup.com
sales.environment@metergroup.com

Phone: +1.509.332.5600

Fax: +1.509.332.5158

Website: metergroup.com

If contacting METER by email, please include the following information:

Name	Email address
Address	Instrument serial number
Phone	Description of the problem

NOTE: For TEROS 12 sensors purchased through a distributor, please contact the distributor directly for assistance.

4.5 TERMS AND CONDITIONS

By using METER instruments and documentation, you agree to abide by the METER Group, Inc. USA Terms and Conditions. Please refer to www.metergroup.com/company/meter-group-inc-usa-terms-conditions for details.

REFERENCES

Hilhorst MA. 2000. A pore water conductivity sensor. *Soil Science Society of America Journal* 64:6 1922–1925.

Topp GC, David JL, and Annan AP. 1980. Electromagnetic determination of soil water content: Measurement in coaxial transmission lines. *Water Resources Research* 16(3): 574–582.

INDEX

- A**
- applications 1
- C**
- calibration 18–19
 - custom soils calibration 18
 - mineral soils 18
 - soilless media 18
 - cleaning the sensors 15, 19
 - compliance 13
 - CE 13
 - declaration of conformity 13
 - components 13–14
 - cable 11
 - connector types 11
 - ferrite core 14
 - needles 11, 13
 - thermistor 13
 - configuration
 - See data loggers, connect to METER logger
 - customer support 20
- D**
- data loggers 7–8, 11
 - connect to METER logger 7
 - connect to non-METER logger 8–9
- E**
- electrical conductivity 15–17
 - bulk electrical conductivity 15
 - pore water electrical conductivity 15–16
 - saturation extract electrical conductivity 16–17
- F**
- ferrite core
 - about 14
 - installation 3
- I**
- installation
 - ferrite core 3
 - installation tool 2
 - methods 6–7
 - borehole 6
 - trench 6
 - orientation 4
 - preparation 3
 - tools needed 2
- M**
- maintenance
 - See cleaning the sensors
- R**
- references 22
- S**
- safety 2
 - soil moisture 13
 - specifications 10–13
 - data logger compatibility 11
 - dielectric measurement frequency 10
 - EC
 - See specifications, electrical
 - conductivity
 - electrical and timing characteristics 11–13
 - electrical conductivity 10
 - output 10
 - physical specifications 11
 - temperature 10
 - volume of influence 14
 - volumetric water content 10
 - VWC
 - See specifications, volumetric water content

T

- temperature
 - theory 15
- terms and conditions 21–22
- theory 14–17
 - electrical conductivity 15–17
 - See also electrical conductivity
 - temperature 15
 - volumetric water content 14
- VWC
 - See theory, volumetric water content
- troubleshooting 19–20

V

- volumetric water content
 - specifications 10
 - theory 14

METER Group, Inc. USA
2365 NE Hopkins Court
Pullman, WA 99163
T: +1.509-332-5600 F: +1.509.332.5158
E: info@metergroup.com
W: www.metergroup.com

