

INSTRUCTION MANUAL

Pyrheliometer

MS-56

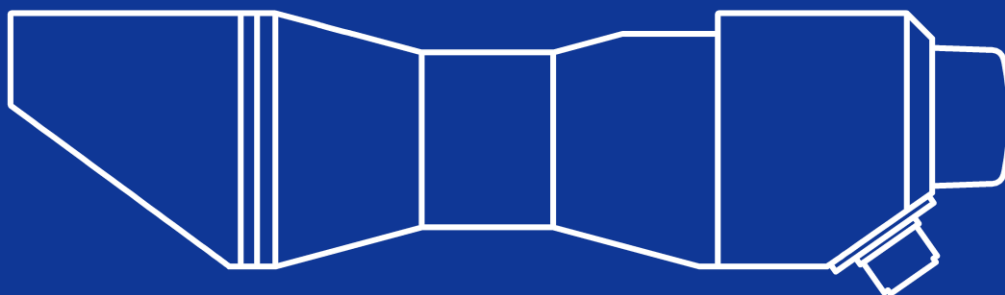

EKO

1. Index

1. Index	1
2. Important User Information	2
2-1. Contact Information	2
2-2. Warranty and Liability	2
2-3. About Operating Manual	3
2-4. Environment	3
2-5. CE Declaration	4
3. Safety Information	5
3-1. General Warnings	5
4. Introduction	6
4-1. Introduction	6
4-2. Content of Delivery	7
5. Getting Started	8
5-1. Parts Descriptions	8
5-2. Setup	9
5-3. Operation	14
6. Maintenance & Troubleshooting	15
6-1. Maintenance	15
6-2. Calibration and Measurement Uncertainty	17
6-3. Troubleshooting	18
7. Specification	19
7-1. Specifications	19
7-2. Specification Definitions	20
7-3. Product Accessories	22
APPENDIX	23
A-1. Symbols	23
A-2. Thermistor Temperature Conversion Table	24
A-3. Pt100 Class A Conversion Table	25

2. Important User Information

Thank you for using EKO Products.

Reading this manual is recommended prior to installation and operation of the product. Keep this manual in safe and handy place for whenever it is needed.

For any questions, please contact us at below:

2-1. Contact Information

EKO INSTRUMENTS CO., LTD.

Asia, Oceania Region

www.eko.co.jp	EKO INSTRUMENTS Co., Ltd.	
info@eko.co.jp	1-21-8 Hatagaya, Shibuya-ku	Tel: +81 (3) 3469-6711
	Tokyo, 151-0072 Japan	Fax: +81 (3) 3469-6719

Europe, Middle East, Africa, South America Region

www.eko-eu.com	EKO INSTRUMENTS Europe B.V.	
info@eko-eu.com	Lulofsstraat 55, Unit 32,	Tel: +31 (0)70 3050117
	2521 AL, Den Haag, The Netherlands	Fax: +31 (0)70 3840607

North America Region

www.eko-usa.com	EKO INSTRUMENTS USA Inc.	
info@eko-usa.com	95 South Market Street, Suite 300	Tel: +1 408-977-7751
	San Jose, CA 95113 USA	Fax: +1 408-977-7741

2-2. Warranty and Liability

For warranty terms and conditions, please contact EKO Instruments or your distributor for further details.

EKO guarantees that the product delivered to customer has been tested to ensure the instrument meets its published specifications. The warranty included in the conditions of delivery is valid only if the product has been installed and used according to the instructions provided in this operating manual.

In case any manufacturing defect(s) will occur, the defected part(s) will be repaired or replaced under warranty; however the warranty will not be applicable if:

- Any modification or repair has been done by other than EKO service personnel.
- The damage or defect is caused by disrespecting the specifications mentioned on the product brochure or instruction manual.

2-3. About Operating Manual

Copy Rights Reserved by EKO INSTRUMENTS CO., LTD. Making copies of whole or part of this document without permission from EKO is prohibited.

This manual was issued: 2016/10/06

Version Number: 5

2-4. Environment

1. WEEE Directive 2002/96/EC (Waste Electrical and Electronic Equipment)

This product is not subjected to WEEE Directive 2002/96/EC however it should not be mixed with general household waste. For proper treatment, recovery and recycling, please take this product(s) to designated collection points.

Disposing of this product correctly will help save valuable resources and prevent any potential negative effects on human health and the environment, which could otherwise arise from inappropriate waste handling.

2. RoHS Directive 2002/95/EC

EKO Instruments has completed a comprehensive evaluation of its product range to ensure compliance with RoHS Directive 2002/95/EC regarding maximum concentration values for substances. As a result all products are manufactured using raw materials that do not contain any of the restricted substances referred to in the RoHS Directive 2002/95/EC at concentration levels in excess of those permitted under the RoHS Directive 2002/95/EC, or up to levels allowed in excess of these concentrations by the Annex to the RoHS Directive 2002/95/EC.

2-5. CE Declaration



IMPORTANT USER INFORMATION



DECLARATION OF CONFORMITY

We: EKO INSTRUMENTS CO., LTD
1-21-8 Hatagaya, Shibuya-ku
Tokyo, 151-0072 JAPAN

Declare under our sole responsibility that the product:

Product Name: Pyrheliometer
Model No.: MS-56

To which this declaration relates is in conformity with the following harmonized standards of other normative documents:

Harmonized standards:

EN 61326-1:2006 Class A (Emission)
EN 61326-1:2006 (Immunity)
EN 61000-4-2 EN 61000-4-3
EN 61000-4-4 EN 61000-4-5
EN 61000-4-6 EN 61000-4-8
EN 61000-4-11

Following the provisions of the directive:

EMC-directive: 89/336/EEC
Amendment to the above directive: 93/68/EEC

Date: April 28, 2011

Position of Authorized Signatory: Deputy General Manager of Quality Assurance Dept.

Name of Authorized Signatory: Shuji Yoshida

Signature of Authorized Signatory: *Shuji Yoshida*

3. Safety Information

EKO Products are designed and manufactured with consideration for safety; however, please make sure to read and understand this instruction manual thoroughly to be able to operate the instrument safely in the correct manner.



**WARNING
CAUTION**

Attention to user; pay attention to the instructions given on the instruction manual with this sign.



3-1. General Warnings

Setup

When applying the window heating the power consumption at 12 VDC is approximately 0.5 W. Check your DC output Voltage before operating, higher voltages will lead to permanent damage of the heater.

4. Introduction

4-1. Introduction

The ISO9060 First Class MS-56 is a research grade normal incidence direct solar irradiance sensor also known as a pyrhelimeter or DNI sensor which highly suitable for routine operation on automated Sun Tracker. The all-weather MS-56 is sensitive to solar irradiance throughout the spectral range 200 to 4,000nm and can work under most extreme conditions in a temperature range from -40°C to +80°C.

In principle to perform high precision direct solar radiation measurements under non-stable atmospheric conditions, ideally a fast responding detector is required to detect quick radiation changes. Although photodiode type detector offer a quick response but it has a limited spectral sensitive range; in contrary thermopile broad band detectors cover the full spectral range, but it is considered to be slow. The versatile MS-56 combines all those features of a quick broadband detector enabled by an advanced technology thermopile detector. It combines a unique fast response time (<1s 95%), high sensitivity, excellent thermal stability and very low temperature coefficient to make it hardly immune to ambient temperature variations, therefore it is suitable to be used in a wide temperature range.

The MS-56 has a standard full 5° (degrees) opening angle and 1° slope angle as defined by ISO Pyrhemeters Standards and greatly performs when used in combination with the EKO STR-21(G) or STR-22(G) Sun Tracker. The standard built-in thermistor (44031, 10kΩ@25°C) or platinum resistance temperature sensor (Pt100, Class A, IEC751 compliance) can be used as a temperature reference for extensive research purposes. The integrated low power window heater prevents dew deposition or frost on the outside window.

The MS-56 has a robust but compact and smooth design which forms the new generation of EKO Instruments solar radiometers that are designed for most demanding Photovoltaic and Meteorological applications at any place on earth.

Each MS-56 is calibrated and tested at EKO upon manufacture against EKO's reference sensors which are fully traceable to the WRR (World Radiometric Reference) maintained at the PMOD/WRC (Physikalisch-Meteorologisches Observatorium Davos/World Radiation Center) in Davos, Switzerland.

4-2. Content of Delivery

Check the package contents first; if any missing item or damage is noticed, please contact EKO immediately.

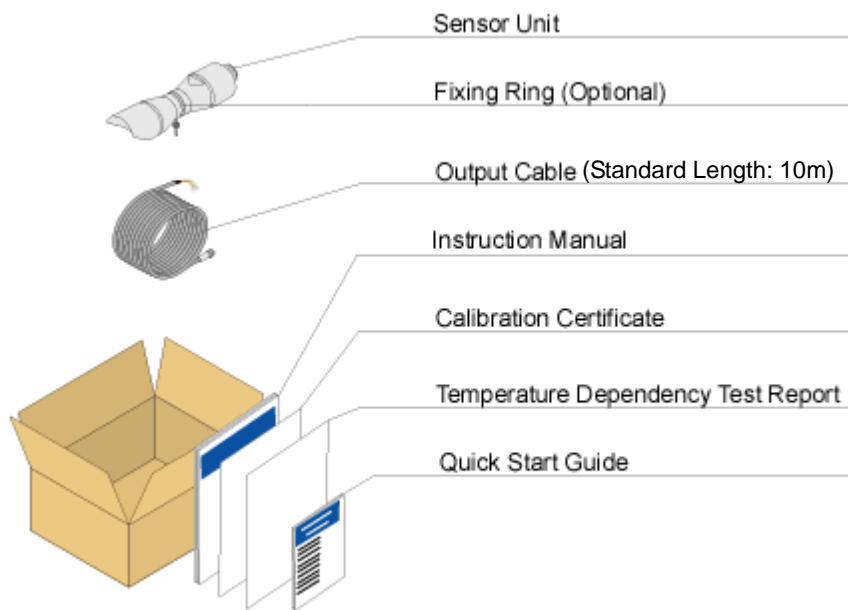

Figure 4-1. Package Contents

5. Getting Started

5-1. Parts Descriptions

MS-56 pyrheliometer is designed to capture direct solar radiation with high precision and long term reliability. The new concept is a result of combining new technologies with proven pyrheliometer basics to fulfill most stringent demands for solar energy research in the Photovoltaic and Meteorological market.

The Pyrheliometer is based on a well balanced light weight thermopile detector, which gives a highly stable output under most critical situations and variable measurement conditions. Each detector is individually characterized and temperature compensated to guarantee its best performance. During field operating, the detector temperature can be monitored with a thermistor (44301 10k Ω) or platinum resistance temperature sensor (Class A Pt100) to extend further research applications.

Although the MS-56 dimensions are relatively small, it has a full 5° opening angle and 1° slope angle geometry. The front aperture has a unique integrated alignment sight for easy and precise alignment of the instrument on a Sun Tracker. The removable rain cap can be used as a rain shield but can also be taken off when the measurement conditions allow. In order to attain the proper spectral characteristics and spectral range, the pyrheliometer has Quartz precision optics and ultra low reflective black detector absorber to capture direct solar radiation in the specified spectral range.

The large volume desiccant cartridge ensures a dry environment inside the pyrheliometer to protect delicate optical parts from any condensation. A cable with plug in connector is provided for easy handling and flexibility during installation, maintenance and service. The basic construction outline is shown in the assembly drawing.

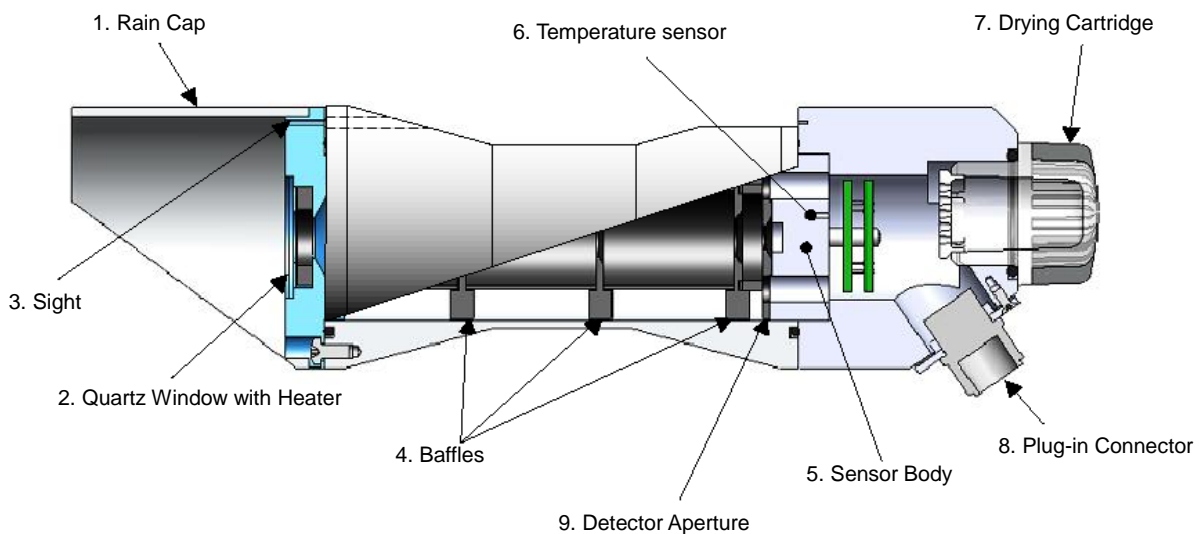
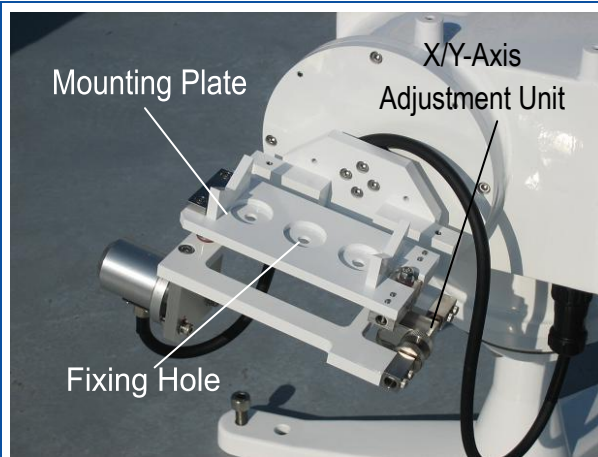

Figure 5-1. MS-56 Body

5-2. Setup

1. Installation

In this application the MS-56 is mounted on the EKO Sun Tracker STR-21G/22G, which is a fully automatic sun tracking system supporting solar sensors capable of measuring Direct, Diffuse and Global radiation.



- 1) When mounting the MS-56, use the fixing hole in the middle of the mounting plate.
*If the mounting plate is the 2-hole version, it is necessary to replace with 3-hole version. (See following [2. How to Replace Mounting Plate (Optional)])



- 2) Remove the knurling nut from the MS-56 mounting screw by hand. (Above picture shows condition the knurling nut is removed.)



- 3) Place the MS56 on the Sun Tracker mounting plate. Insert the mounting screw through the mounting plate center hole.



- 4) Attach the knurling nut which was removed earlier back on the mounting screw; tighten so the MS-56 is fixed securely.

2. How to Replace the Mounting Plate (Optional)

When installing MS-56 on EKO Sun Tracker STR-21G/22G, 3-hole mounting plate is required.

If you already have EKO Sun Tracker purchased before July 2011, you need to purchase the “3-hole mounting plate” (optional part) separately for installing MS-56.

If the 3-hole mounting plate is already installed, skip this section and go to [3. Electrical Connection].

[Prepare the following tool for installation]: One Allen Key 2.5 (for M3 screw).

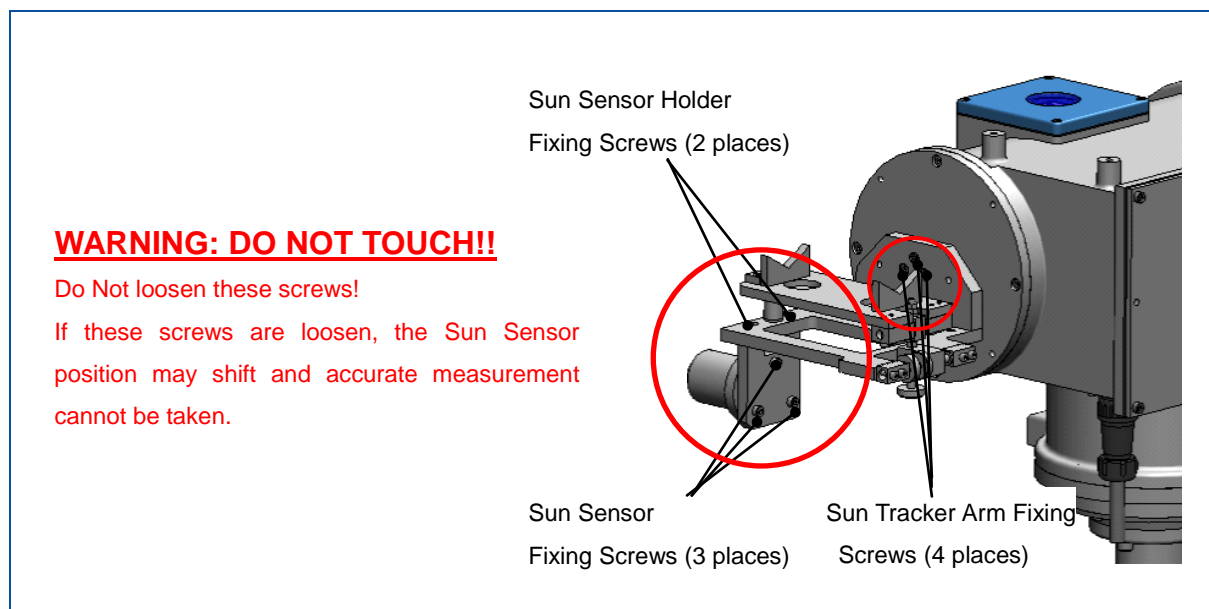

[How to Replace]

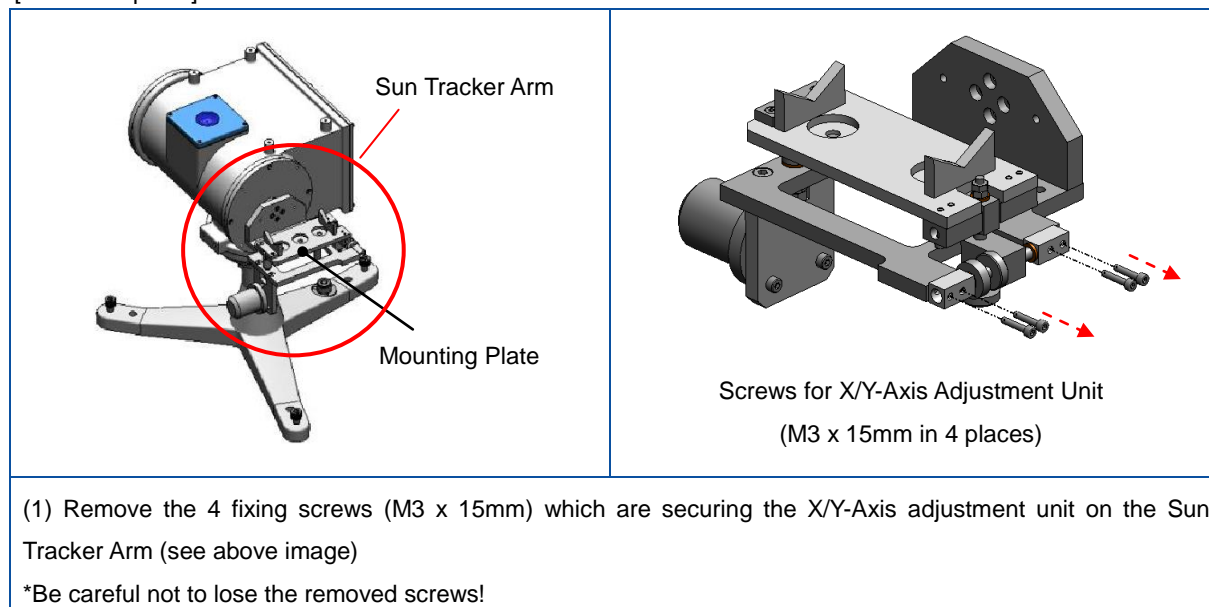

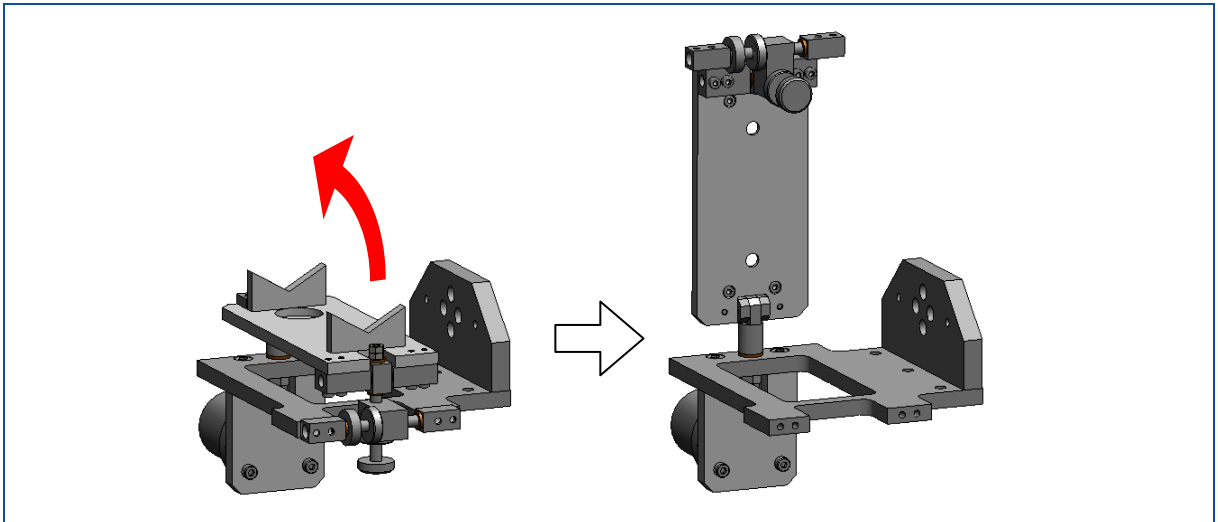

(2) Lift up the mounting plate as shown on the image above.

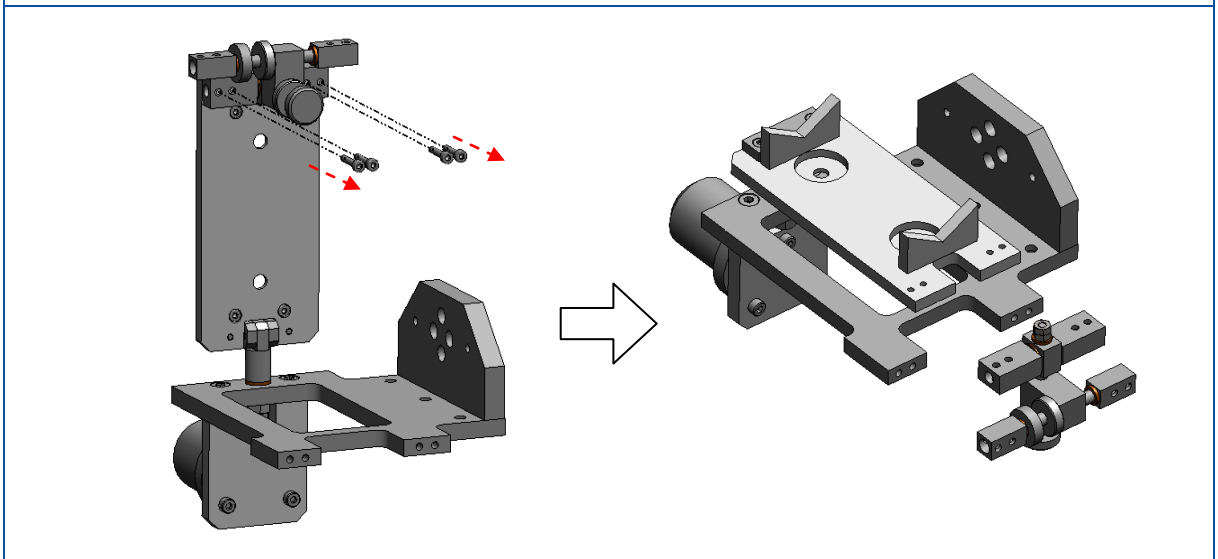

(3) As the mounting plate is lifted, remove another 4 fixing screws (M3 x 15mm) on X/Y-Axis adjustment unit then detach the X/Y-Axis adjustment unit from the mounting plate.

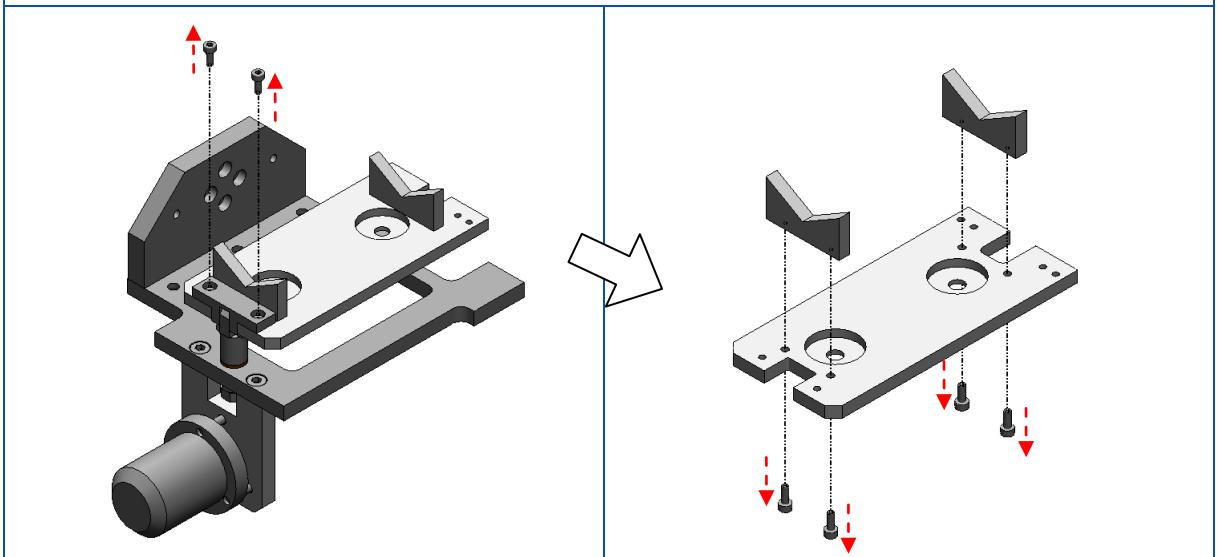

(4) Remove 2 fixing screws (M3 x 15mm) for mounting plate. Detach the mounting plate from the Sun Tracker Arm, and remove the fixing screws on both V-Blocks (M3 x 5mm in 2 places on each V-Block).

Disassembling is completed and the 2-hole mounting plate is replaced with 3-hole mounting plate.

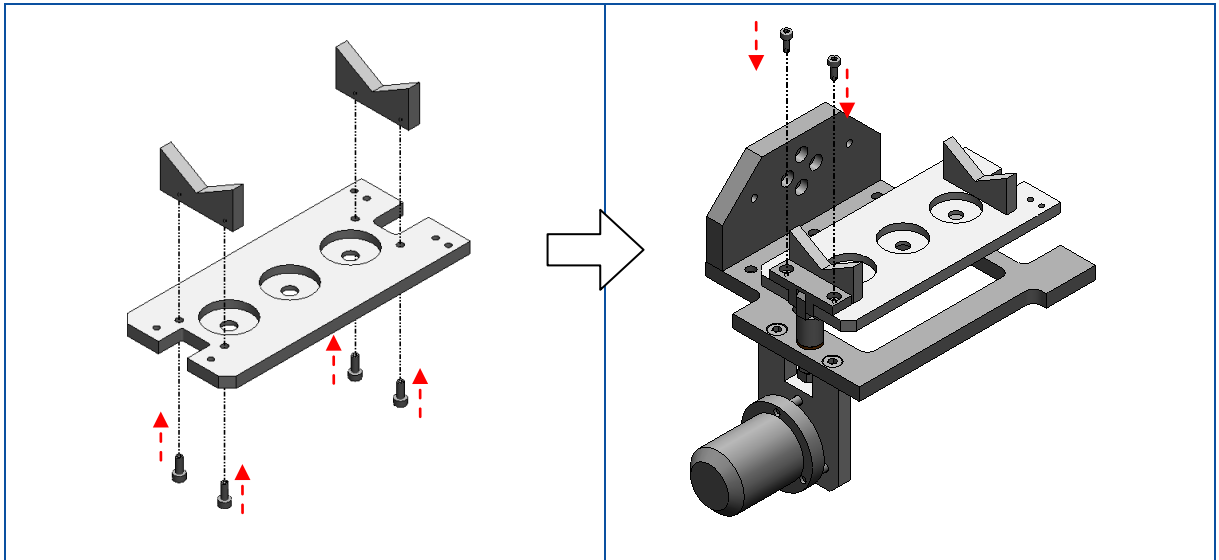

(5) Attach the V-Blocks on the 3-hole mounting plate with fixing screws (M3 x 5mm in 2 places for each V-Block) then attach the 3-hole mounting plate on the Sun Tracker Arm with 2 fixing screws. (M3 x 15mm)

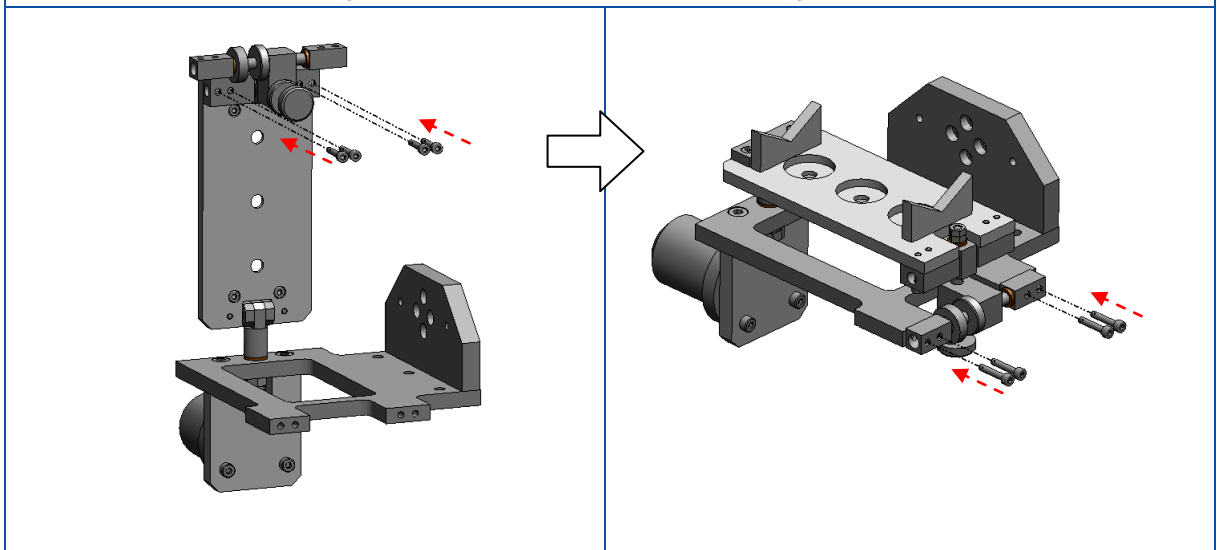

(6) Attach the X/Y-Axis adjustment unit on the 3-hole mounting plate with the fixing screws (M3 x 15mm in 4 places) then attach the X/Y-Axis adjustment unit on the Sun Tracker Arm with the fixing screws (M3 x 15mm in 4 places)

Check to make sure all the screws are placed back in their positions.

3. Electrical Connection

In order to measure the solar irradiance, the MS-56 should be connected to a measurement device, in most cases a data logger. MS-56 is a passive sensor that does not need any power; however to operate the window heater, a DC12V (0.5W) power supply is required for heating.

It is recommended to keep the cable length between data logger and the sensor as short as possible. Depending on how the cable is lined, unwanted noise is caused; thus, keep the cable away from the noise cause, such as AC cable or high voltage line. Also in some cases, more noise is seen depending on the type of data logger used.

Using a signal converter is recommended when the distance between the pyr heliometer is > 50m. Connect the cable connector to the MS-56 chassis plug and keep sufficient length to allow free rotation when installed on a Sun Tracker.

The wire color codes are shown in the table below.

Table 5-1 Wire Color Codes

	Color		Wires	
	Brown		Sensor output	+
	Red		Sensor output	-
	Yellow		Heater Input (12V DC)	+
	Green		Heater Input (12V DC)	-
	Blue		PT100 (A) 3-wire	
	Gray			
	White		PT100 (B) 3-wire or Thermistor (B)	
	Black		Thermistor (A)	
	Yellow / Green (Stripe Color)		Ground (Shield)	

Note:

The pyr heliometer housing is connected to the shielded cable (yellow stripe). When the shielded cable is connected to the data logger ground, the pyr heliometer should be electrically isolated from the sun-tracker system or the sun tracking system should not be connected to ground.

4. Sight Spot Adjustment

In order to take an accurate measurement, MS-56 has to be aligned with the sun properly. When the sky is clear, the sun light will go through the sight and a spot of light is shown on the sight spot surface of body top. Adjust the X/Y-Axis adjustment unit (Zenith and Azimuth angles) so the center of this light spot will hit the dot engraved on the sight spot surface.

When the MS-56 is installed on an automated sun tracking system, like the EKO Sun Tracker and taking a long-term measurement, check the sight spot on the next day after installation to make sure the spot is still in the place, and continue checking the sight spot periodically.

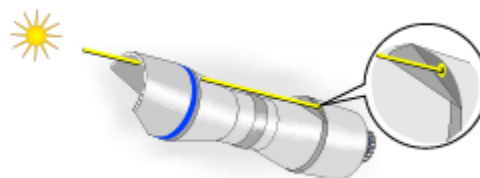

Figure 5-2 Sight Spot Adjustment

5-3. Operation

After installing and connecting MS-56 to the measurement device, MS-56 can be operated and is ready to collect solar radiation data.

It is recommended to use the window heater to prevent dew deposition at the Quartz window. Turn on the heater at least 30 minutes before sunrise. After sun rise, the window heater might be switched off to save energy.

1. Calculate Direct Normal Incidence Solar Irradiance

The direct normal incidence solar irradiance is calculated from the measured output voltage according to the following linear expression.

$$I = E/S$$

I	[W/m ²]:	Direct Normal Incidence solar irradiance
E	[μV]:	Output voltage of the sensor
S	[μV/W · m ⁻²]:	Sensitivity (Indicated on the calibration certificate)

2. Calculate Direct Horizontal Incidence Solar Irradiance

The direct horizontal incidence solar irradiance is calculated from the measured output voltage according to the following linear expression.

$$I_{hor.} = I \cdot \sin \theta$$

θ	[°]:	Solar Elevation Angle
----------	------	-----------------------

3. Calculate Detector Temperature

When a thermistor temperature sensor (44031 10kΩ) is used, the detector temperature T[°C] can be converted from resistance R[Ω] by using the following formula. The temperature conversion table is also shown in Appendix A-2.

[Thermistor (44031 10kΩ)]

$$T = (\alpha + \beta (\ln(R)) + \gamma (\ln(R))^3)^{-1} - 273.15$$

$$\alpha = 1.0295 \cdot 10^{-3}$$

$$\beta = 2.3910 \cdot 10^{-4}$$

$$\gamma = 1.5680 \cdot 10^{-7}$$

When using a platinum resistance temperature sensor (Pt100, Class A), see the temperature conversion table shown in Appendix A-3.

6. Maintenance & Troubleshooting

6-1. Maintenance

Once the MS-56 is installed, it is essentially free of any maintenance although care must be taken to keep the instrument in the best condition for accurate measurement.

1. Data Verification

By analyzing the measurement data (such as irradiance and temperature), user can verify the condition of the instrument. When abnormal data is found, either the sight of the pyrhelimeter is not aligned or the instrument has some defect. Check the condition of cable at the same time checking on the pyrhelimeter setup condition.

2. Cleaning of Quartz Window

Clean the quartz window with a soft cotton cloth and alcohol or demineralized water when it gets soiled. Since soiling will have an effect on the performance of the radiometer by means of reduced optical transmission of the solar radiation and consequently leads to a reduced detector output. Despite no proper indication can be given on the required cleaning interval since it is strongly depending on the local environmental conditions affected by Rain, Snow, Ice, Dust, Sand, or Salt. Environmental factors like frequent rain fall can also have a positive effect on cleaning by washing off any sand or dust particles. For specific cases it might be an advantage to remove the Rain Cap and benefit from this effect. The success of this approach can be determined empirically.

3. Desiccant Inspection

Periodically the desiccants need to be exchanged to maintain a dry environment inside the pyrhelimeter. The frequency of replacement varies with the operating conditions on location but annual replacement is recommended. The section at the next page shows how to replace desiccant.

4. Pyrhelimeter Alignment

The measurement performance can also be inspected by carefully analyzing the measurement data (e.g. irradiance and temperature). Any abnormality found in the data might be caused by misalignment of the sensor or defect. At regular intervals, the quality of the cables can be checked like the alignment of the pyrhelimeter.

5. Clean the Sight

Sometimes rain and dirt maybe collected in the through-hole for the sight and the sight spot cannot be confirmed. Clean and remove the water and/or dirt by using a small diameter pin.



6. Recalibration

EKO Instruments recommend to recalibrate the sensor every 2 years.

Table 6-1 Maintenance check List

Check List	Action
Data verification	Check the wiring connections
Cleaning of Quartz window	Use soft cotton cloth and alcohol or demineralized water
Desiccant inspection	Change in case the silica gel color turned from blue to reddish color
Pyrheliometer alignment	Check sights for alignment. When the sight spot cannot be confirmed, clean the through-hole with a pin to remove the water and/or dirt.
Recalibration	Every 2 years

[How to Replace Desiccant]

	
<p>1) Turn the drying cartridge in anti-clockwise. No tools are required.</p>	<p>2) The drying cartridge can be removed easily by hand.</p>
	
<p>3) Take off the inner lid.</p>	<p>4) Exchange the desiccant then put the inner lid back on the cartridge. Place the drying cartridge back on the MS-56 body and secure it gently.</p>

6-2. Calibration and Measurement Uncertainty

It is recommended to recalibrate the instrument once every 2 years. For further information about the calibration and recalibration, please contact EKO.

1. Calibration Method

The MS-56 is calibrated under natural sun light against the EKO instruments reference pyrheliometer which is traceable to the World Radiation Reference (WRR) maintained at the World Radiation Center (PMOD) in Davos (CH).

Both MS-56 and reference pyrheliometer are mounted on a Sun Tracker to capture the direct solar radiation. The direct solar radiation is measured based on 1 minute samplings for total of more than 2 hours both in the morning and the afternoon on a clear day. The calibration value of the subjected pyrheliometer was obtained by multiplying the sensitivity value [$\mu\text{V}/\text{W}\cdot\text{m}^{-2}$] of the reference pyrheliometer with the averaged ratio of the measured total direct irradiance data. To improve the calibration accuracy and minimize the measurement uncertainty several operating criteria are applied.

2. Calibration Uncertainty and Traceability

The criteria for the operating conditions like the indicated ambient temperature, minimum direct radiation and minimum solar elevation angle are applied to minimize the overall uncertainty in the calibration. The pyrheliometer uncertainty figure is statistically calculated based on a standard deviation of (1.96σ) , which means that 95% of the measured direct irradiance values agree with the reference pyrheliometer.

The reference pyrheliometer will be calibrated at ATLAS/DSET every 2 years against a primary standard pyrheliometer, called absolute cavity pyrheliometer. The ATLAS/DSET absolute radiometer is directly traceable to the WRR (World Radiometric Reference) and maintained in the group of standard radiometers calibrated every 5 years during the IPC (International Pyrheliometer Comparison), as well as by NPC (NREL Pyrheliometer Comparison) which is held every year.

The data acquisition system is traceable to JEMIC (Japan Electric Meters Inspection Corporation).

6-3. Troubleshooting

This section contains information that can be used to make a failure diagnosis whenever the sensor does not function properly. Contact your distributor or EKO for any further technical support.

Table 6-3 Troubleshooting

Potential failure	Action
The sensor does not give any signal output	<ol style="list-style-type: none">1. Measure the impedance across the sensor output wires. This sensor resistance should lie in the specified range (see 7.1 Specifications). If it is close to zero Ohms there is a short circuit (check the wiring). If it is infinite, there is a broken contact (check the wiring).2. If no problem found from the above, check the output with another measurement device to make sure the actual data logger or measurement device is functioning properly.
The sensor signal is unrealistically high or low.	<ol style="list-style-type: none">1. Check if the correct sensitivity is applied to the algorithm (see 5-3. Operation). Please note that each sensor has its own individual sensitivity. Check if the voltage reading is divided by the correct sensitivity value.2. Check the sight spot and make sure the MS-56 is aligned to the direction of the sun.
The sensor signal shows unexpected variations.	<p>Although the sensor is hardly susceptible to Electro Magnetic Interference (IME), it may pick up noise depending on the measuring environment.</p> <ol style="list-style-type: none">1. Check the presence of strong EM sources of radar, radio, etc..2. Check the grounding condition (shielding). Check the condition of the sensor cable.

7. Specification

7-1. Specifications

Table 7-1 Specification: Specifications are indicated as typical values.

Specification	MS-56	ISO 9060 First Class	WMO Good Quality
Response time (95%)	< 1 s	< 20s	< 30s
Non-Linearity (100 – 1000 W/m ²)	< +/- 0.5 %	< +/-0.5%	< +/- 0.5 %
Zero Offset (response to 5 K/h change in ambient temperature)	< +/- 1 W/m ²	< +/- 3 W/m ²	< 4 W/m ²
Spectral Selectivity (350 to 1500 nm ^{ISO} /3000 nm ^{WMO})	< +/- 1 %	< +/- 1 %	1 %
Tilt response	< +/- 0.2 %	< +/- 0.5 %	0.5 %
Temperature Dependency (-20 to + 50°C / @ 20°C)	< +/- 0.5 %	< +/- 2 % (For 50°C band)	< 2% (For 50°C band)
Non Stability (Change per year)	< +/- 0.5 %	< +/- 1 %	< +/- 0.5 %
Expected Daily Uncertainty	< +/- 1 %	---	< +/- 1 %
Irradiance Range	0 –2000W/m ²	---	---
Spectral Range (FWHM)	200 –4000nm	---	---
Sensitivity	Approx.10μV/W · m ⁻²	---	---
Detector Impedance @ 25°C	Approx.5 kOhms	---	---
Operating Temperature	-40 to +80 °C	---	---
Ingress Protection Rating	IP 67	---	---
Low Voltage Regulations	IEC 61326-1-2006	---	---
Compliance	CE Compliant	---	---
Outer Dimensions (Length x Diameter)	217mm x 55mm	---	---
Cable Length (Standard)	10 m	---	---
Weight (Including 10m cable)	0.6kg (1.6 kg)	---	---
Heater power for optional window heater to prevent dew deposition	DC12V / 0.5W	---	---
Calibration Traceability (ISO 9847)	WRR	---	---
Recommended Recalibration Interval	Every 2 years	---	---
Sensor for Temperature Measurement (Internal Temperature Measurement)	- Pt100 Class A, IEC751 Compliance - Thermister 44031, 10kΩ@25°C	---	---

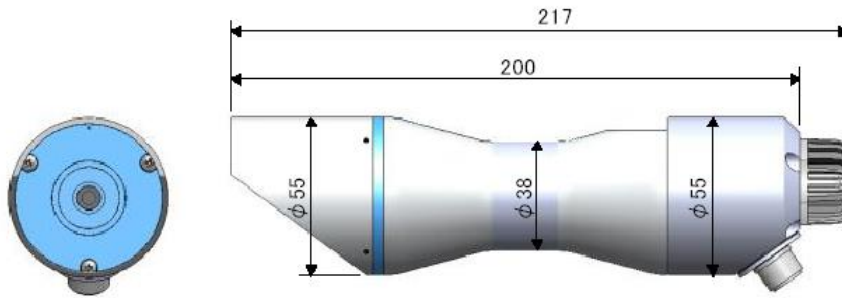

Figure 7-1. MS-56 Outer Dimensions

7-2. Specification Definitions

1. Response Time (Typical)

A response time of less than 1s to achieve 95% of the final measurement value is one of the unique features of the MS-56. The small thermopile detector having a low heat capacitance and high thermal conductivity responds quickly to changes of the solar radiation. To keep the detector-output stable and in perfect thermal balance during changing environmental and solar radiation conditions, the detector body is isolated from the sensor housing. When using a data logger with a sampling frequency of 1second, because of the fast responding detector the measurement data are stored without losses of the natural radiation changes.

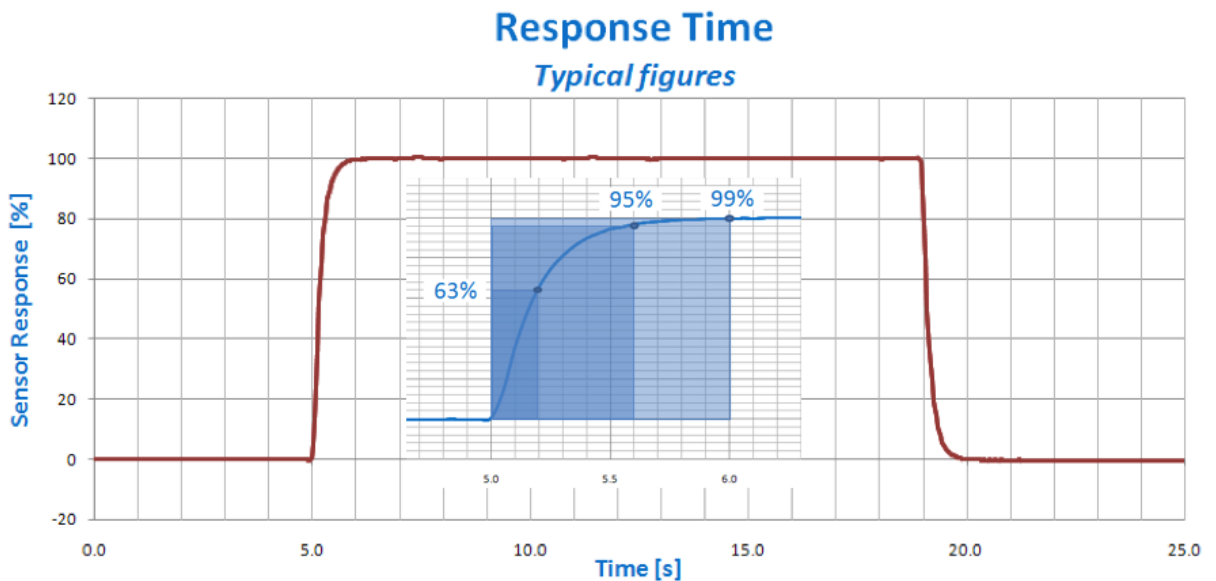

Figure 7-1. Response Time Measurement

2. Temperature Dependency (Typical)

In general the sensitivity of optical detectors depends on the temperature of the instrument because of material properties, known as the temperature coefficient (TC). However the MS-56 sensor construction has a built in special passive compensation network which reduces the temperature dependency to less than $\pm 0.5\%$ between -20°C and $+50^{\circ}\text{C}$. To achieve this low temperature dependency the sensitivity of each sensor is measured and compensated individually in manufacturing process. For the measurement of the temperature dependency a highly stable 1000 W/m^2 light source ($<0.3\%$ variance (during total measurement sequence)) is used. With each MS-56 measurement report (Temperature Dependency Test Report) is issued indicating the measured temperature dependency of responsivity (each output at every 10°C compared against output at 20°C).

Temperature dependency Typical figures

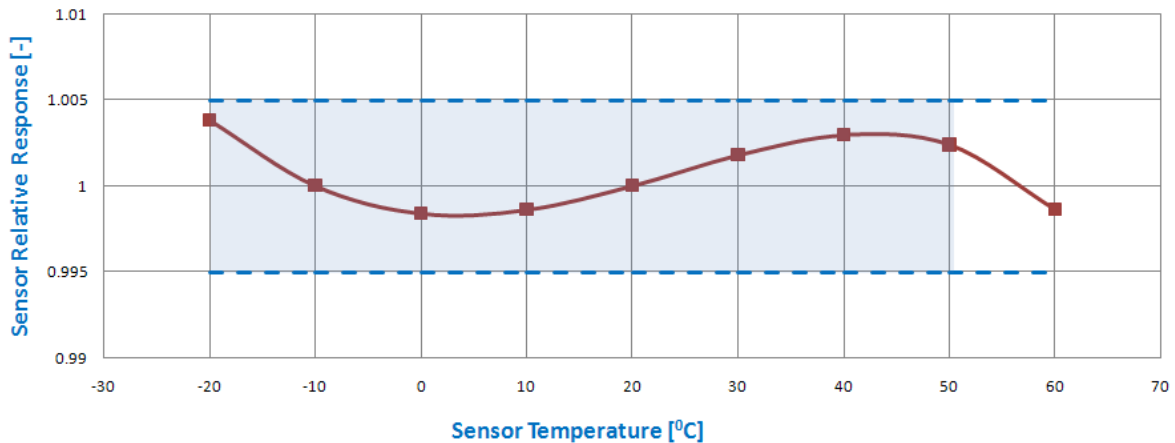

Figure 7-2. Temperature Dependency Measurement

3. Zero Offset (Typical)

Due to a well balanced and light weight detector construction the Zero Offset caused by changing instrument temperature is negligible. The typical Zero Offset was measured according to the ISO 9060 definition at a temperature response of 5K/h change in ambient temperature. A thermally balanced detector is important to guarantee the best measurement stability during variable environmental and solar irradiance conditions.

Zero Offset (5K/h)

Typical figures

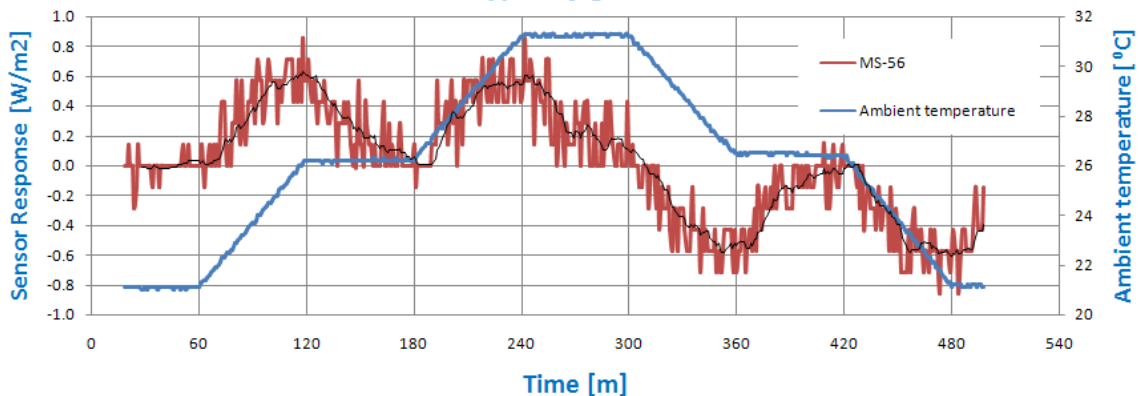

Figure 7-3. Zero Offset Measurement

7-3. Product Accessories

Table 7-2 Accessories List

Accessories	Details
Cable Length*	20, 30, 40, 50m
STR-21/22 Mounting Jigs	Fixing Ring
	Mounting Plate (3-holes)
Drying Cartridge	Drying Cartridge
Replacement Silica Gel	Replacement Silica Gel (desiccant) container (500g)

*Standard cable length: 10m

A-1. Symbols

Table A-1 Definitions of Symbols

List of symbols	Definitions	Units
E	Output Voltage	μV
S	Sensitivity	$\mu\text{V/W} \cdot \text{m}^{-2}$
t	Time	s
τ	Response Time	s
T	Temperature	$^{\circ}\text{C}$
I	Solar Irradiance	W/m^2

A-2. Thermistor Temperature Conversion Table

Table A-2 Temperature Conversion table for the Thermistor (44031, 10k Ω @25°C)

T [°C]	R [Ω]	T [°C]	R [Ω]	T [°C]	R [Ω]
-30	135200	0	29490	30	8194
-29	127900	1	28150	31	7880
-28	121100	2	26890	32	7579
-27	114600	3	25690	33	7291
-26	108600	4	24550	34	7016
-25	102900	5	23460	35	6752
-24	97490	6	22430	36	6500
-23	92430	7	21450	37	6258
-22	87660	8	20520	38	6026
-21	83160	9	19630	39	5805
-20	78910	10	18790	40	5592
-19	74910	11	17980	41	5389
-18	71130	12	17220	42	5193
-17	67570	13	16490	43	5006
-16	64200	14	15790	44	4827
-15	61020	15	15130	45	4655
-14	58010	16	14500	46	4489
-13	55170	17	13900	47	4331
-12	52480	18	13330	48	4179
-11	49940	19	12790	49	4033
-10	47540	20	12260	50	3893
-9	45270	21	11770	51	3758
-8	43110	22	11290	52	3629
-7	41070	23	10840	53	3504
-6	39140	24	10410	54	3385
-5	37310	25	10000	55	3270
-4	35570	26	9605	56	3160
-3	33930	27	9227	57	3054
-2	32370	28	8867	58	2952
-1	30890	29	8523	59	2854

A-3. Pt100 Class A Conversion Table

Table A-3 Conversion Table for Pt100 Class A (complying with JIS C 1604 1997)

T [°C]	R [Ω]	T [°C]	R [Ω]	T [°C]	R [Ω]
-30	88.2	0	100.0	30	111.7
-29	88.6	1	100.4	31	112.1
-28	89.0	2	100.8	32	112.4
-27	89.4	3	101.2	33	112.8
-26	89.8	4	101.6	34	113.2
-25	90.2	5	102.0	35	113.6
-24	90.6	6	102.3	36	114.0
-23	91.0	7	102.7	37	114.4
-22	91.4	8	103.1	38	114.8
-21	91.8	9	103.5	39	115.2
-20	92.2	10	103.9	40	115.5
-19	92.6	11	104.3	41	115.9
-18	92.9	12	104.7	42	116.3
-17	93.3	13	105.1	43	116.7
-16	93.7	14	105.5	44	117.1
-15	94.1	15	105.8	45	117.5
-14	94.5	16	106.2	46	117.9
-13	94.9	17	106.6	47	118.2
-12	95.3	18	107.0	48	118.6
-11	95.7	19	107.4	49	119.0
-10	96.1	20	107.8	50	119.4
-9	96.5	21	108.2	51	119.8
-8	96.9	22	108.6	52	120.2
-7	97.3	23	109.0	53	120.6
-6	97.7	24	109.3	54	120.9
-5	98.0	25	109.7	55	121.3
-4	98.4	26	110.1	56	121.7
-3	98.8	27	110.5	57	122.1
-2	99.2	28	110.9	58	122.5
-1	99.6	29	111.3	59	122.9



EKO Asia, Oceania

1-21-8 Hatagaya,
Shibuya-ku, Tokyo
151-0072 Japan
P. +81.3.3469.6711
F. +81.3.3469.6719
info@eko.co.jp
www.eko.co.jp

EKO North America

95 South Market Street,
Suite 300, San Jose,
CA 95113, USA
P. +1-408-977-7751
F. +1-408-977-7741
info@eko-usa.com
www.eko-usa.com

**EKO Europe,
Middle East, Africa,
South America**

Lulofsstraat 55, Unit 32,
2521 AL, Den Haag,
The Netherlands
P. +31 (0)70 3050117
F. +31 (0)70 3840607
info@eko-eu.com
www.eko-eu.com