

Suction cup SKS20 - Instructions

Please carefully read this information before using the instruments!

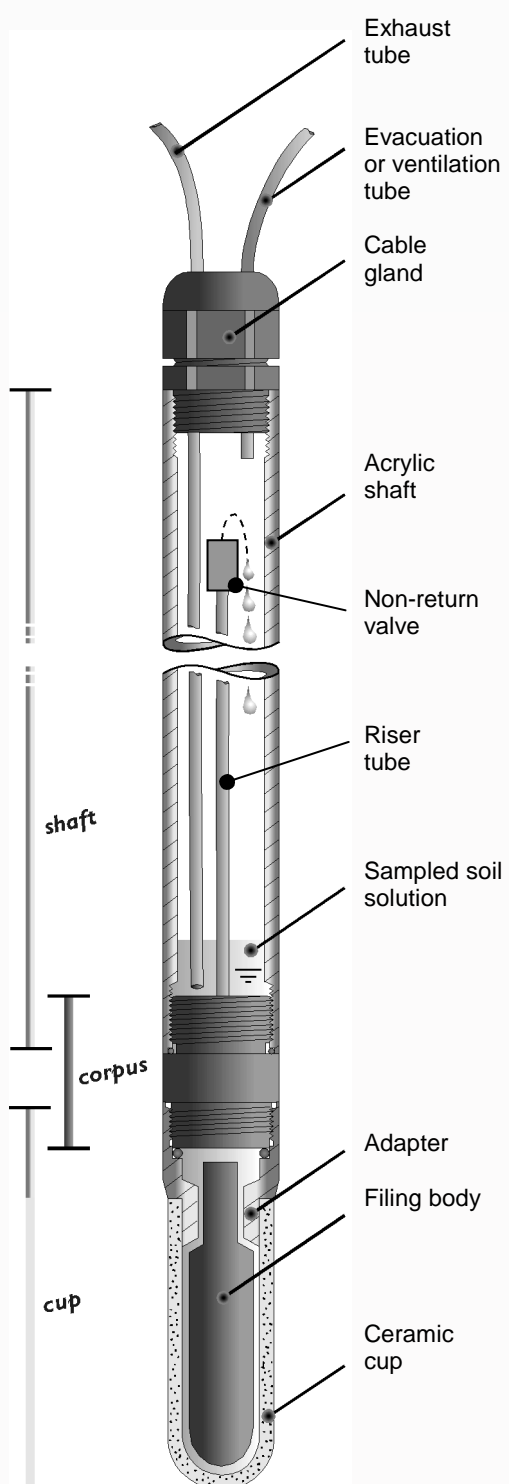

1. Description

The SKS20 suction cup assembles soil water solution inside the shaft. This allows an extraction down to a depth of 8 metres. No sampling bottles are necessary and the soil water solution is stored at soil temperature.

All parts having contact with the soil water solution are made of polyethylene or acrylic glass.

Caution!
The ceramic cup is fragile. Excessive load by impact, bending or pressure can cause break.

2. Rinsing the cup

Before first use rinse the cup with 0.5 litres of distilled water. We recommend not to wash the cup with hydrochloric acid!
After installation, the first several samples should be rejected.

3. Installation

Installation must be made so that the cup is in tight contact with the soil. Use an auger with 24 mm in diameter to drill a hole of the required depth.

In unstable soils and with long shaft lengths supporting jacket pipes might be necessary.

Insert the suction cup. The rubber disc pulled over the top end of the shaft will prevent surface water from running into the drill-hole and down the shaft. Lock both tubes with the plugs.

4. Extracting soil solution in the shaft

Keep the not marked tube, which is the exhaust tube, locked.

The tube with the blue mark is the evacuation and ventilation tube. To assemble soil water solution in the shaft, apply a negative pressure on the evacuation/ventilation tube and evacuate the shaft with the desired vacuum. The vacuum inside will draw up the soil water through the ceramic cup until it is disassembled.

To keep the volume low, a filling body is enclosed inside the cup.

5. Drawing up the solution out of the shaft

The solution is drawn out of the shaft through the not marked exhaust tube. To do so, remove the plugs from both the exhaust and the evacuation/ventilation tube. Then, apply either a negative pressure on the exhaust-tube or a positive pressure on the marked evacuation/ventilation tube. Relock both tubes with the plugs.

6. What to do in winter period

If a suction cup should remain installed during periods with temperatures below freezing point, the cup, shaft and tubes must be emptied to prevent frost damage. Please note, that in times free of snow but with air temperatures below 0°C, the area of frost declines from the soil surface into deeper soil horizons. As soon as water inside the tubes is frozen, the suction cup cannot be emptied anymore.

To empty the suction cup, completely extract the water left in the suction cup. Lock the exhaust tube with the plug. Attach a syringe to the evacuation/ventilation tube and press 20 ml of air into the cup to achieve a positive pressure of approx. 100 hPa. Then, also lock the evacuation/ventilation tube with the plug.

7. Maintenance and storage

For cleaning, wipe of the shaft with a moist cloth. The suction cups should be stored in a position where a deformation of the shaft is avoided. The ceramic cup should not be touched!

Technical Specification		Art. No. SKS20	
Shaft	Acrylic glass, Ø 25 mm	Cup type	SKA-100FF
Body	Acrylic glass	Cup size	60 mm length, Ø 20 mm
Filling body	Acrylic glass	Density	3.09 g/cm ³
Tubes	Polyethylene, outer diam. 4 mm, inner diam. 2 mm	WAF	6.9 %
		Cup porosity (Hg)	26.5 %
		Pore size (Hg)	0.08 µm