

ASI-16 V24 - All Sky Imager

Advanced Sky Imaging System - R 2024-11



Software & Hardware Manual

Release Version R 2024-11

Including "Release Notes" for SW v241108n (2024-11-08)

Change Notes / Release Notes:

v241108n (2024-11-08):

!!!-!!!: New "ASI16-Installer_v24" replaces previous "ASI-Manager" and "Support.exe".
New "ASI-Software" can be installed by using latest "ASI16-Installer_V24", only!
Previous "ASI-Managers" will NOT work to update any newer "ASI Software"!
New "ASI16-Installer_v24" also replaces previous "ASI_DHCP_Fix-It.jar" tool.

IMP: Life data cloudiness values displayed with one decimal place only.

FIX: Sometimes login to ASI GUI has required multiple (>5) tries to enter password.

FIX: Time configuration, interval setting lost after having switched to "Manual Time".

FIX: Time configuration, time was synchronized with NTP server even if deactivated.

FIX: Sometime changes in local ASI settings (capture, locale, ...) cannot be stored.
Sometimes shooting and FTP upload did not run, esp. after parameter change.

FIX: Old "life date" remain displayed in GUI even if "life data" function was disabled.

FIX: Sometimes shooting hang-up or GUI block after running for multiple (5-30) days.

FIX: Wrong internal link for CMS/Agent logo in Web-GUI.

FIX: Manuel reset of FTP connection did not work as should.

v240531n (2024-05-31):

NEW: GUI-Home: Cloud Analysis (CMS FCT) – Display of real-time analysis data.
See § 6.5, page 39.

NEW: Additional Capture/Shooting Template - Intervals: A= 5 Min., and B= 1 Min..
See § 6.8.2, page 44.

NEW: Remote access for ASI-16 V24 via CMS "REM" (VPN) encrypted tunnel.
See § 6.12, page 48.

IMP: Improved Peripheral Controller support for EKO MS-40S Pyranometers.
ASI SW, ASI16-Installer, CRM: Multiple minor improvements and fixes.

Table of Content

1	<i>Introduction</i>	6
1.1	Overview	6
1.2	Intended Use, Qualified Installation	6
1.3	Read This First - Part A - Before start working with an ASI	7
1.3.1	Your "ALL-IN-ONE" login name and password, for all CMS services:	7
1.3.2	Step-by-Step Procedures for Initial Client (End-User) Setup:	7
1.3.3	CMS-CRM - Management Platform for Client and Imager Data:	10
1.3.4	DATA STORAGE - CMS DEFAULT - CMS FTP/S SERVER:	11
1.4	Read This First - Part B - Network & Electric Setup	11
2	<i>Important General Remarks</i>	12
2.1	This Operator Manual	12
2.2	Scope of Delivery: Check of Packaging and Content	12
2.3	Identification, Name-Plate, Technical Data	13
2.4	Use of Packaging, Waste Disposal, Recycling	13
2.5	User/Client Network Requirements - LAN - Network Data Storage	13
3	<i>Safety Warnings - Safe Installation</i>	14
3.1	Qualified and Trained Personnel	14
3.2	Critical Out-Door / In-Door Installation	14
3.3	Specific Safety Risks and Warnings	15
3.3.1	WARNING! - RISK OF INJURY OR DAMAGE BY ELECTRICITY	15
3.3.2	WARNING! - RISK OF INJURY DURING MECHANICAL MOUNTING	15
3.3.3	WARNING! - RISK OF ELECTRICAL DAMAGES AND PERSONAL INJURIES	15
3.3.4	WARNING! - RISK OF PERSONAL INJURY BY COMPONENTS FALLING DOWN	15
3.3.5	WARNING! - RISK OF DAMAGE THROUGH LIGHTNING STROKE	15
3.3.6	WARNING! - RISK OF DATA LOSS - NO "ZERO-TOLERANCE" USE	15
3.3.7	ADVISE! - TAKE SPECIAL CARE WITH THE GLASS DOME	15
3.3.8	ADVISE! - Special preparation for use near salty seawater air environment.	16
4	<i>CMS Internet Services: CRM - FTP - VPN</i>	17
4.1	How to connect to CMS Internet Services	17
4.2	CMS CRM: To check and manage imager and clients settings	17
4.2.1	"MyData": To manage data of "your" company / institute / organisation	17
4.2.2	"Imagers": Configure location, create LI/PW-sets, and more.	19
4.2.3	"Downloads": One-and-only source for CMS software, tools, and manuals:	21
4.3	CMS FTP: To up/download JPG images, docs and software	22
4.4	CMS DDNS: To access ASI Imagers via WAN (Internet)	23

4.5	CMS VPN/REM: To access ASI Imagers without port forwarding	23
5	<i>Imager Network and Software - Installation</i>	24
5.1	IT Administration - LAN (WAN) - Basics (Pre-Requirements)	25
5.2	HTTP Access to ASI-16 Imager Homepage	25
5.3	Setup of PC's / LT'S for Monitoring and Configuration	25
5.4	Network Storage (FTP, FTPS, SFTP, others)	25
5.5	Live Video Stream (viewing, recording):	26
5.6	ASI-16/52 Imager - Electrical and Network Hardware Connections	27
5.7	HELP: Common IP-Access problems after relocation	27
5.8	ASI16-Installer - The All-In-One Toolset for ASI-16 Maintenance	27
5.8.1	Solving IP Problems: ASI16-Installer "IP Check Feature":	29
5.8.2	STILL PROBLEMS to access, even via ALIAS-IP and DHCP-Fixit Tool?	29
5.9	ASI16-Installer - ASI Software/Config - Update & Restore	29
5.10	Step-by-Step Procedures - To perform e.g. a "Full Reset":	31
5.11	ASI16-Installer - Advanced Features	32
6	<i>ASI Imager Head Software (Check Configs)</i>	34
6.1	HELP: How to work best with this Operator Manual Section	34
6.2	ASI Imager Web Browser Access - Login Procedure	34
6.3	ASI-16 Main Page - Home Page - Summary	35
6.4	Home Page - Navigation and Data Content	35
6.5	Cloud Analysis (CMS FCT) – Life (realtime) Data Display	39
6.6	Imager Network - LAN Configuration	40
	WARNING - Local setting will get lost after each software update/restore! Register ALL imager settings in CMS-CRM, as soon as possible!	40
6.7	Imager Location, GPS Coordinates, Time Zone	41
	WARNING - Local setting will get lost after each software update/restore! Register ALL imager settings in CMS-CRM, as soon as possible! After making any change in CMS_CRM, re-run ASI16-Installer and perform a "Configuration Data Update" or a "Full Reset"!	41
6.8	JPG Image Capturing - Shooting	43
6.8.1	Template #11 and #12: For first-generation ASI-16 (V2015, V2018) only!	45
6.8.2	Template #21 - V24: For standard "Cloudiness Analysis":	45
6.8.3	Template #25 for continuous "Cloud Movement Analysis":	45
6.8.4	Template #26 for "Cloud Movement Analysis" each 10 Minutes:	45
6.9	Network Storage Settings for JPG (FTP, NAS, FileShare)	46
6.10	Backup Storage (Temporary Storage on Flash Memory)	47
6.11	Peripherals Controller (PeriCon Settings, Data Logger)	48
6.12	Networking - CMS DDNS (Dynamic Domain-Name) and VPN	50
6.13	Security Settings - User Accounts - Name/Password	51

WARNING - Local security Data are lost after each software update/restore	51
6.14 Security Settings - User Accounts - HTTPS	51
6.15 Security Settings - User Accounts - Name/Password	51
6.16 Service - Maintenance (Reboot, PeriCon Firmware Update)	52
7 Peripherals Controller, Hardware / Software	54
7.1 PeriCont - Hardware and Sensors - Summary	54
7.2 PeriCont - Hardware LED Status Signals	55
7.3 PeriCont - ASI GUI - General Settings	56
7.4 PeriCont - ASI GUI - Pyranometer Configuration / Data	57
7.5 Datalogger File - Datafield Codes - Command Codes	59
7.6 "PeriDatConv---.jar" - Peripheral Data Converter Tool	61
8 ASI-16/5n - Mechanical Installation Guide	62
8.1 ASI-16/5n Imager - Sample Mast-Mount Designs	62
8.2 Preparation for Mounting	62
8.3 Step-by-step Mounting Guide	63
9 Pyranometer Option - Hardware Installation Guide	67
9.1 Pyrano Mounting - Components	67
9.2 Mounting the Pyrano Mounting Arm to an ASI-16/5n	67
9.3 xxx:	69
10 Mechanical & Electrical Drawings	70
10.1 ASI-16/5n Mechanical Drawings	70
11 Service & Maintenance	71
11.1 ASI-16/5n - Hardware Reset after Severe Faults:	71
11.2 ASI-16/5n Peripheral Controller - Firmware Upgrade	73
11.3 xxxx	78
11.4 Spare Parts - Part Order Numbers - Refer to Price Table for details.	79
12 Commercials - Legals - License - Conformity	80
12.1 Terms of Warranty	80
12.2 Contact	80
12.3 Licenses, Liability, Confidentiality, Copyrights	81
12.3.1 MPEG-4 VISUAL TECHNOLOGY	81
12.3.2 LIABILITY	81
12.3.3 CONFIDENTIALITY	81
12.3.4 COPYRIGHTS	81
12.4 EULA - End User License Agreement - (V03)	82
12.5 EC - Declaration of Conformity	85

1 Introduction

1.1 Overview

CMS-Schreder "ASI-16 V24" is the latest and most advanced total sky imager for scientific and operational meteorology, atmospheric science, climate research and industrial solar energy operations, based on state-of-the-art network and web browser technology, "High Power over Ethernet" for most easy cabling, and a rugged outdoor proof housing.

Its camera head hardware features a robust coated quartz glass dome, 180°/360° fisheye optics, brut 6 megapixel resolution sensor with superb image quality, and an IR-cut filter to avoid degradation of the sensor by long time direct exposure to the sun disk.

ASI-16/55_ADV comes with built-in ventilation and up to 60W airflow heating, to minimize condensation on the glass dome and to quickly remove eventual raindrops and snow. The system has been tested for harsh environments from -40°C up to more than +80°C air temperature. Its double-cover design combined with forced ventilation will minimize risks of damage because of long time exposures to strong direct sun radiation.

Additional environmental sensors provide high precision temperature & humidity data, and (optional) solar irradiance data by a Pyranometer with digital ModBus interface. The integrated datalogger stores numeric data into jpg-image exif data and into csv files.

ASI-16 imaging software presents life stream videos via a user friendly web GUI, captures pre-scheduled all sky JPG pictures, and automatically transfers those JPGs to a network file storage via standard protocols (FTP, FTPS, SFTP). In case of network or network FTP storage down, the imager will temporarily backup JPG's and data on the built-in 4 GB CF memory, and will restart transfers as soon as the network is up again.

Combined with CMS "FCT-19/22 Cloud Analysis Software" (FindClouds Trinity) ASI JPG images are used to calculate cloud coverage ratio, cloud density ratios. Calculation of average cloud base height (CBH, with two ASI-16 combined), and cloud movement vector (CMV, direction, relative speed) are available as options. - For further details, limitations and restrictions please refer to the corresponding FCT-nn software documentation.

It's outstanding combination of advanced software and hardware makes CMS ASI-16 indisputably the top choice for atmospheric scientists and for solar energy industrials.

1.2 Intended Use, Qualified Installation

ASI-16 is intended to be used for capturing all-sky images in the visible spectrum, for online or later visual display, inspection and analysis of clouds during daytime. It shall be mounted at an elevated location with a best-possible 180° field of view to the sky and the horizon, and with a minimum of disturbing obstacles (trees, buildings, masts, ...).

1.3 Read This First - Part A - Before start working with an ASI

=====

1.3.1 Your "ALL-IN-ONE" login name and password, for all CMS services:

Your agent (distributor, integrator) has provided your personal "Login-Data".
If you have NOT received your LI/PW data, please contact your agent or CMS.
You NEED your LI/PW to access ASI-16 imagers and all CMS online services.

EXAMPLE, how the login-information from your dealer may look like:

Company Name: Institute for Climate Research, xyz.
Login-Name: 20123_3 to log-in to CMS-CRM and CMS-FTP services.
ASI LI-Name: LI20123_3 to log-in to the ASI-16 imager browser web-gui.
Password: AB23xy95! for ASI-16 web-gui, CDS-CRM and CMS-FTP.

The "LI" prefix in the username must be used for ASI Web-GUI login only.
Login to CMS-CRM and CMS-FTP requires username WITHOUT "LI" prefix.
This LI/PW shall be used for CRM, FTP and (LI...) for all your ASI imager systems.
Please carefully note above data. - You need it all time to access CRM and ASI-16.

=====

1.3.2 Step-by-Step Procedures for Initial Client (End-User) Setup:

- a) Read "1.3.3 CMS-CRM - Management Platform" on next page.
Login to CMS-CRM, with your all-in-one Client-ID / Password:
URL: <https://service.schreder-cms.com/crm/>
- b) In ./Download/ download, unzip, store and read latest ZIP/RAR, including ...
 - ASI-16_V24 software- and hardware-manuals and support documents;
 - ASI-16_V24 software installer and tools (ASI16-Installer_V24, Support);

READ this "Operator Manual" to understand **ALL** pre-installation procedures!

ASI is a "network device", requiring a LAN with qualified router & firewall.
Your LAN Router/FW must run a DHCP service to automatically allocate IP's.
Your LAN must have access to a stable NTP time server (e.g. pool.ntp.org).
Your LAN Firewall must allow access to one (or more) S/FTP server(s).
Your LAN Firewall must allow Internet access via some specified ports.
Contact your company IT department for preparation and support!

- c) **Log-in to "CMS-CRM", check and/or update/add all pre-set data.**

Read "1.3.3 CMS-CRM - Management Platform" on next pages!

Start with data in ./MyData (=Client), continue with data in ./Imager.

Check and update Imager Location(s) data (Name, GPS, Email).
GPS coordinated (LAT/LON/ELE) MUST be as precise as possible.
GPS data are used for shooting control and analysis software.
When operating multiple ASI, data must be set for/in each imager.

Check and eventually change time zone setting to your local time zone.

Check and - later, after testing - change "Default Data Storage".
We recommend to first keep "CMS Default" and test with CMS-FTP.
When testing was OK, you may change to your own S/FTP server.

Set server data in "MyData", and set Imager to "Client default data storage". Consider to use two S/FTP servers, the second FTP as "mirror".

Check and select a "Shooting Template" which matches to intended use. Notice: "Cloud Motion Analysis" requires fast pic intervals (15 seconds)! Select your Template in "MyData", and set Imager to ... "Client default."

TAKE YOUR TIME! - Some CMS-CRM data are critical for ASI operation!

- d) LAN Connection: ASI-16 imager requires its IP to be set by a DHCP service. ASI-16 and your PC shall be connected via a router/FW running DHCP. Through this router, ASI-16 and the PC must have access to Internet! DO NOT try to connect ASI-16 directly to your PC (peer-to-peer)! DO NOT set a "fixed IP" on/via the ASI-16 web-gui user interface!
- e) Connect ASI camera to CMS-HPoE-Box (ADV) or PoE-Injector (BAS). Connect power to CMS-HPoE injector. - Power-On. - **WAIT >2 minutes!**
- f) Start the latest "ASI16-Installer_V24" and wait till ASI(s) are listed. If not displayed after max. 30 sec., close ASI16-Installer and re-start. If still not displayed, find the ASI's IP by using an IP scanner tool.

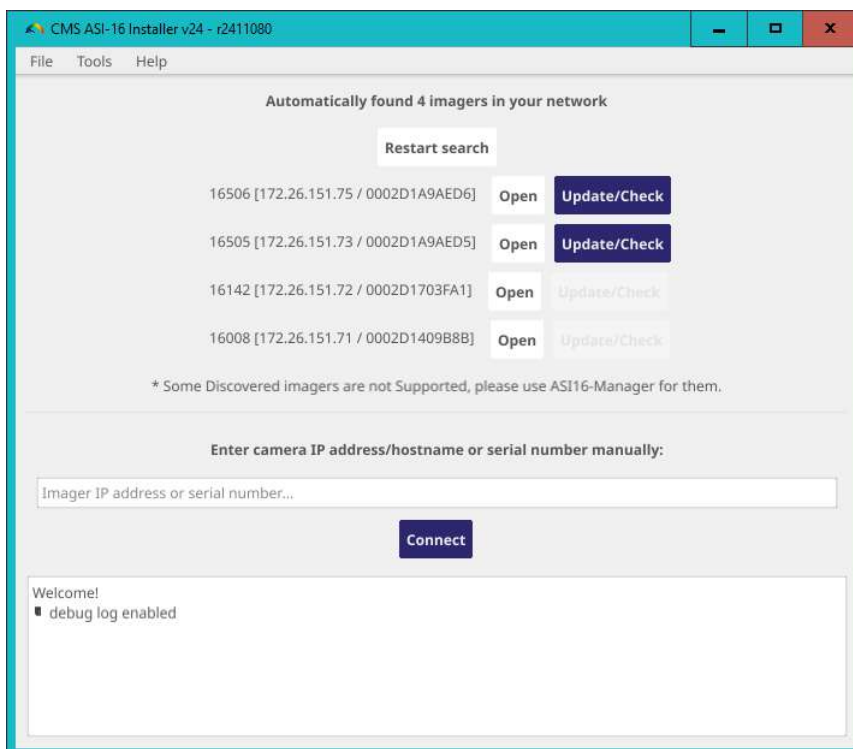

- g) Click on "Update/Check" for the ASI-16 you now want to update. OR (if not automatically found) enter ASI's IP or SN and click "Check". Wait 15-30 seconds, till you see a list of ASI data and parameters. **In case of problems refer to detailed explanation later within this manual!**

- h) Click "**Full Reset - if needed only**". - Notice and agree to security questions. This initial setup will , within one run, update ASI to the very latest software and will update all settings to the customized configuration as defined in CMS-CRM.

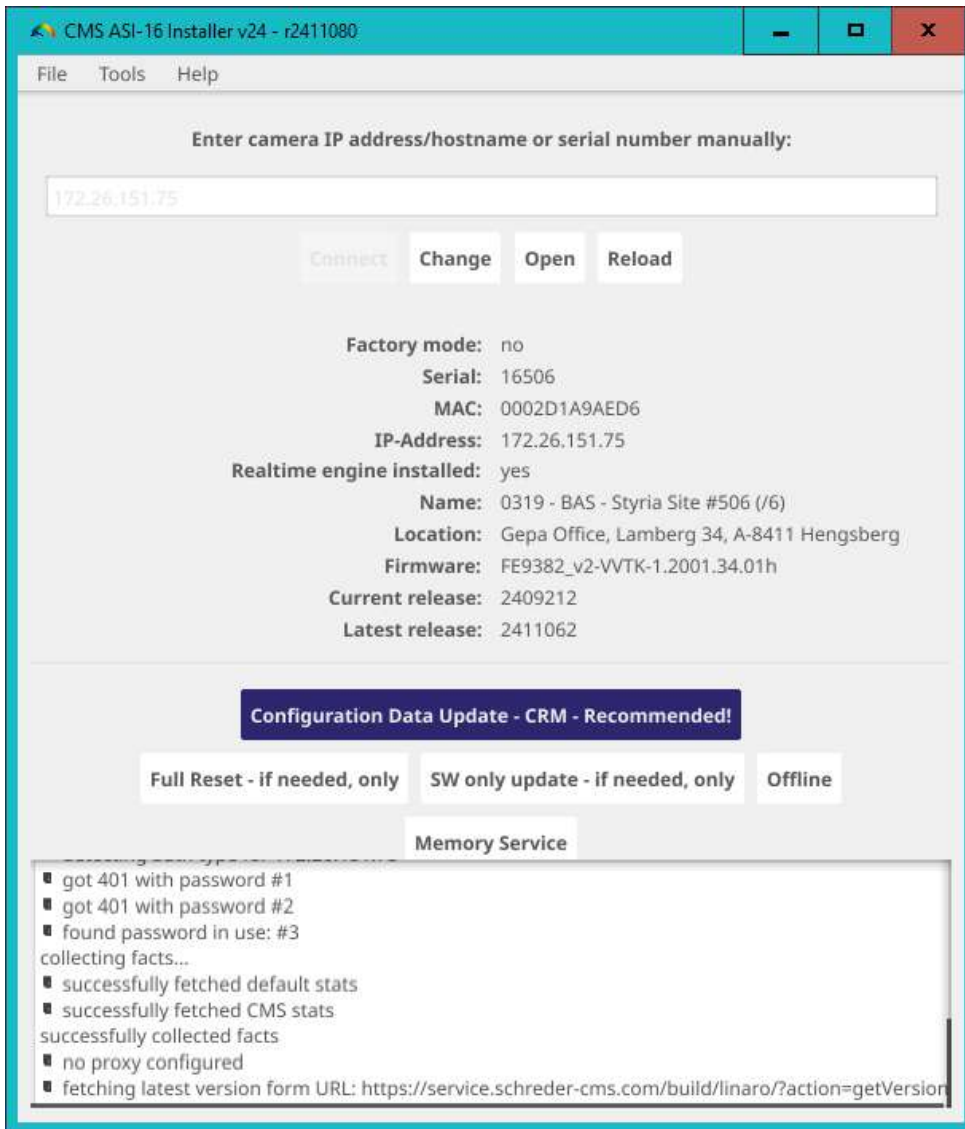

- i) Wait up to 5 minutes, till you see "Installation Fully Completed".
- j) Power-off ASI. - Wait >10 seconds. - Power-on ASI. - **WAIT >2 minutes!**
- k) On ASI16-Installer_V24, click on "Open", to open ASI Web-GUI.
OR ... : Open Web-Browser and enter IP of the ASI you just updated.
- l) Login with "All-in-one" Login Username/Password , as in CMS-CRM.
ASI-Imager Username starts with "LI" followed by your Client ID.
- m) After Login to ASI Web-GUI, press <CTRL-F5> about 2-3 times.
<CTRL-F5> refreshes browser cache to download new pages/frames.
Navigate through all ASI-Gui sites, and check all settings.

1.3.3 CMS-CRM - Management Platform for Client and Imager Data:

CMS-CRM is the central and main tool to manage your CMS hardware and software. - It allows to manage, pre-set and safely store all ASI configuration data, to lock and unlock hardware options, to retrieve FCT-19/200 cloud analysis software license keys, and to download all latest software, tools, manuals and (technical & scientific) side documents.

CRM URL: <https://service.schreder-cms.com/crm/>

Login: Your (all-in-one) Client-ID and Password.

/Clients: Register (create, update) end user customer/client datasets.
Maintain client/customer-specific generic imager parameters.
Maintain "client data" to be used for associated ASI cameras.

The screenshot shows the 'Shooting Templates - Image Parameters' configuration page in the CMS-CRM web interface. The browser address bar shows 'service.schreder-cms.com/crm/customers/show/3'. A yellow banner at the top reads '!!! CLIENT - SITE !!!'. The 'Shooting Template' dropdown is highlighted with a red box and contains '21 Standard 10min - Interval 1pic.'. Below it, 'Fixed quality' is set to 'Good' and 'Framerate' is set to '40 Mbps'. A yellow callout box contains the text: 'Select one [out of 9] well pre-defined shooting templates. All practically needed shooting settings should be covered. Avoid to set shooting parameters via ASI Web-Gui, only! Settings via ASI Web-Gui are lost after software updates!'. The 'Network - Default Settings (ASI GUI)' section is visible below. Under 'Default Network Data Storage', 'Net Server Type' is set to '- CMS Defaults -'. The 'Mirror / Fallback Data Server' section is highlighted with a green box. 'As Mirror' is selected, and a yellow callout box contains: 'Use "Dual Data [S/FTP] Server" mirror feature to ... distribute data automatically to two research sites; ... increase overall security against potential data loss; ... reduce downtimes on weak/instable IT networks.'. Below this, 'Net Server Type' is set to 'SFTP', 'Server address' is 'ftp2.gepaconsulting.at', 'Server port' is '21', 'User name' is 'g', 'Folder name' is 'CMS-FTP/bat-test_221024/asi16_life-bat', and 'Password' is masked with dots. A blue footer note states: 'For SSH-Key authentication please leave the password field empty and set up your keys on the imager. These keys will be persistent after a reset with ASI-Manager.'

/MyData: Maintain your own client/customer-specific generic imager parameters.
Maintain "client data" and templates used for associated ASI cameras.

/Imagers: **IMPORTANT!** - Data are used by "ASI16-Installer" configuration updates!
License-Key: For FCT-19/22 (FindClouds Trinity) Analysis Software.
Maintain imager-/ site-specific parameters (site name, gps/locale data).
Create additional personalized (ASI imager-specific) sets of LI/PW.
Offline-Package: For ASI-16 SW updates without stable Internet access.
For "Agents": Re-locate "your" imagers to your (new) client/customer.

/Downloads: Software tools, manuals and side documents for ASI-16 imagers.
License-specific SW downloads and documents for FCT (FindClouds ...).

DOWNLOAD IMPORTANT SOFTWARE-TOOLS :

ASI16-Installer: To locate ASI-16 IP's and to update data and software.
To find ASI via "Alias IP" when connected peer-to-peer.
To check camera IP (... DHCP ...) configuration status.
To reset IP status to "Get IP automatically" if required.
For disaster recovery: Access ASI "backup memory".

1.3.4 DATA STORAGE - CMS DEFAULT - CMS FTP/S SERVER:

FTP URL: ftp.schreder-cms.com
Login: Your (all-in-one) Client-ID and Password.

Upon delivery, your ASI will send JPG images to a CMS provided FTP server.
This CMS FTP service is free of charge for a storage capacity up to 10 GByte.
Without special agreement, data on CMS FTP are stored for about 18-24 months.

After having setup your own S/FTP please change settings in CMS-CRM.

Please install a professional FTP client, like FileZilla.
Create a local directory for your CMS-FTP down-loads and up-loads.
For example: C:\CMS-ASI-FTP\ or [YourServer]:\CMS-ASI-FTP\.

/asi16_data: JPG images sent by all "your" ASI-16 imager(s).
To be used before setting up your own FTP/NAS.

=====

1.4 Read This First - Part B - Network & Electric Setup

After receiving your ASI-16, at very first you shall set it up indoor in an office place!

Usually in most larger organisations / institutes / companies an "IT department" must register the ASI imager MAC-IDs, configure firewall and router rules, maybe has to open ports if you want to use some CMS web-services (CMS DDNS, CMS FTP, online updates, etc.), and (if later on you do not want to use CSM-FTP) setup an internal S/FTP server.

You should setup and test your internal IT/NET infrastructure with your ASI imager running indoor in your office. Move the ASI to its final outdoor location only after IT network setup is completed and all ASI functions are tested to work as expected.

2 Important General Remarks

2.1 This Operator Manual

This Manual is an essential and integrated part of the equipment. The information herein will help to you to maintain the equipment in safe and stable working conditions.

Before starting to work with the equipment you must read and understand this manual.

Keep this manual close to the equipment, during the entire life cycle of the equipment. Any person which intends to works on the equipment, must first read and confirm having understood this manual. In case of that this manual has got lost or damaged, please contact your CMS sales representative or CMS in Austria for receiving a new copy.

Modifications on the equipment and on this manual are subjected to the manufacturer or his authorized representative, only. You shall use original spare parts as supplied or approved by the manufacturer. - What so ever non-authorized modifications and use of what so ever non qualified spare parts will lead into loss of warranty.

2.2 Scope of Delivery: Check of Packaging and Content

Upon receiving the delivery, immediately check the packaging and the content for any visible damages. If so, make pictures for evidence and document in writing, and send your damage claim to your forwarder, to your CMS agent and to CMS in Austria, for qualified damage insurance claims. - Also check completeness of the scope of delivery, and immediately report any eventually missing or damaged components.



The "External T/RH Sensor" comes in a separate box, and MUST (!!!) be connected to the matching 4-pin connector at the bottom side of the "Peripheral Controller" module!

2.3 Identification, Name-Plate, Technical Data

The ASI-16 imager is marked with a "Name-Plate Sticker", indicating the equipment name and model code (ASI-16/52), year and month of manufacturing, serial number (16nnn) and the LAN adapter MAC-ID. This name plate sticker is applied inside the cover hood, and smaller stickers on the "Peripherals Controller Box" and the bottom of the imager head.

CMS ASI-16_V24 Imager System Technical Data & Specifications ASI-16/55-Advanced & ASI-16/15-Basic			
Imaging Sensor Chip	1/1.8" Progressive CMOS	LAN Network Type	100 BaseTX Ethernet (RJ-45) -
Imaging Sensor Resolution	3096 x 2094, 5 Megapixel	Network Protocols	IPv4, IPv6, TCP/IP, HTTP,
Useable Resolution	1920x1920 (Fisheye)		(HTTPS), FTP, FTPS, SFTP, DHCP,
Field of View (useable view)	180° / 360° (150° / 360°)		NTP, DNS, DDNS, RTSP/ RTCP,
Lens, Focal Length, Aperture	Fixed-focal, f=1.47mm, F2.2		SMTP, PPPoE, SNMP, SSL,
CMS ASI Optical Dome	Strong Quartz Glass, coated	Software Updater, Tools	CMS ASI installer, CMS toolkits
Imager Spectral Range	Visible Spectrum	Data file network upload	S/FTP/S server (file server)
Minimal Illumination	0.18 Lux @ F2.2 (Color)	Realtime video stream	MJPEG, H.265, H.264
WDR Techn., Dynamic Range	WDR PRO (Enh.), 100 dB	Graphic User Interface	Web Browser, WIN-10/.../11
Ventilation, heating (./5n only)	80 m3/h, 60W heating power	Power supply system	[H]PoE (Power over Ethernet)
Environmental Sensor (./5n only)	Temp/RH, Sensirion SHT85	Power supply input	[CMS-H]PoE, 100V - 240V AC
Pyranometer Interface (./5n only)	digital, ModBus (RS-485)	Power consumption	./5n: 15W/80W; ./1n: 15W;
Internal data backup memory	Industrial MicroSD CF, 4GB	Operating Temperatures	-40°C (-25°C) to +80°C (limited)
Mounting rod dimensions:	DM: 37mm to 40mm (max)	Environmental Protection	IP66, IP65, EN50155,

2.4 Use of Packaging, Waste Disposal, Recycling

Packaging material should be stored and used for later safe transportation and shipping.

Upon end-of-life of whatsoever materials, equipment, components, accessories and wear parts, all such parts must be recycled and/or disposed according to applicable local laws and regulations at the country of operations. - During warranty time, defective spare parts must be returned to CMS, or must be recycled/disposed as above, subject to corresponding notice and advise by CMS or your local CMS agent in advance.

2.5 User/Client Network Requirements - LAN - Network Data Storage

For continuous stable operation, client MUST connect ASI via a LAN/WAN router with DHCP service enabled, and send data to a network attached (S)FTP(/S) network storage. ASI imager shall be set to "Get IP automatically", getting the IP from LAN DHCP service. Setting ASI to "Fixed IP" will cause problems, especially after each software update!

CMS does NOT warrant stable operation, when connecting ASI without a router and without DHCP service enabled. Except for temporary maintenance, do NOT connect "peer to peer", especially not to a standard office- PC running a standard MS-Win OS.

Network data storage via FTP server:

Initial testing and low data load use: Access to free-of-charge CMS FTP account.

Long-term operation, high data load: Corporate file server or dedicated RAID-5 NAS.

- In most cases such (NAS-) servers already include and/or run a "FTP server" app.

- ASI will upload data via FTP. Client apps can access data via "file share" in real-time.

- In such setup there is no need to regularly download/sync data via a FTP client.

3 Safety Warnings - Safe Installation

3.1 Qualified and Trained Personnel



This equipment must be installed, configured operated and maintained by such personnel ONLY, which has/have all necessary theoretical and practical knowledge, education and training to perform such tasks, especially sensitive and potentially risky or dangerous tasks related to mechanical, electrical and IT-related works.

Before starting to work with the equipment the operator or engineer must fully read and understand this manual. Knowledge of the technology and works involved, and detailed knowledge and understanding of the entire content of this manual is a fundamental requirement for safe and stable long lasting performance of this equipment.

3.2 Critical Out-Door / In-Door Installation

A part of ASI-16 components (Imager Head) is prepared to be installed in harsh out-door environment. But another part of the components (HPoE Injector, DC Power Supply, network router cable) MUST be installed in in a dry indoor-like environment.

Check the below description to identify outdoor-prepared and indoor-only components:

	<p><u>OUT-DOOR PREPARED:</u></p> <ul style="list-style-type: none"> - ASI-16 All Sky Imager - Rod mounting footer - 3 screws and rings, M8 - External T/RH Sensor (a)
	<p><u>OUTDOOR <-> INDOOR:</u></p> <p>Data/Power Cable (HPoE & CAT5) Standard cable length: 20m Extension cables: Upon request</p>
	<p><u>IN-DOOR - ONLY !!!</u></p> <ul style="list-style-type: none"> - Special CMS HPoE Injector - Power Adapter (48VDC / 90W) - AC Power Cord (100V-240V) <p> WARNING: Must be installed at dry and safe place with an indoor-like environment.</p>



(a) External T/RH (Temperature - Humidity) Sensor:

ASI-16/n5 comes with an external high precision T/RH sensor. Shall be mounted into a meteorological "Radiation Shield".

NOTE: The CMS standard T/RH sensor "TRH45-STA" is NOT fully resistant against salty sea water, like on a vessel or when mounted close to a seawater shore.

OPTIONAL: T/RH sensor "TRH47-CEP" with enhanced protection against "corrosive environments". - Available upon separate order.

3.3 Specific Safety Risks and Warnings

3.3.1 WARNING! - RISK OF INJURY OR DAMAGE BY ELECTRICITY

Before starting any works, have the DC power adapter disconnected from main power!

3.3.2 WARNING! - RISK OF INJURY DURING MECHANICAL MOUNTING

When working on an elevated platform or a ladder, you must wear qualified personal safety equipment (safety shoes, safety helmet, safety rope, roof railings) and tools.

3.3.3 WARNING! - RISK OF ELECTRICAL DAMAGES AND PERSONAL INJURIES

The components above marked as "INDOOR-ONLY" (special CMS HPoE Injector, Power Adapter, AC Power Cord) must be installed at indoor at a dry and safe place, or inside a water- and humidity-tight electrical cabinet. It MUST NOT be installed at an open outdoor place with the risk of exposure to water (rain, snow, ...) or high (condensing) humidity. - Water or high humidity may cause direct and indirect damage to the equipment and the network, and may lead to injury and even death by electrical shocks.

3.3.4 WARNING! - RISK OF PERSONAL INJURY BY COMPONENTS FALLING DOWN

Mechanical installation of the ASI-16 imager (mounting on an instrumentation mast or an instrumentation platform) must be performed by personnel experienced and trained in such work, and with qualified knowledge about the situation at the installation site. Personnel must ensure to mount the equipment at a stable and safe site, must properly fix and secure the equipment from falling down, even in the case of special environmental conditions (strong winds, tornados, earthquakes, ...). The equipment falling down may cause severe injury and even death.

3.3.5 WARNING! - RISK OF DAMAGE THROUGH LIGHTNING STROKE

Typically the ASI-16 will be installed at an elevated outdoor location, which increases the probability of a direct or indirect lightning stroke. It is technically impossible to protect the equipment from receiving or forwarding the lightning stroke pulse. The equipment DOES NOT INCLUDE any counter measures. - It is subject to the customer's decision to implement qualified measures at the point-of-entry (LAN connection, AC power connection), to protect his own internal or peripheral equipment, and to connect or not-connect the mounting rod/platform to earthing / ground.

3.3.6 WARNING! - RISK OF DATA LOSS - NO "ZERO-TOLERANCE" USE

The equipment is NOT qualified for zero-tolerance applications. Although thoroughly tested, CMS cannot exclude residual risks of short term or long term data losses and/or system down. The equipment MUST NOT be used for super-critical applications.

3.3.7 ADVISE! - TAKE SPECIAL CARE WITH THE GLASS DOME

The "glass dome" is a critical sensitive optical component. Do not touch the dome with any tool, do not let it drop down, and use multiple soft wet tissues without any pressure when cleaning, to avoid scratches. A scratched dome is not subject to warranty replacement!

3.3.8 ADVISE! - Special preparation for use near salty seawater air environment.

When installed near salty sea water, like on a vessel or close to a seawater shore more salt desert/lake, after some weeks or months some (outer) parts of the ASI-16 Imager will start to show corrosion. - To avoid later **severe damage**, especially on all outer electrical connectors, the CLIENT must ensure regular qualified protection treatment and regular check and maintenance. - Later damages because of lake or protection treatment and/or lake of maintenance are NOT covered by warranty!

ADVISE: To reduce the risk of corrosion damages, especially on and inside electrical connectors, IMMEDIATELY after receiving and installing the ASI-16 imager, the CLIENT shall apply **thick layers** of a marine-use qualified **sticky "dielectric grease"** to all connectors and plugs, outside at the screw areas, **BUT ALSO INSIDE - AT THE PINS!**

4 CMS Internet Services: CRM - FTP - VPN

CMS-Schreder provides some Internet-based services, which run on a CMS service-server connected via a powerful and fast hub, providing 24/7 supervised operations.

CRM-service (Customer Relation Management) is IMPORTANT for "daily use", as settings directly influence behaviour of ASI software updates / restores via the ASI16-Installer.

Other CMS services (FTP, DDNS, VPN/REM) are provided for customer convenience, only. Those services may help the customer to speed up installation, or enable more easy access via Internet. Later on the customer may continue to use the CMS server services, or the customer may setup his own services on his own network and IT infrastructure.

4.1 How to connect to CMS Internet Services

Before or upon delivery of your imager you should have received an email with your "Personal Username/Password-Set" (LI/PW). - There is ONE individual LI/PW for each CMS agent/client account, or for a client sub-account generated by a CMS agent.

Username: The CMS account number of the agent/client (for example 20123).
Imager LI Name: "LI" followed by the same account number (for example LI20123)
Password: A combination of letters and digits, issued by CMS or by the agent.

This is the "one-for-all" LI/PW to be used for Imagers as well as for Internet Services.

With this LI/PW the customer/agent can access ALL imagers allocated to his account.

NOTICE: An Imager Login Name MUST start with "LI", followed by the account number.

With the same LI/PW you can access CMR to check and manage imager settings.
And you can use it to access your CMS-FTP-storage place through any FTP-Client

4.2 CMS CRM: To check and manage imager and clients settings

Open THIS WEB URL: <https://service.schreder-cms.com/crm/>

To log-on, enter your "one-for-all" LI/PW (Username=Client_ID, and password).

Now, depending on if you are an "AGENT" or a "CLIENT", at the top line you will see a number of "navigation buttons". - When logged-in as "Client" ("End-User"), on the top bar you will see "MyData", "Imagers" with list of your imagers, and "Downloads".

When logged-in as CMS/EKO "Agent" (distributor, integrator) you also will see "Clients", which allows to you - as Agent- to manage all your client-accounts for existing "clients", add new "clients", and re-locate (setup) client's ASI-16 imagers. - The Client_ID for new clients will be generated automatically upon "UPDATE, and cannot be changed or deleted. Other parameters can be can be changed or added later on, also by the client himself.

4.2.1 "MyData": To manage data of "your" company / institute / organisation

Company Name, other names, address, email, phone, notes:

Contact data for after sales service and support by your agent and/or by CMS.

Imager Default Data, Shooting Template, ...:

Will be used for default configuration of your ASI imagers, if you run just one ASI.

If you use more than one ASI, you must configure each ASI on the "imager" pages.

Network - Default Settings (for data storage server):

To be used as default configuration of all ASI imagers, if you run one FTP server, only.

Assigned ASI Imagers: A table of all imagers allocated to your account.

Click on the "Serial Number" to immediately open the corresponding "Imager" site.

!!! CLIENT - SITE !!!

Shooting Templates - Image Parameters

Shooting Template: 21 Standard 10min - Interval 1pic

Fixed quality: Good

Framerate: 40 Mbps

Select one [out of 9] well pre-defined shooting templates. All practically needed shooting settings should be covered. Avoid to set shooting parameters via ASI Web-Gui, only! Settings via ASI Web-Gui are lost after software updates!

Network - Default Settings (ASI GUI)

Default Network Data Storage

Net Server Type: - CMS Defaults -

Mirror / Fallback Data Server

As Mirror: [checked]

Net Server Type: SFTP

Server address: ftp2.gepaconsulting.at

Server port: 1

User name: g

Folder name: CMS-FTP/bat-test_221024/asi16_life-bat

Password:

IMPORTANT GENERAL ADVISE:
"Client" site: Pre-define all or most general settings.
"Imager" site: Set "Use client settings" when possible.

For SSH-Key authentication please leave the password field empty and set up your keys on the imager. These keys will be persistent after a reset with ASI-Manager.

Press the green [UPDATE] button to permanently store all your changes.

4.2.2 "Imagers": Configure location, create LI/PW-sets, and more.

To change settings for this imager, permanently. New Settings will be transferred to the imager at the next FULL-RESTORE (!) by using the ASI16-Installer. CRM settings will replace all eventual local changes on the imager via the imager Web-Gui! - New LI/PW and other parameters will be transferred also by an ASI16-Installer FULL-RESTORE !

Imager #16504

Client Company: 90002 - Gega Consulting

ASI Main Type: 55: ASI-18/55 Advanced V2024

Imager MAC-ID: 0002D1A4DE56

Imager HW/FW: FE9382_v2-VVTK-1.2001.34.01h

PeriCont Version: MK05-1512

PeriCont FW-Rel: Not_defined1

CMS Adm Note:

Client Note:

Super-Agents: No Groups defined

[Change](#)

Imager Mount-Site Location

Use Client Loc.:

Mount-Site Name: CMS 24029 - ADV ML01 - Styria Site #4 (v6)

Site Address/Loc: Gega Office, Lamberg 34, A-8411 Hengsberg

LAT (Latitude): 48.89045600

LOX (Longitude): 15.41927700

ELE (Altitude): 352

Timezone: GMT+01:00 Amsterdam, Berlin, Rome, Stockholm, Vienn

Daylight Saving:

NTP Server: pool.ntp.org

Email (Technical): ggapst@gepaconsulting.at

[Open in Google Maps](#)

Dynamic DNS - VPN Service

DDNS Port (8080): 8080

DDNS Domain: http://16504-55.asi.schreder-cms.com:8080

IP Address: 91.112.148.242

Last Update: 2024-03-05 14:08:02

Last Online: 2024-02-19 21:11:02

VPN Domain: https://16504-55.vpn.asi.schreder-cms.com

VPN Online: No

Imager Head Calibration

Fisheye - X-Axis: 976 (Default: 976)

Fisheye - Y-Axis: 1000 (Default: 1000)

RGB - Red Gain: 14 (Default: 14)

RGB - Blue Gain: 4 (Default: 5)

Saturation: 60 (Default: 70)

Shooting Templates - Image Parameters

Shooting Template: - Client default -

Fixed quality: Good

Framerate: 4 Mbps

Imager Access Accounts +

Username	Type	Password
CLI LI90002	administrator	

Network Data Storage (FTP/S)

Net Server Type: - Client default data storage -

Client Company: The Client/Customer (or the Agent) allocated to this Imager.
 ASI Main Type: Version of ASI Imager Head (11/... Basic, 51/..., 52/..., 55/ ADV),
 Imager MAC-ID: The MAC-ID of the imager head, important for your firewalls.
 Imager HW/FW: Low level firmware (operating system) of the ASI imager head.
 PeriCont Version: Hardware version of the [advanced] "Peripheral Controller" (box).
 PeriCont FW Rel.: Original Firmware version of the "Peripheral Controller" (box).
 CMS Adm Note: Notes to be entered by CMS Schreder Administrator, only.
 Client Note: Notes to be entered by the Agent or the Client.

Imager Mount Site Location: Imager location title and subtitle, GPS, time zone, ...:
 GPS coordinates and time zone are important for shooting and analysis.
 Uncheck "customer location", to change settings for multiple imagers.

- Dynamic DNS: All entries are "read-only", for check and copy/paste only.
- Domain: The CMS provided DDNS domain name (URL) of this imager.
The ASI imager will use the Alternate HTTP Port 8080,
If necessary set-up "port translation" on your firewall / router.
- IP Address: Latest updated WAN IP address of the ASI imager.
- Last Update: Last time the Imager has sent an IP update ping with a NEW IP.
- Last Online: Last time the Imager has sent any IP ping (indicating "be-alive").
- Image Calibration: DO NOT CHANGE any of the settings herein!
CMS has calibrated image sensor data before delivery!
Change of pre-defined settings may reduce image quality!
- Shooting template: Select template which matches best to intended use of data.
- Image Quality: To select JPG compression level and network bandwidth limit.
As "better" setting, as better image quality, but as larger file size.
For FCT cloud analysis software we recommend to use "good".
- Imager Access Accounts: Enter or change up to two additional LI/PW for this imager.
The Username(s) MUST begin with an ALPHA symbol!
New or changed LI/PW can be used AFTER next UPDATE
or RESTORE of the imager by using the latest ASI16-Installer.
- Network Data Storage: "Client default data storage" or imager-specific FTP server(s)

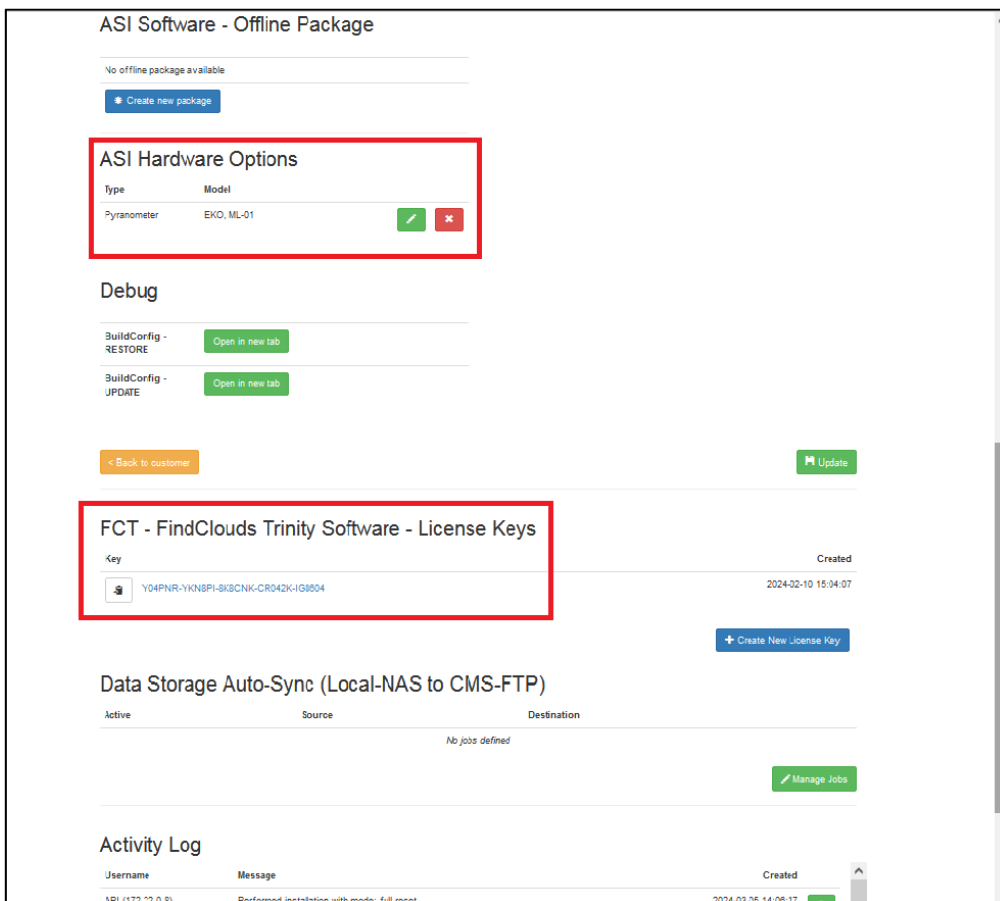

- ASI Hardware Options: Only available after purchase of "Pyranometer Option".
To select a specific Modbus Pyranometer Model/Version.
Necessary for ASI imager to connect to the Pyranometer.

Press the green [UPDATE] button to permanently store your changes.

Offline Package: To generate and download a "software update package".
Only for clients / installations with very strict firewall regulations.
Only for updates, if the ASI16-Installer has no stable internet access.

Step 1: "Create a new package" - Select as needed.

Step 2: "Download" - Download ZIP package to your PC.

Move this ZIP-file to a PC (storage) "within the strong firewall".

Run ASI-Manger on the this PC "within the strong firewall".

Set the ASI Manager to "Enable OFFLINE-Mode in any case".

Select imager via "Update/Check". Start "Install offline".

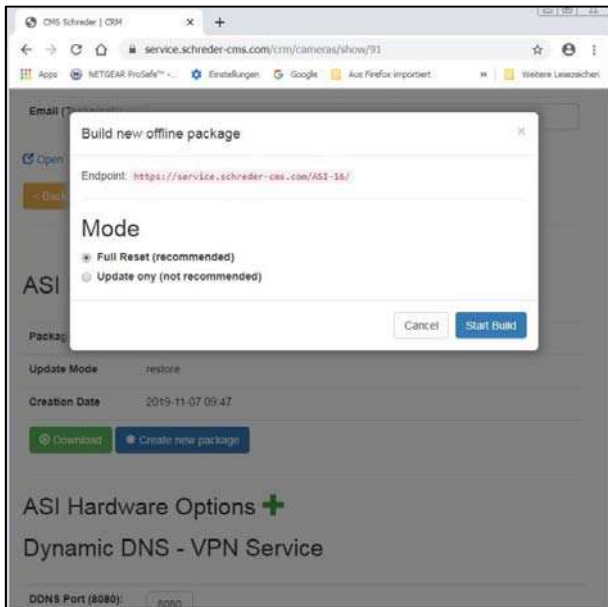

FCT - FindClouds Trinity Software - License Keys:

Available only after purchase of an FCT analysis software license:

To be entered (copy/paste) into the "FCT camera configuration.

Necessary to enable FCT to analyse images from "this" ASI imager.

Activity Log: Show automated (API) activities, like updates and restores.

Also allows to manually enter multiple remarks with time stamps.

For example to log eventual problems, defects and solutions.

Press the green [UPDATE] button to permanently store your changes.

4.2.3 "Downloads": One-and-only source for CMS software, tools, and manuals:

The "one-and-only" source to get (download) all latest software, tools, release notes and user manuals for CMS-Schreder cloud imaging (ASI) and cloud analysis (FC) products.

Content is explained in detail on "<https://service.schreder-cms.com/crm/downloads>".

4.3 CMS FTP: To up/download JPG images, docs and software

Preparation for using CMS-FTP:

Install and/or use a professional FTP-client, for example FileZilla or PowerCute.

URL: <ftp://ftp.schreder-cms.com/>

Login: Username/Password : Use your "one-for-all" LI/PW (Client_ID, password).

Your LI/PW will automatically access/open your personal CMS-FTP storage place.

To download JPG images, navigate in the "/asi16_data/" directory structure.

There is a subdirectory for each imager, and below a subdirectory for each day.

For example: .../asi16_data/ asi_16017/ 20161130.

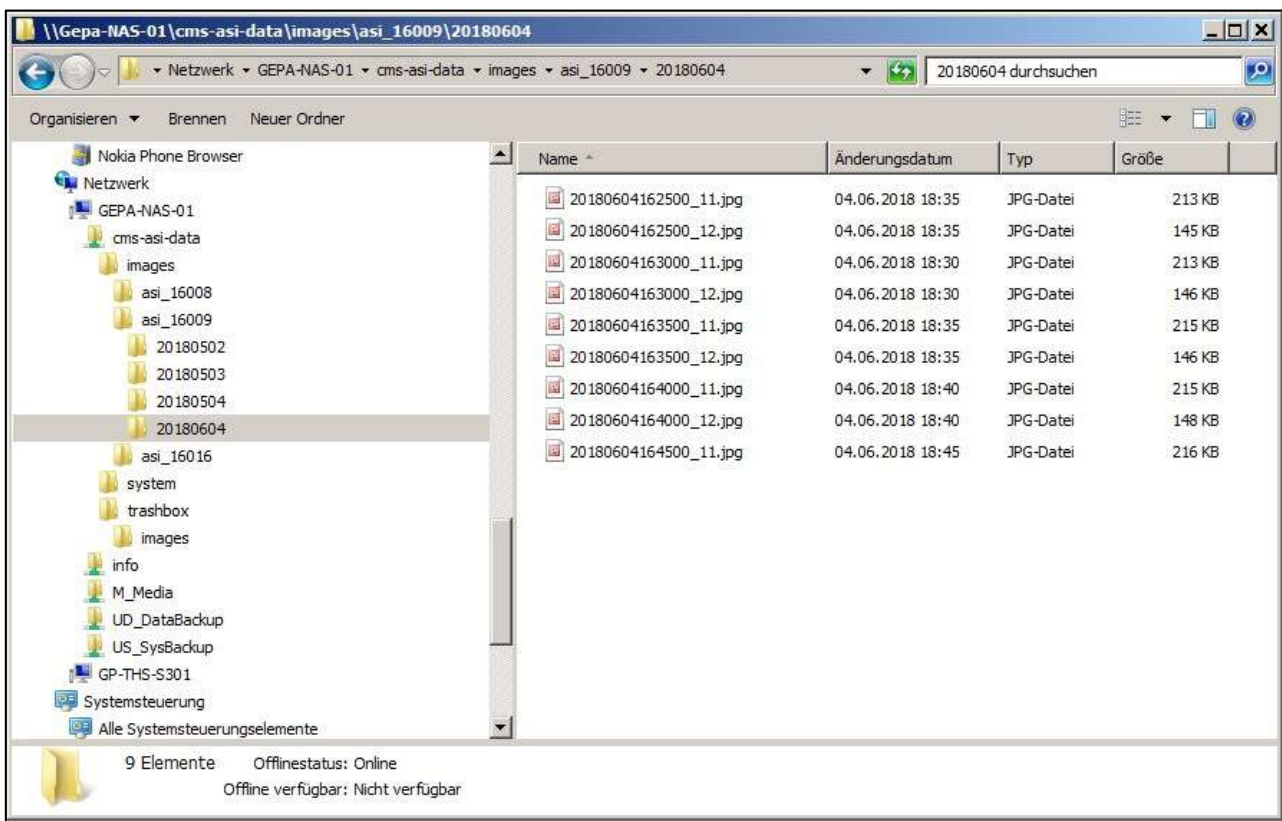

Other directories can be used to store or exchange whatsoever other data.

CMS-FTP must be considered as a "working storage", not as a long time archive.

**FTP Data are archived for MAXIMUM 12-18 months, and then relocated or deleted.
To avoid data loss, it is your responsibility to download data min. each 8 weeks.**

If you want to use CMS-FTP as long-time archive, please contact CMS support.

4.4 CMS DDNS: To access ASI Imagers via WAN (Internet)

When activated and ports opened in Firewall, CMS-DDNS ("Dynamic DNS") allocates a ASI-unique "Domain Name" (URL) to a static or dynamic WAN-IP. - For example URL "16008-8b.asi.schreder-cms.com:8080" for ASI SN16008.

4.5 CMS VPN/REM: To access ASI Imagers without port forwarding

When activated, the ASI establishes an encrypted connection between ASI-Imager and CMS-Schreder CRM-Server. Then a remote user or CMS support can securely access the ASI via the HTTPS-URL as provided and shown in CMS-CRM.

5 Imager Network and Software - Installation

Before installing a new ASI-16 Imager to an outdoor location, we strongly recommend to run software and LAN network setup, online updates to the latest software, and a pre-test IN-DOOR, in the office! - LAN network configuration and software settings should be tested BEFORE moving the ASI-16 to its final outdoor location.

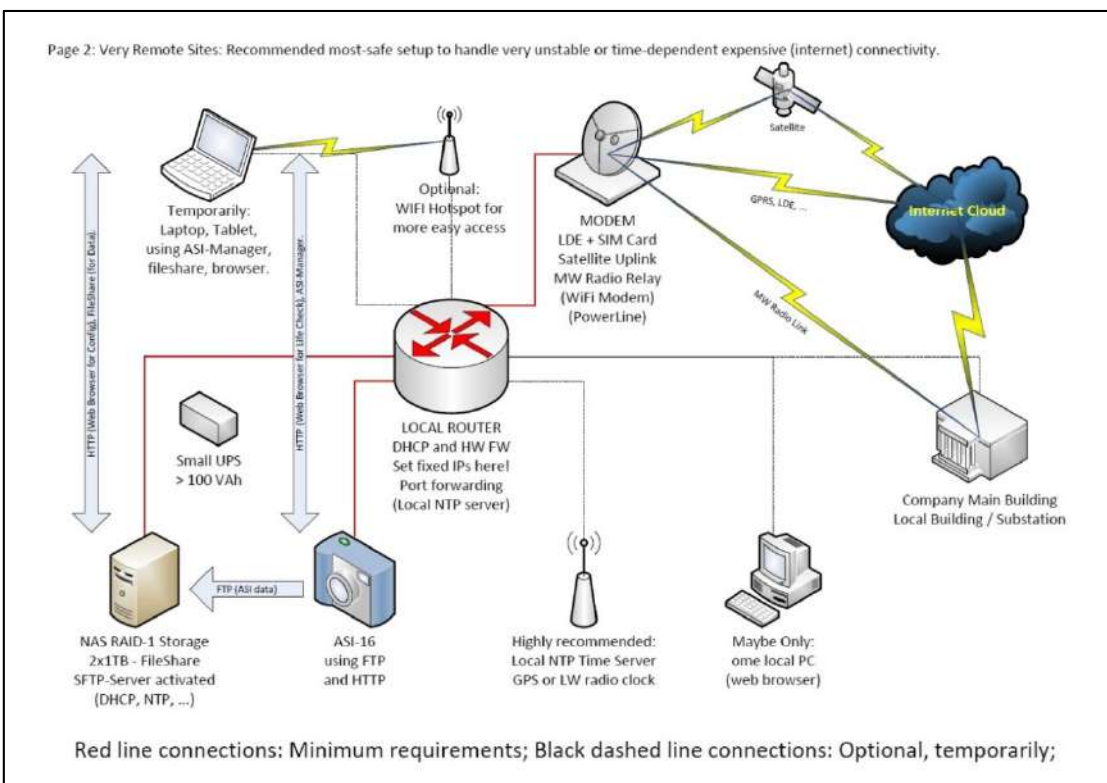
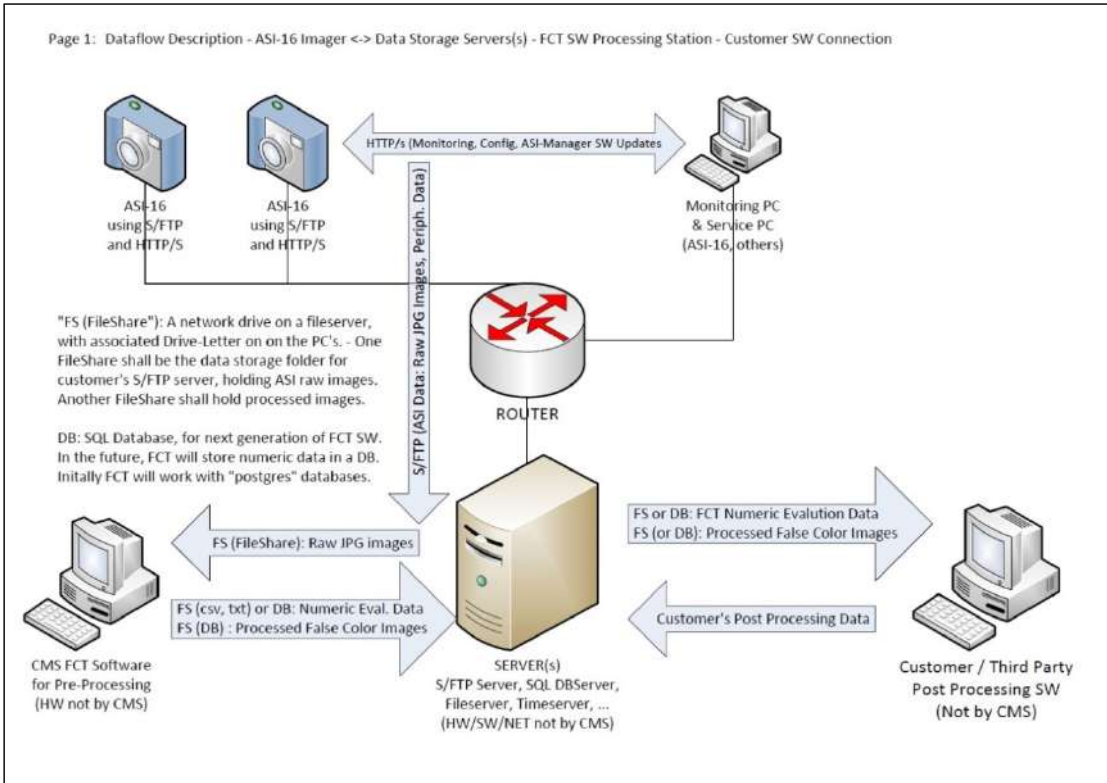

5.1 IT Administration - LAN (WAN) - Basics (Pre-Requirements)

CMS ASI-16 is a typical "Networking Device", basically comparable to other professional and industrial advanced "IP cameras". All external communication works via TCP/IP, Ethernet LAN/WAN and standard CAT-5 100 MBit (or better) network infrastructure.

ASI required to receive it's IP automatically from a DHCP service running on the LAN

Within the LAN, the imager can be accessed via its (primary and/or alias) IP address. In the WAN it can be accessed via CMS-DDNS URL, if opened by your IT administrator.

Online configuration, monitoring and online updates work via HTTP (primary port 80, secondary port 8080) or as defined in the Imager Configuration. - We recommend to keep the secondary HTTP port at 8080 and eventually translate this port at the router, as otherwise "online updates" from outside (via WAN and CMS-DDNS-URL) will not work!

5.2 HTTP Access to ASI-16 Imager Homepage

IT Administration should prepare measures, as (a) to open all necessary ports on the firewalls and routers, (b) implement a router rule at the DHCP server to allocate a fixed IP to the imager MAC-ID, (c) implement a router rule for 8080 port forwarding and port translation if the Imager HTTP homepage shall be accessed via WAN / Internet.

5.3 Setup of PC's / LT'S for Monitoring and Configuration

A local PC/LT is necessary for monitoring, configuration and SW updates, ONLY!
Daily operation of an ASI-16 does NOT require any PC with dedicated software.

This PC/LT must be connected to a network router/switch and to the internet. The below standard software (or comparable) must be prepared before working with the ASI-16.

- Install and/or update your web browser (Firefox, Chrome, Edge).
- Install and/or update Oracle JAVA: <https://www.java.com/en/>
- Re-check your web browser security settings. The web browser must allow to run plugins, especially run Java and QuickTime Viewer.
- Install a FTP client (e.g. FileZilla, <https://filezilla-project.org/download.php>). Check for FTP URL and login with your "CMS client account data".
- Copy "ASI16-Installer_V24.exe" to your desktop or any other convenient place.

All tools and manuals can be downloaded from CMS-CRM/Downloads.

NOTICE: Some Anti-Virus software may block or even delete some ASI-Tools!
In such case add ASI apps to your Antivirus software "Exception List".

5.4 Network Storage (FTP, FTPS, SFTP, others)

The ASI-Imager is designed to automatically send JPG images to a "Network Storage".

To permanently store captures JPG images, ASI must have LAN/WAN access to the (LAN- or WAN-) IP-address or the DNS-URL of a "Network Storage" (FTP or SFTP server).

Upon delivery, every ASI is set up to use the "CMS-FTP-Service", with a customer-specific FTP-Account (ftp://ftp.schreder-cms.com/ - Clients all-in-one Username/Password).

The customer is entitled to use this CMS-provided FTP account free of charge for a storage capacity of up to about 1 GB . - WARNING: CMS cannot guarantee availability and stability of this service, and cannot be held responsible for eventual loss of data. CMS FTP shall not be used as a long-term safe storage place. The customer shall be fully responsible for regular downloads and for clean-up and delete of old data.

Before switching to a customer-internal "Network Storage", customer's IT Administration, shall allocate such comparable services (FTP, ...) and storage capacity at any internal or external file server or NAS which can be accessed by the ASI imager. - The Network Storage must work with a LI-Name and Password. - The password must consider the "limited character set" for non-alpha/numeric characters used in multi-platform web browser interfaces.

5.5 Live Video Stream (viewing, recording):

Life Video Streaming works via Standard Streaming Ports.

We recommend to use Stream-2 for client's streaming applications.

URL: `rtsp://[username]:[password]@[ipaddress]:554/live1s2.sdp`



5.6 ASI-16/52 Imager - Electrical and Network Hardware Connections

Check the below image and description how to electrically connect ASI components:

 A photograph showing the ASI-16 imager, a white cylindrical device with a lens at the top. Below it are various connection components: a black coiled cable, a black power supply unit, a white HPOE injector, a yellow CAT-5 patch cable, and a black CAT-5 patch cable. The imager has 'ASI-16' and 'CMS' printed on it.	<ol style="list-style-type: none">(1) Connect the external T/RH sensor. T/RH sensor MUST be connected, as otherwise heating will not work!(2) Connect one end of the CMS HPoE cable to the ASI-16 HPoE jack at the bottom of the imager. - Before inserting the plug you need to remove the "rod mounting footer".(3) Connect the other end of the CMS HPoE cable to the CMS HPoE injector. CMS HPoE injector design may vary depending on version.(4) Use a CAT-5 patch cable (not included) to connect the RJ45 jack on the HPoE injector to your LAN (network) router/switch/port.(5) Connect 48V DC power supply cable to DC plug on the HPoE injector.(6) Power-on the AC/DC power supply (connect to 110V/240V AC supply).(7) Now the fan will start, and LEDs will start to blink.
---	--

5.7 HELP: Common IP-Access problems after relocation

Sometimes, against CMS clear advice, at "previous installation sites" the ASI IP-settings might have been changed from "Get IP automatically" (from DHCP service) to "Use fixed IP", with the fixed LAN-IP-settings matching to the "previous" network IP range. - As a result, most likely this ASI Imager cannot be identified in the "new" LAN, at least not by the typical most-easy to use tools (ASI16-Installer, NetScan, ...).

If the ASI16-Installer cannot find the Imager-IP after delivery or relocation, please do not waste time and **DIRECTLY** proceed with **RESETTING (!)** the ASI-16 locally set "fixed IP" as described under § 5.8. - In parallel talk to your IT to register the ASI MAC-ID to your firewall and to your DHCP service running on the LAN.

5.8 ASI16-Installer - The All-In-One Toolset for ASI-16 Maintenance

IMPORTANT NOTICE: Before using the ASI16-Installer, please ALWAYS check for the latest version. The latest V24 ZIP/RAR package can be downloaded from CMS-CRM.

"ASI16-Installer_V24" shall be used to identify one or more ASI-16 imagers (imager IP's) on the LAN (network), to open an ASI-16 in a WIN-10/11 web browser (Firefox, Chrome, ...), and to restore or update ASI-16 software and CRM configuration data.

After start the "ASI16-Installer" will search the local LAN for ASI-16 imager devices.

Search may take up to 1 Minute. The "list of imagers" will shows ASI-16 serial number, IP-addresses, MAC-IDs for each device found, and available imager-specific functions.

If the "Auto-Search" feature does not work, try to enter a known valid IP identified through another tool, and/or a remote DDNS/VPN/REM URL, and/or enter the ASI serial number.

Open: Opens ASI-16 Web-Gui in PC web browser, for ALL CMS ASI versions.

Update/... : Show SW status, enable SW updates, restore and IP/CF maintenance.

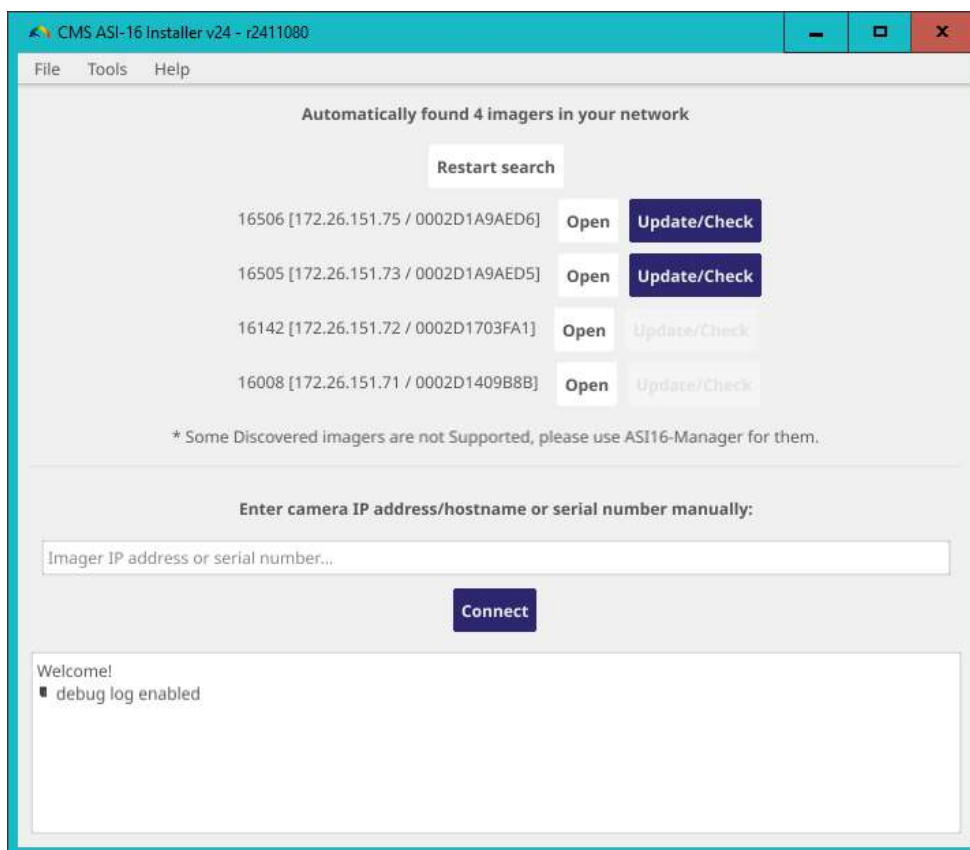

In most LAN (TCP/IP network) environments the (IP address of an ASI-16 device can be identified automatically. But "auto-detection" may NOT work in networks with very strong or exotic firewall settings, and/or when moving an ASI device with fixed IP settings to another network environment.

In such case check and fix the ASI by using a peer-to-peer connection and use "ASI16-Installer" and/or an advanced "IP/Port Network Scanner", and/or contact your network administrator.

"Check": After entering IP or URL, press "CheckHELP: ASI-IP cannot be identified via "ASI16-Installer"

The "automatic search function" requires the PC and the ASI-16 to have IP's within the same IP subdomain range, for example a range like "192.168.2.nnn". If the ASI-16 System/Network-Type is set to "Get IP automatically", usually the (router) DHCP service

will allocate corresponding IP addresses, automatically. - But, if the ASI-16 was set to "Use fixed IP ..." in networks with another subdomain range (e.g. "10.0.0.nnn", 172.16.150.nnn), and then the imager is connected to another network with another subdomain range, the ASI-manger search CANNOT identify and work with this "now strange" imager IP!

If ASI-16 was set to "fixed LAN IP" in one LAN, it likely cannot be accessed in another LAN. This can happen after moving an ASI to a new location, or you LAN does not run a DHCP service. This tool will reset the LAN properties to "Get IP automatically" (via router DHCP). After reconnection to a router and power-off/on the ASI will receive a valid IP.

You then can find the imager with its new IP via the "CMS-ASI16-Installer".
Or you can search for the camera IP with a "network scanner" tool.

5.8.1 Solving IP Problems: ASI16-Installer "IP Check Feature":

This function will try to reset ASI-16 to "Dynamic IP via DHCP" via its built-in "Alias-IP".
Try first to run this tool via standard connection (ASI-16 <-> Router, PC <-> Router.)

If it does not work, connect ASI-16 directly with a cable to your PC/LT, and try again.

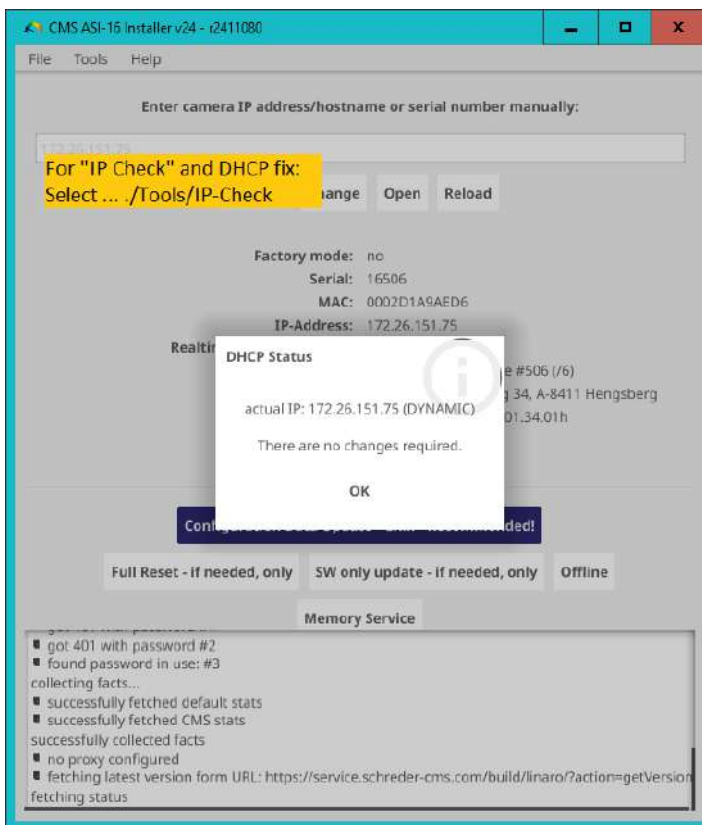

After running this tool you MUST power-off your ASI and re-connect it to the router.

5.8.2 STILL PROBLEMS to access, even via ALIAS-IP and DHCP-Fixit Tool?

Please contact your IT department to check network router and firewall configurations.

5.9 ASI16-Installer - ASI Software/Config - Update & Restore

In ASI16-Installer_V24 click on "open" near the ASI-device you want to update.

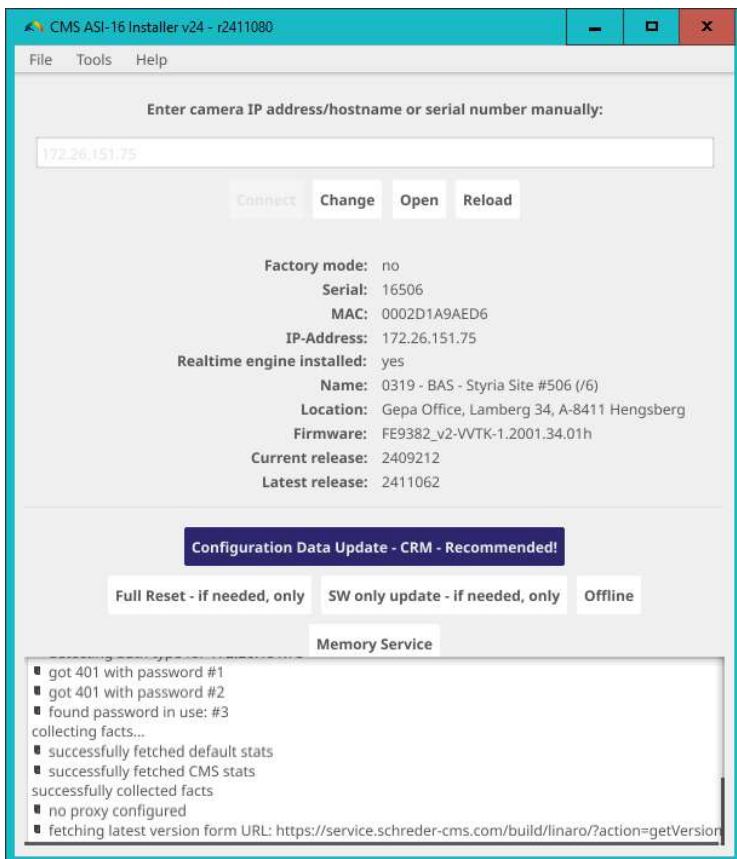

NOTICE: For online "Configuration Data Update" or "Full-Reset" or "SW only update", the PC running the ASI16-Installer MUST HAVE a stable connection to the "Internet", AND it must have a stable LAN/WAN connection to the ASI-Imager to be updated. - In case of NO or UNSTABLE connection we recommend to use "Install Offline", as described below.

"Configuration Data Update - CRM - Recommended!":

Transfers and restores ALL configuration data as pre-set and as stored in CMS-CRM. To be used IMMEDIATELY AFTER imager settings have been changed in CMD-CRM. Recommended steps: (a) Test new settings via ASI-16 Web-Gui. - (b) When OK implement those new settings to CMS-CRM - (c) Run ASI16-Installer "Configuration Data Update" - (d) Log-in to ASI-16 Web-Gui, press (CTRL-F5), and check all settings.

"Full Reset - if needed only!":

Multi-step firmware clean-up, re-installation of software and CRM configuration data.

- (a) Performing a "Deep Factory Reset" to remove eventually corrupted apps and data.
- (b) Complete (re-) installation of (latest) ASI software and all CRM configuration data.

- Necessary if, even after multiple power-/OFF/Wait-15sec/ON cycles ASI software shows stability problems, strange behavior, instable FTP uploads and/or slow Web-Gui access.

- Necessary if the client wants to use new features implemented in a new SW release.

WARNING: After a "FULL-RESET" all locally set or changed Login/Password-sets will be deleted and lost! Only data stored in CMS-CRM will remain permanent. So, first go to CMS-CRM and setup your camera-specific data (GPS location, Timezone, Shooting template, FTP-servers, ... eventually additional LI/PW in addition to your all-in-one CMS LI/PW). - The all-in-one CMS LI/PW will continue to work in any case.

5.10 Step-by-Step Procedures - To perform e.g. a "Full Reset":

- a) Login to CMS-CRM, with your all-in-one Client-ID and Password:
URL: <https://service.schreder-cms.com/crm/>
- b) In "CMS-CRM", check and/or update/add all pre-set data.
Start with data in ./MyData, continue with data in ./Imager.

Check and update Imager Location(s) data (Name, GPS, Email).
GPS coordinated (LAT/LON/ELE) MUST be as precise as possible.
GPS data are used for shooting control and analysis software.
When operating multiple ASI, data must be set for/in each imager.

Check and eventually change time zone setting to your local time zone.

Check and - later, after testing - change "Default Data Storage".
We recommend to first keep "CMS Default" and test with CMS-FTP.
When testing was OK, you may change to your own S/FTP server.
Set server data in "MyData", and set Imager to "Client default data storage".
Consider to use two S/FTP servers, the second FTP as "mirror".

Check and select a "Shooting Template" which matches to intended use.
Notice: "Cloud Motion Analysis" requires fast pic intervals (15 seconds)!
Select your Template in "MyData", and set Imager to ... "Client default."

TAKE YOUR TIME! - Some CMS-CRM data are critical for ASI operation!

- c) In ./Downloads/, download latest "ASI V24 Manuals and Software" zip package.
Un-zip package to a convenient location on your PC.
- d) LAN Connection: ASI-16 requires its IP to be set by a DHCP service.
ASI-16 and your PC shall be connected via a router/FW running DHCP .
Through this router, ASI-16 and the PC must have access to Internet!
DO NOT try to connect ASI-16 directly to your PC (peer-to-peer)!
DO NOT set a "fixed IP" on/via the ASI-16 web-gui user interface!
- e) Start the latest "ASI16-Installer_V24-B" and wait till ASI(s) are listed.
If not displayed after max. 30 sec., close ASI16-Installer and re-start.
If still not displayed, find the ASI's IP by using an IP scanner tool.
- f) Click on "Open" to open Web-GUI for the ASI-16 you want to update.
- g) In ./Imager/Capture/Shooting, de-activate (uncheck) in "./General".
In ./Imager/Storage/Backup-Management, click "DELETE-Uploads only".
Those settings/action make a "FULL RESET" faster and more safe.
- h) Power-off ASI for 15 seconds, power-on, wait about 3 minutes.
- i) Close and Re- Start "ASI16-Installer_V24" and wait until your ASI(s) are listed.

- k) In "ASI16-Installer", click on "Update/Check" for selected ASI imager.
OR (if not automatically found) enter ASI's IP or SN and click "Check".
Wait 15-30 seconds, till you see a list of data and parameters.
- l) In ASI16-Installer, click "FULL RESET", and confirm safety warnings.
- p) Wait up to 15 minutes, till you see "Installation Fully Completed".
- q) If the FULL RESET process is NOT completed after 15 Minutes, then ...
... close ASI16-Installer, and try sequence again at (k) for 2 times.
... if still not OK, power-off/wait-15sec/power-on an try again 2 times.
- r) After "... Fully Completed", wait 5 Min. before opening the ASI-GUI.
ASI-16 needs about 5 Minutes till all processes are fully loaded.
- s) Open your ASI-16 Web-GUI, go through all sites, and check settings.
Especially check ./Imager/Capture/Shooting, and apply your settings.
After opening (new) ASI GUI sites, press <CTRL-F5> about 2-3 times.
<CTRL-F5> refreshes browser cache to download new page layouts.

5.11 ASI16-Installer - Advanced Features

"Install offline": SW/Config Updates for ASI Imagers with limited Internet Access.

To be used if the PC/LT accessing the ASI Web-Gui and running ASI16-Installer has NO or an INSTABLE internet access to the CMS server.

- a) Log-on to CMS-CRM, open ./Imager/ and select the ASI imager to be updated.
- b) In CMS-CRM open "Offline Package"
- c) Select "Create a new package" - Select as needed.
- d) When done, select "Download".
- e) Download the "Offline Package" ZIP file to your PC.
- f) Move this ZIP-file to a PC (storage) "within the strong firewall".
Run ASI16 -Installer on this PC "within the strong firewall".
- g) Set the ASI Manager to "Enable OFFLINE-Mode in any case".
Select the ASI imager to be update via "Update/Check".
- h) Start "Install offline", and select the above described "Offline package ZIP".
- i) Proceed similar as with a regular "online installation"..

"Memory Service": Access to the ASI built-in temporary "Backup Memory".

To be used in emergency cases only, if ASI did not have access to the S/FTP server for more than a few days, and so has stored a huge amount of data to the Backup Memory" It allows to rescue those data directly from ASI built-in backup memory, without having to wait a very long time till all such data later on are step-by-step uploaded to FTP server.

After selecting and downloading data, ALL such data must be DELETED via "Memory Service" . Later on the "Backup Memory" shall be FORMATED by using the respective function in the ASI Web-Gui.

TOP BAR: "File / Settings":

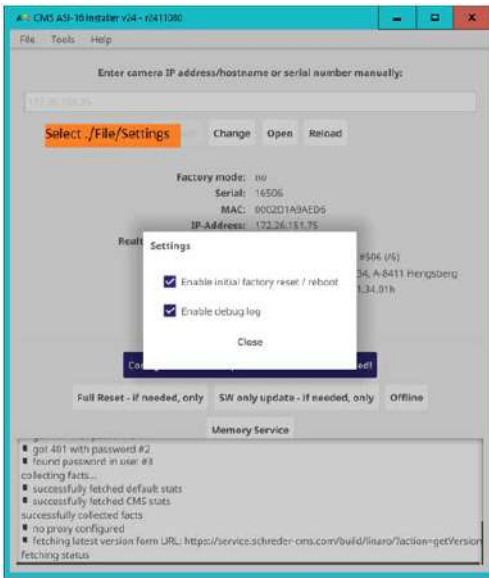

For CMS support and CMS bug analysis only!

Enable initial fact ... : Keep "enabled".

Enable debug log ... : Keep "disabled".

TOP BAR: "Tools / IP Check":

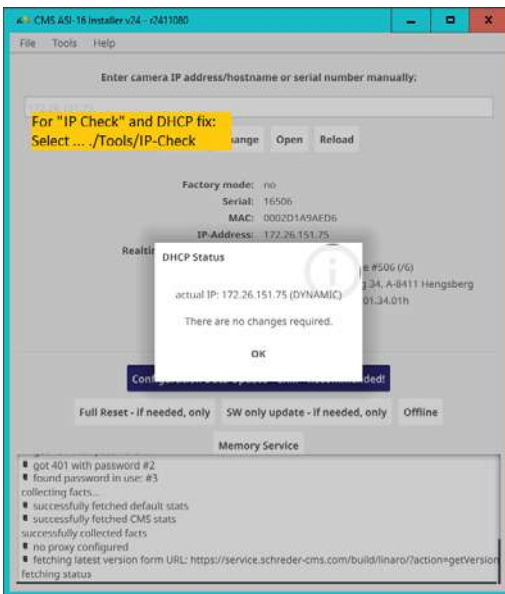

Replacement for previous "DCHP-FixIt" Tool.

If ASI was/is set to "Fixed IP", when confirming the request, it can be used to re-set IP-Configuration to "Get IP dynamically from DHCP".

After done, ASI must be power-off, wait >15 second, power-on again, and wait >3 min. for full reboot.

To find the ASI under its new allocated dynamic IP, ASI16-Installer must be close and restarted.

TOP BAR: "Tools / check offline package":

To check an ASI Software "Offline Package" previously generated in CMS-CRM.

Will display "package type", allocated ASI Serial Number and Software Version ID.

6 ASI Imager Head Software (Check Configs)

6.1 HELP: How to work best with this Operator Manual Section

When going through this section, in parallel you should have opened an ASI-16 in your web browser, and read and click in parallel. Please navigate by selecting a top navigation bar topic (Home/ Imager/ System/ ...) and then clicking one of the left side topics. - After changing one or more parameters within one page/frame, press <Save>.

6.2 ASI Imager Web Browser Access - Login Procedure

To access any ASI-16 you always need to log-in via a username and a password. You have received your "all-in-one" CMS-username/password from your distributor. This LI/PW allows you to access all your imagers, CMS-FTP and CMS-CRM.

Open your web browser (Firefox, Chrome, Edge). Enter the imager IP or URL.

As soon as requested, please enter your "CMS account" username and password. You can use one single "CMS client account" login for all your ASI-16 devices.

The Imager Login Name MUST START with "LI", followed by your client account number. Customer defined Login Names MUST START with at least one Alpha (A-Z) Symbol!

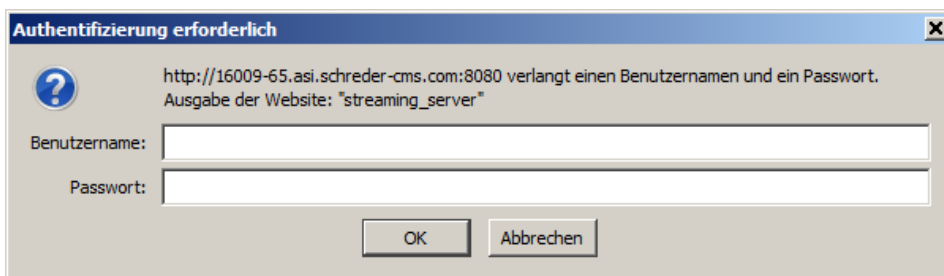

Please wait a while, as the first time login may take some time.

If the browser does not continue, press <F5> to refresh your browser cash, and re-enter Login name (LI) and Password (PW).

Depending on the browser and the LAN network connection, sometimes Login and Password (LI/PW) muss be re-entered up to 5 times till it is finally accepted.

If requested by your browser, please PERMANENTLY allow the installation of some plugins, the access to the website, accept of certificates, and maybe some more requests and warnings. Likely, after such warnings, you must press <F5>, and/or close and re-open your browser and press <F5> again (clear browser cache).

After some time you should see the CMS ASI-16 home page. - Especially when you connect the very first time, it may take more than 30 seconds.

As soon as you can see the ASI main page, we recommend to add this page IP/URL to your "browser favourites", for more easy access in the future.

If you can see the ASI-16 main page, but without an sky image view, then please recheck your browser settings. Likely you browser has blocked one plugin, or a plugin installation has been corrupted, or parts of the configuration has been corrupted during installation.

6.3 ASI-16 Main Page - Home Page - Summary

Within a LAN the "ASI-16 Homepage" can be accessed through its LAN IP address. As soon as the "Home Page" is displayed you should add this page to browser "favorites".

NOTICE: Sometimes, depending on web browsers, the screen may hang up or may look corrupted. In such case press [F5] and/or [Ctrl-F5] to refresh and/or clear browser cache. Sometimes, after pressing [Ctrl-F5], if the screen still looks corrupted, you first need to switch to another configuration screen, and then back to the screen requested.

After a reboot or restart it will take up to 5 minutes till all data, especially "peripherals data", will be available. - From time to time press "Ctrl-F5" to refresh web browser display.

6.4 Home Page - Navigation and Data Content

On the top and left side of the screen, the ASI-16 "Home Page" displays the most important real-time data and settings of the imager. On the top it also includes the "navigation bar" to access all sub-pages for configuration and maintenance. And in the centre it includes a "semi-live video-stream" of the camera.

The screenshot shows the ASI-16 Home Page interface. At the top left is the CMS Schreder logo. The main header displays 'CMS 24029 - ADV ML01 - Styria Site #4 (/6)' and location information: 'Gepa Office, Lamberg 34, A-8411 Hengsberg' with coordinates and an 'Open in google maps' link. A navigation bar includes 'Home', 'Imager', 'System', 'Help', 'Language', and 'About'. The central area features a semi-live video stream of the camera's view, with several red annotations: 'Local time timestamp' (ASI16504 2024/03/05 13:50:08), 'ASI-16 Hardware Type & Release', 'ASI software version: status, new release if available.', 'S/FTP server connection status. - JPG shooting active time.', 'Peripheral Controller Status', 'Peripheral Devices Status', 'High precision external T/RH sensor', and 'Optional: Pyranometer Status & Data'. On the left side, there are several data sections: 'Live View Size' (Auto, 100%, 50%), 'Capture JPG Image', 'All Sky Imager' (ASI-16/55 Advanced V2024) with serial number 16504, Ethernet MAC ID 0002D1A4DE56, last update 2024-02-20, sky imager SW 2402192, and update available 2402282; 'Data Storage Status' (online) with first and last JPG times; 'Peripherals' section showing connection status (online), hardware version (MK05-1912), fan status (ON), heater status (OFF), sensor status (ON), and temperature/humidity data; and 'Pyranometer' section showing connection status (online), CFG Type (16 - EKO, ML-01), RSP Type (6 - ML-01), and GH1 Latest Value (177 W/m²).

Top Side:

Location Text:	Description of Company, Location, and GPS Coordinates "Google Maps" will display a map with using the GPS data
Navigation Bar:	To select sub-folders for configuration and maintenance.
Home	The Imager Home-page (Main Page)
Imager	Imager-specific setting and functions
Location	Title text, GPS coordinates, timezone settings
Capture	Schedules and parameters for JPG image capturing
Storage	Network storage settings for JPG storage
Peripheral	Peripherals Controller settings, data logger
System	General System settings and functions
Network	IP configuration, DDNS configuration
Security	Temporary additional usernames / passwords
SD Card	Check and format SD/CF memory
Service	Reboot, generate reports, test tools
Help	The software part of this manual
Language	Select alternative GUI languages
About	CMS Schreder reference data

Left Side:

View Control:	To change the size of the live video display.
Local Capture:	Capture one JPG image for review and local storage
All Sky Imager:	Parameters and settings
Serial Number:	The serial number of this imager (camera head)
Ethernet MAC ID:	MAC ID of the ASI imager head ETH adapter.
Last Update:	Date and time of the last software update/restore
Sky Imager SW:	Software version of Imager / PeripheralController
New SW available:	Only displayed when new SW available for update.
Connection Status:	Status of connection to FTP data storage server.
First JPG at/after:	The time at or after the first JPG shot of the day
Last JPG before/at:	The time before or at the last JPG shot of the day
Peripherals:	Data and hardware status of Peripherals Controller.
Connection Status:	Status of connection to Peripheral Controller.
Peripheral SW:	Software Version of Peripheral Controller.
Hardware Version:	Hardware Version of Peripheral Controller.
Temperature/ Rel. Humidity/ Dew Point:	Data from external T/RH sensor.
Fan/ Heater/ Sensor Status:	OFF / ON / ERR (=Error, blocked, broken).
NOTICE:	High precision data require the T/RH sensor to be mounted in a "radiation shield". - Other ways of mounting will deliver low quality

data. BUT, the T/RH sensor MUST be installed and working in any case, as esp. temperature is necessary to control heating and fan.

Pyranometer: Available only after purchase of "Pyranometer Option".
Connection Status: Status of ModBus connection to Pyranometer.
CFG Type: Pyranometer type, as configured in ASI GUI
RSP Type: Pyranometer type, as reported from Pyranometer via ModBus.
Irradiance, last: Latest received irradiance value, no updates on the screen.

Below: Sample ASI Web-Gui, explaining system/hardware error indications:

CMS/Gepa Styria Test/Demo Site 3 (/3)
Gepa Office, Lamberg 34, A-8411 Hengsberg
LAT: 46.880456 N – LON: 15.419277 E – ELE: 382m [Open in google maps](#)

Home | Imager | System | Help | Language | About
ASI 16162 2023/07/24 16:54:09

Live View Size
Auto 100% 50%
Capture JPG Image

All Sky Imager
ASI-16/51 Advanced V2018

Serial Number: 16162
Ethernet MAC-ID: 0002d180AEF7
Last Update: 2023-01-23
Sky Imager SW: 2301231

Data Storage Status: on/off
First JPG at/after: 04:58
Last JPG before/at: 21:10

Peripherals

Connection status: online
Hardware Version: MK03-1808
Peripherals SW: 2012295

Fan Status: ON
Heater Status: OFF
Sensor Status: **ERR**

Temperature: 999.9 °C
Rel. Humidity: 999 %
Dew Point: 999 °C

Pyranometer

Connection status: online
CFG Type: 21 - EKO, MS-80S
RSP Type: 1 - MS-80S
GHI - Latest Value: 105 W/m²

Green: Both S/FTP servers ON
Orange: One ON, one OFF
Red: Both S/FTP servers OFF

Green/online: Peripheral Controller working.
Red/offline: Peripheral Controller defective,
... or ASI software [temporarily] corrupted.

ERR: [External T/RH sensor]
Not connected or defective.

PROBLEMS and FIXES:

(a) Top navigation bar not visible: Website not fully loaded.

Press <CTRL-F5> to trigger a web browser cache refresh.

(b) Life-image screen is black or blue, and does not display the life-video:

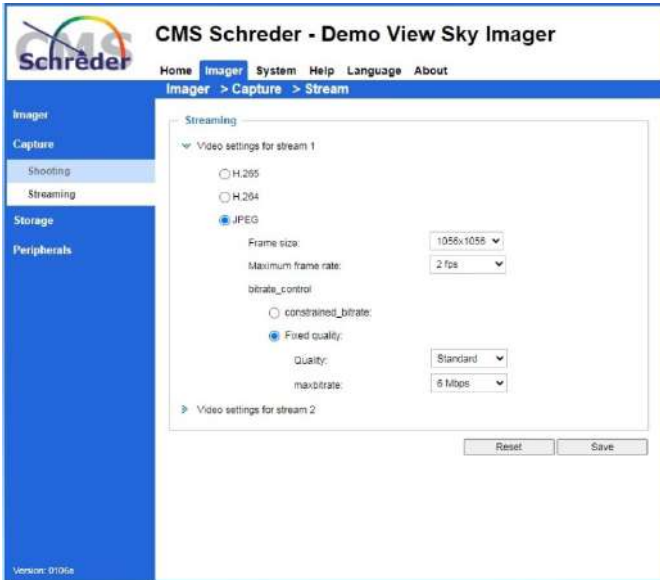

Image streaming settings got changed, sometimes after software RESET.

Navigate to `./Imager/Capture/Streaming`, select "Video ... stream 1", and select "JPG".

Check and eventually change JPG parameter configuration.

Click on "Save", navigate to `./Home`, and press <CTRL-F5> .

6.5 Cloud Analysis (CMS FCT) – Life (realtime) Data Display

Upon separate order CMS can provide “FCT-22 (FindClouds Trinity)”. FCT-22 means an optional modular WIN-based software package for numeric cloud analysis. It can process cloudiness ratio in %, a cloud movement vector, and cloud-base height by triangulation.

When running “FCT-22” in automated (real-time) mode, resp. latest FCT evaluation life-data can be displayed on the ASI-16 imager homepage.

Hereby operators can easily monitor the FCT SW operations status.

And, it is an enrichment for “Viewers”, when making some ASI home-pages available to an (internal or external) public audience, e.g. as special frame or as a link on the operator’s (company’s/ institutes) public homepage.

To activate “FCT Eval – Life Data”, in CMS-CRM and in ASI-GUI the parameter “Interval” must be set to “>=1”. For further details refer to “FCT-22 Setup & Operator Manual”.

Interval: The time interval where ASI is checking the primary FTP folder for new data in “fct-results.txt”.

Time: The last-results time (local or UTC) displayed at the ASI homepage.

Keep for min.: Data will be displayed ONLY if latest “fct-results.txt” data are not older than about “Keep for min”.

No “FCT Eval ...” frame to be shown, if latest data are older, or if the file “fct-results.txt” cannot be detected.

NOTICE:

The FCT-22 raw-image folder must be set/linked to the 1st Data-Storage (S/FTP) server. For further details on working with "shared folders" or use of an FTP client (e.g. WinSCP) please refer to "FCT-22 Setup and Operator Manual", download via CMS CRM.

6.6 Imager Network - LAN Configuration

TOP BAR: System - SIDE BAR: Network / Network Type:

The network settings should follow the regulations of your IT administrator.

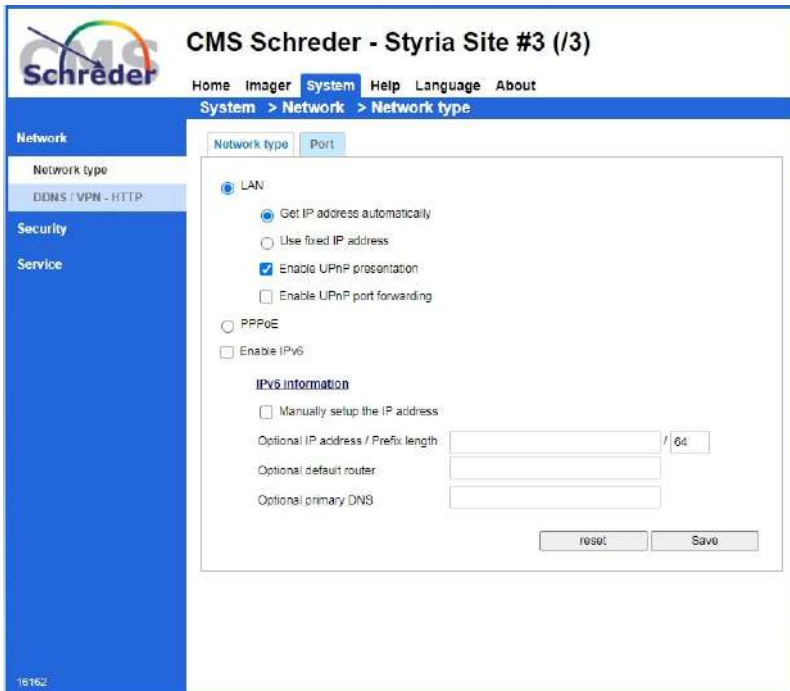

We STRONGLY RECOMMEND to use "dynamic IP allocation, by allocating the ASI fixed LAN IP via the Network DHCP Server (Main Router), by allocation the ASI MAC ID to the requested ASI fixed LAN IP and the ASI receiving its IP from the DHCP server. - We do NOT recommend to set fixed IP's on the ASI imager itself. Such regularly causes confusions when moving an ASI from one sit to another.

By default up delivery all are set to "Get IP address automatically!"

Description of the most commonly used setup with "dynamic IP":

- Navigate to /System/ Network/ Network-type.
- Set LAN to "Get IP address automatically".
- Click "Save" at the bottom, and close the web browser.
- Power-off ASI-16 for about 15 seconds, by disconnection DC power supply power cable.
- Start "ASI16-Installer" again, and let it search for ASI imagers.
- Now your (new) ASI-16 Imager should be displayed in the ASI Manager list.
- Click on "open" to login and open the selected new imager in your web browser.
- Proceed with "Login", software update, and with basic system setup.

**WARNING - Local setting will get lost after each software update/restore!
Register ALL imager settings in CMS-CRM, as soon as possible!**

6.7 Imager Location, GPS Coordinates, Time Zone

TOP BAR: Imager - SIDE BAR: Imager/ Location:

Location settings and Time settings MUST be configured according to the installation site. Parameters are used to calculate time of sunrise, sunset for capturing start/stop, and calculation of the position of the solar disc within each individual JPG image.

If you have setup correct data in CMS CRM, those data are transferred to ASI after each ASI16-Installer "FULL RESET". If data in CMS-CRM are NOT correct, you must manually check and correct settings after every "FULL RESET".

The screenshot shows the CMS Schreder - Styria #1 (I2) web interface. The main content area is divided into two sections: 'Location' and 'Time Configuration'.
Location Section:
- Company Name: CMS Schreder - Styria #1 (I2)
- Location: Office, Lamberg 34, A-8411 Hengstberg, G. Lempels
- Latitude: 46.87283333 N (with a dropdown menu and a 'ddd.ddddddfff' placeholder)
- Longitude: 15.45415587 E (with a dropdown menu and a 'ddd.ddddddfff' placeholder)
- Elevation: 382 [m]
Time Configuration Section:
- Time zone: GMT+01:00 Amsterdam, Berlin, Rome, Stockholm, Vienna, Madrid, Paris (dropdown menu)
- Enable daylight saving time
- Starting time: 2016/03/27 02:00:00
- Ending time: 2016/10/30 03:00:00
- Keep current date and time
- Synchronise with computer time
- Manual
- Automatic
- NTP server: time.windows.com
- Updating interval: One hour
At the bottom right of the form are 'reset' and 'save' buttons.

Company Name:

A descriptive text, to be displayed on the web page and stored within JPG images.

Location:

A descriptive text, to be displayed on the web page and stored within JPG images.

Latitude, Longitude, Elevation:

GPS coordinates and elevation above sea level, stored with JPG images.

GPS coordinates and elevation are very critical for the operation of the imager and for CMS FCT analysis software.

Enter GPS data with most high precision, minimum "nn.123456" precision.

Email Technical: Email of a person in charge of service and maintenance of this ASI.

Time Configuration: NTP Server - Local time to be used within ASI-16 SW:

ASI-16 must have permanent (!) access to a qualified Time-Server (NTP-Server). Either a public NTP via Internet, or a local NTP installed inside your network (LAN).

You MUST (!) set the imager to your LOCAL time zone (and - i.a. - "daylight saving").

For analysis-critical " time-stamps" used for and stored into JPG images we recommend to use the Filename-Time-Settings in the JPG-Image-Capturing configuration. For CMS analysis software this parameter MUST be set to "Use GMT".

Time zone: Select the "Time zone" of the location of your ASI-16 site.

Enable daylight ...: To be checked when your country uses "daylight saving".

Time synchronisation: MUST be set to "Automatic".

Automatic: Enable imager time to be synchronized with an NTP time server,.

NTP server: Internet URL or IP of a "NTP time server" accessible by the ASI-16.

Updating interval: "One hour", to try time synchronisation once per hour.

**WARNING - Local setting will get lost after each software update/restore!
Register ALL imager settings in CMS-CRM, as soon as possible!
After making any change in CMS_CRM, re-run ASI16-Installer and perform a "Configuration Data Update" or a "Full Reset"!**

6.8 JPG Image Capturing - Shooting

TOP BAR: Imager - SIDE BAR: Capture/ Shooting:

Parameters for automated capturing of JPG images. Images are uploaded immediately to a TPC/IP connected S/FTP server. - Subject and limited to settings and parameters, as soon as there is no access to the S/FTP storage server (LAN/ WAN/ Server down), if possible images are temporarily stored on a built in backup memory, and are uploaded with low priority, step-by-step, as soon as the storage server can be accessed, again.

CMS 24029 - ADV ML01 - Styria Site #4 (/6)

Home **Imager** System Help Language About

Imager > Capture > Shooting

Imager
Capture
Shooting
Streaming
Storage
Peripherals

General

Active

E-Mail Slot: Try to use one of the pre-defined

Time Slot 1: "Templates", and select preferred Template in CMS-CRM.

Active

Template: 25 CMV continuous 15sec

Interval: 15 sec

WARNING: In case of network problems images may get lost! CF/SJ backup function is ensured for minute-intervals, only!

Start: zenith 90 AM [dd.dddd*] - 30 [min]

Stop: zenith 90 PM [dd.dddd*] - 30 [min]

Imaging Parameters: CMS Standard

Picture Resolution: 1536x1536

Relative Exposure: 0

Filename Timestamp: Use GMT/UTC Use local time

Timestamp Format: Use hh:mm:00 Use hh:mm:ss

WARNING: This setting is NOT supported by CMS "FindClouds" software. To be used with new CMS "FCT-19 FindClouds Trinity" software, only.

Image Shot 1

File Postfix: 1' Relative Exposure: 0 Delay: 0 sec

Add Shot

Add Slot

18504

Rese: Save

Scheduler configuration when and how to store JPG images to a file server.

Active: Set "General/ Active" and "Time Slot1/ Active" to enable JPG image storage.

E-Mail Slot: Not fully implemented! -To send JPG's to an email account.

Time Slot 1 (2, ...):

One (or more, up to three) sets of predefined parameters, to capture one, typically two, or up to four JPG images within defined time intervals.

Name: To identify different "Time Slots". The first "time slot" must be "Standard".

Template: Select one (out of total 9) pre-defined shooting configurations.
Templates have been defined based on wishes from multiple clients.
So, most likely one of the templates also will fit to your requirements.
Try to use one of the templates, instead of setting your own configuration.
Do NOT use Template 11/12, as they make NO sense for ASI-16 V24!

Interval: e.g. 15 min:
A set of JPG's will be sent at e.g. 10:00, 10:15, 10:30, 10.45, ...

Start [Zenith]: First JPG image set will be captured at/after sunrise (= zenith/ 90° AM).

Stop [Zenith]: Last JPG image set will be captured before/at sunset (= zenith/ 90° PM).

Zenith Ang.: Recommended default value: 90° == Astronomical sunrise / sunset.
Values < 90°: Some time AFTER sunrise, some time BEFORE sunset.
The time delay varies depending on the location and the day-of-year!
>> 80° in Central Europe and April means a delay of about 1 h 15 min.
DO NOT use Zenith angles values above > 90° or below < 60°!

Pre/post Zenith Time correction: Through the [+/-] parameters you can modify the scheduler, to start/stop capturing up to 1 hour before/after sunrise/sunset time.

Capturing will be done at the per-hour timeslots as defined in "intervals. If, for example, "Interval" is set to 15 min, and actual Start[Zenith] time is 06:07, then the first JPG shot of the day will be captured at 06:15, and NOT at 06:07.

"Zenith control" requires correct settings of local imager time and local GPS coordinates. It may not work for zenith angles above 90°. Minimum allowed zenith angle depends on GPS coordinates and day-of-year. For further details please refer to side documents.

When changing from "zenith" to "time", you can enter fixed start/stop times.

Imager parameters: "CMS Standard". Not to be changed, for CMS software.

Picture resolution: Select resolution for higher or lower quality and JPG file size.

Relative exposure: NOT TO BE USE any more with new ASI-16/51+ or ASI-16/11+.
New generation ASI imager heads use advanced built-in "Wide Dynamic Range" (WDR) algorithms. Therefore change of exposure makes no practical sense, not anymore.

Filename / Timestamp / Format: Parameters to manage automatically generated JPG filenames. - Must NOT be changed when using CMS FCT cloud analysis software!

Image Shot 1/2/...:

Configuration of one or more images to be captured within the respective "Time Slot".

Delay: Relative delay, especially for a 2nd / 3rd shot within one time slot.

NOTICE: Capturing of each individual image will take about 5-10 seconds, because of processing time. Therefore the actual file-time for the first image will 5-10 seconds past

"time interval" time. Additional images will be further delayed by additional 5-10 seconds for each image within one "Time Slot". - Please consider, when setting "interval" to 15 seconds maybe sometimes a second image might get lost.

6.8.1 Template #11 and #12: For first-generation ASI-16 (V2015, V2018) only!

To be used with ASI-16/50, ASI-16/10 (V2015), ASI-16/51, and ASI-1611 (V2018). Includes dual-image shooting packages with changing exposure levels. - Changing exposure levels does not make sense for ASI systems after V2018, as all new version ASI-16 imagers use a built-in advanced wide-dynamic-range (WDR-PRO) algorithms.

6.8.2 Template #21 - V24: For standard "Cloudiness Analysis":

Single image shooting, shooting intervals ... 15 min, 10 min 5 min, or 1 min.

6.8.3 Template #25 for continuous "Cloud Movement Analysis":

"Cloud Movement Analysis" requires images with a time interval of 10-30 seconds. By experience 15 seconds is the best solution for both fast and slow moving clouds.

NOTICE: Will create huge amount of data, therefore requires large storage capacity. We recommend to move data from primary storage to a backup storage, once a month.

6.8.4 Template #26 for "Cloud Movement Analysis" each 10 Minutes:

This config includes three (3) shots with 15sec delay in one 10min interval time slot.

"Cloud Movement Analysis" requires images with a time interval of 10-30 seconds. By experience 15 seconds is the best solution for both fast and slow moving clouds.

Three shots increase probability to get at least one valid set of movement vector data.

6.9 Network Storage Settings for JPG (FTP, NAS, FileShare)

TOP BAR: Imager - SIDE BAR: Storage/ Server Settings:

Captured JPG images will be sent automatically to one (or two) FTP "Network Storage".

The screenshot displays the 'Data Storage Server' configuration page in the CMS 24029 - ADV ML01 - Styria Site #4 (/6) web interface. The interface includes a top navigation bar with 'Home', 'Imager', 'System', 'Help', 'Language', and 'About'. A left sidebar contains 'Imager', 'Capture', 'Storage', 'Data Storage Server', 'Backup Settings', 'Backup Management', and 'Peripherals'. The main content area is titled 'Imager > Backup Settings > Data Storage Server' and shows two server configuration sections.

Server 1 Configuration:

- Current status:** Data Storage Status: online
- Server settings:**
 - Server type:** FTP(S)
 - Server address:** ftp.schreder-cms.com
 - Server port:** 21
 - User name:** 90002
 - Password:** [Redacted]
 - FTP folder name:** /asi16_data
 - Passive mode
 - SFTP
 - Test** button

Enable 2nd. server: As Mirror ▾

Server 2 Configuration:

- Current status:** Data Storage Status: online
- Server settings:**
 - Server type:** FTP(S), SFTP
 - Server address:** ftp2.gapaconsulting.at
 - Server port:** 64735
 - User name:** gpapst
 - SFTP folder name:** CMS-FTP/intra/asi16_data
 - Authentication type:** Password, Public/private key
 - Password:** [Redacted]
 - Test** button

Use Encryption (FTPS instead of FTP), if available

Reset **Save server**

16504

The Network Storage (= FTP-server) IP/URL and corresponding login data.

For testing and initial operation you may use the FTP server provided by CMS. Later on you may change to an FTP server of your company. When using the CMS FTP service, you MUST NOT change the pre-defined LI/PW settings!

NOTICE:

After a Software "RESTORE" via ASI16-Installer the Server Settings will be reset to the FTP account data stored in CMS-CRM! -

Button "Test":

To check and verify if the Storage Server can be accessed via the entered settings.

Use the "Test" button BEFORE permanently save settings via "Save server".

With "Test" the Imager will try to send a "test.txt" file to the root of the storage.

A second browser window will pop up and will indicate if the test transmission was successful, or if it failed. If failed, then recheck the settings (IP/URL, LI/PW, ...), and check if the storage is online and can be accessed. Take care of the folder formats used.

Second FTP server: If activated, ASI will support two independent FTP servers.

"Mirror": Data are always sent to BOTH FTP servers, at the same time.

"Fall-back": Data are sent to 2nd FTP only if 1st FTP server is online.

... Backup: Backup Memory will be activate if BOTH FTP are offline.
Backup data are uploaded to first FTP getting online again.

6.10 Backup Storage (Temporary Storage on Flash Memory)

TOP BAR: Imager - SIDE BAR: Storage/ Backup Setting:

In case of a temporary problem with the online "Network Storage" access, like router down or network down or WAN down or storage server down, ASI-16 will temporarily store JPG's within the imager. Later on, as soon as the "Network Storage" is back online for a reasonable time, ASI-16 will transfer temporarily stored images to the network storage.

The low-priority process of sending "backup images" will be merged into the more important high-priority process of capturing and sending "new images". Therefore sending all backup images may take some time, depending on the quantity. Multiple connection breakdowns during the recovery process may eventually cause loss of some images.

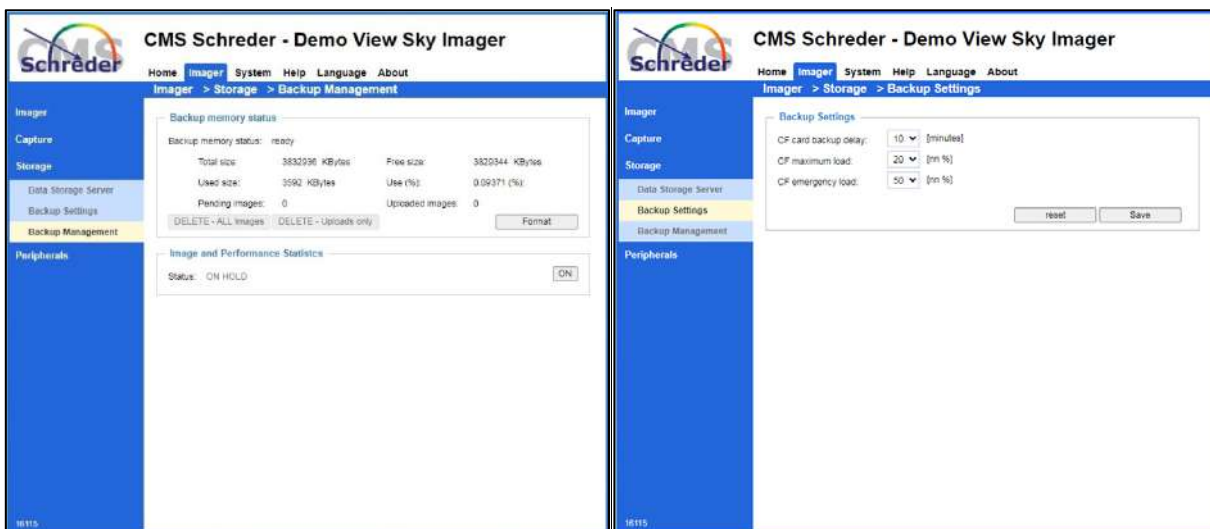

Backup delay: Initially data are stored in a non-remanent RAM memory.
After the delay time data are moved to a remanent CF-memory.
In case of a power-down within this period RAM data will be lost.

Maximum load: Usually all data, even if marked as transferred, will be kept;
If this parameter exceeded, transferred data will be deleted;

Emergency load: If this parameter exceeded, a part of "older data" are deleted,
till the CF memory has reached a free capacity of about 50%..
Means: Some "old data" will be lost, newer data will survive.

ADVICE NOTICE: Regularly check "Backup Storage" status, about once each month!
Each month, upon regular check, click "DELETE - Uploaded Only".
Each three (3) months, click on "Format" and wait > 10 minutes.
After "Format" completed, power-off, wait >1 min., and power-on!

6.11 Peripherals Controller (PeriCon Settings, Data Logger)

TOP BAR: Imager - SIDE BAR: Peripherals / General:

Please refer to Section 7ff, for detailed hardware and software descriptions.

Below screenshot shows a special bug-case scenario (defective T/RH sensor).



CMS/Gepa Styria Test/Demo Site 3 (I3)

Home **Imager** System Help Language About

Imager > Peripherals > Peripherals

Imager

Capture

Storage

Peripherals

General

Pyranometer

Peripherals

Peripherals SW: 2012295

Temperature: 999.9 °C

Rel. Humidity: 999 %

Dew Point: 999 °C

"999" --> T/RH Sensor not connected or defective.

Fan Status: ON

Heater Status: OFF

Sensor Status: ERR

Basic Settings

Heater Threshold: 15 °C

Dewpoint Threshold: 5 °C

Datalogger Interval: 15 sec

Reset

Save

Advanced Settings

Datating Type: Standard

Irradiance 1-sec Mode: NO

Reset

Save

"STAT=2..9.."; --> "9" indicates "ERROR".
... Fan, Heater, T/RH sensor, Pyranometer

Logs

```
SQNR=60975;DATE=23-07-24;TIME=16:56:19;STAT=201912;TMPA=999;TMPP=9999;TMPB=25;TMPC=29;RHUA=999;DWPA=999;PTYPA=1;PNAME=NS-805;PIRA=102;PIRP=102;PIRN=102;PIRL=78;PIRH=483;
SQNR=60990;DATE=23-07-24;TIME=16:56:30;STAT=201912;TMPA=999;TMPP=9999;TMPB=25;TMPC=29;RHUA=999;DWPA=999;PTYPA=1;PNAME=NS-805;PIRA=102;PIRP=102;PIRN=102;PIRL=78;PIRH=483;
SQNR=61005;DATE=23-07-24;TIME=16:56:45;STAT=201912;TMPA=999;TMPP=9999;TMPB=25;TMPC=29;RHUA=999;DWPA=999;PTYPA=1;PNAME=NS-805;PIRA=102;PIRP=102;PIRN=102;PIRL=78;PIRH=483;
SQNR=61020;DATE=23-07-24;TIME=16:57:00;STAT=201912;TMPA=999;TMPP=9999;TMPB=25;TMPC=29;RHUA=999;DWPA=999;PTYPA=1;PNAME=NS-805;PIRA=102;PIRP=102;PIRN=102;PIRL=78;PIRH=483;
SQNR=61035;DATE=23-07-24;TIME=16:57:15;STAT=201912;TMPA=999;TMPP=9999;TMPB=25;TMPC=29;RHUA=999;DWPA=999;PTYPA=1;PNAME=NS-805;PIRA=102;PIRP=102;PIRN=102;PIRL=78;PIRH=483;
SQNR=61050;DATE=23-07-24;TIME=16:57:30;STAT=201912;TMPA=999;TMPP=9999;TMPB=25;TMPC=29;RHUA=999;DWPA=999;PTYPA=1;PNAME=NS-805;PIRA=103;PIRP=102;PIRN=102;PIRL=78;PIRH=483;
SQNR=61065;DATE=23-07-24;TIME=16:57:45;STAT=201912;TMPA=999;TMPP=9999;TMPB=25;TMPC=29;RHUA=999;DWPA=999;PTYPA=1;PNAME=NS-805;PIRA=104;PIRP=103;PIRN=103;PIRL=78;PIRH=483;
SQNR=61080;DATE=23-07-24;TIME=16:58:00;STAT=201912;TMPA=999;TMPP=9999;TMPB=25;TMPC=29;RHUA=999;DWPA=999;PTYPA=1;PNAME=NS-805;PIRA=105;PIRP=104;PIRN=103;PIRL=78;PIRH=483;
SQNR=61095;DATE=23-07-24;TIME=16:58:15;STAT=201912;TMPA=999;TMPP=9999;TMPB=25;TMPC=29;RHUA=999;DWPA=999;PTYPA=1;PNAME=NS-805;PIRA=105;PIRP=105;PIRN=104;PIRL=78;PIRH=483;
SQNR=61110;DATE=23-07-24;TIME=16:58:30;STAT=201912;TMPA=999;TMPP=9999;TMPB=25;TMPC=29;RHUA=999;DWPA=999;PTYPA=1;PNAME=NS-805;PIRA=105;PIRP=105;PIRN=105;PIRL=78;PIRH=483;
SQNR=61140;DATE=23-07-24;TIME=16:59:00;STAT=201912;TMPA=999;TMPP=9999;TMPB=25;TMPC=29;RHUA=999;DWPA=999;PTYPA=1;PNAME=NS-805;PIRA=106;PIRP=106;PIRN=105;PIRL=78;PIRH=483;
```

Freeze Run

Upload Log | Download Log

Command

Send command: [input field]

6.12 Networking - CMS DDNS (Dynamic Domain-Name) and VPN

TOP BAR: System - SIDE BAR: Network / DDNS - HTTP:

For customers which do not have a fixed (static) WAN IP, or which do not want to formally disclose this fixed static IP, CMS provides a free of charge non-public DDNS-Service. If enabled, ASI-software automatically synchronizes its WAN IP with CMS-DDNS-Server, and CMS-Server will publish the auto-generated URL based on the ASI serial number.

The screenshot shows the CMS web interface for 'CMS - Kirchbichl Station #2/3'. The navigation bar includes 'Home', 'Imager', 'System', 'Help', 'Language', and 'About'. The breadcrumb trail is 'System > Network > DDNS / VPN - HTTP'. The left sidebar has 'Network type', 'Security', and 'Service' sections. The main content area is titled 'DDNS / VPN - HTTP' and contains the following configuration options:

- HTTP port:** 80 (For local network browser use)
- Secondary HTTP port:** 8080 (For remote / DDNS browser use)
- Enable CMS DDNS**
ASI Manager URL:
To enable CMS DDNS, open port 8080 on your router and forward it to this ASI IP. For own defined port numbers (multiple ASI, ...) setup "port translation" on your router. Advice: For convenience, register own defined port numbers at CMS-CRM imager sites.
- Enable CMS Remote-Connection**
Status: connected
Web-Browser URL:
This will connect the imager with the CMS Schreder remote connection server to make it public available without need to change your router settings. Please take note that it can take a few minutes until the external URL is available.
- Enable public DDNS**

Buttons for 'Reset' and 'Save' are located at the bottom right of the configuration area. The bottom left corner of the page shows the number '16508'.

- Secondary Port:** Must be "8080" if your want to run online-updates via Internet. For access via Internet, setup a router rule for port forwarding. In case of multiple ASI within the same LAN, use port translation.
- Enable ... DDNS:** Please check, if you want to use this CMS-DDNS internet service. **WARNING:** If checked, ASI will send messages to the CMS server.
- Enable ... Remote:** Available with ASI-16 V24 (Serial >= #16501). When activated, ASI-16 establishes an encrypted tunnel between ASI-Imager and CMS-Schreder CRM-Server. Then a remote user or CMS support can securely access the ASI via the HTTPS-URL as provided and shown in CMS-CRM for this specific ASI imager.

6.13 Security Settings - User Accounts - Name/Password

TOP BAR: System - SIDE BAR: Security/UserAccount:

Each ASI comes with a pre-defined set of User/Password LogIn's, stored in CMS-CRM.

Most important: Your personal CMS "Customer" LI/PW, based on your account ID.
It can be used at any time, at delivery or after any update/restore.

Also, up to you: Your personal LI/PW, as defined by you via the CRM account.
It can be used after entry at CRM and the next update/restore.
Please enter secondary password in CRM, and run "update".

WARNING - Local security Data are lost after each software update/restore

The ASI Web-GUI allows to (temporarily) enter new users with passwords, and/or allows to (temporarily) change user names and passwords and rights. ALL THOSE CHANGES WILL BE LOST after any "software restore" and/or "software update", for example by using the ASI16-Installer tool. - Please take carefully note of Network Settings and Security Data before and software update or restore, or total imager reset! - Use CMS-CRM to setup permanently available Username/Password sets.

6.14 Security Settings - User Accounts - HTTPS

TOP BAR: System - SIDE BAR: Security/HTTPS:

To activate HTTP/S connection protocol. Requires a trustful "SSH Certificate".

WARNING: Do NOT immediately deactivate standard HTTP protocol, without proper testing of a new HTTPS configuration in parallel. A mistake in the HTTPS configuration will fully block access to the ASI, which then requires a complicated low-level hardware reset!

6.15 Security Settings - User Accounts - Name/Password

TOP BAR: System - SIDE BAR: Security/Firewall:

To manage access to this ASI, by blocking or opening specific IP's or IP ranges.

WARNING: Mistakes in this configuration may fully block access to this ASI!

6.16 Service - Maintenance (Reboot, PeriCon Firmware Update)

TOP BAR: System - SIDE BAR: Maintenance:

The screenshot displays the CMS web interface for Kirchbichl Station #2/3. The top navigation bar includes 'Home', 'Imager', 'System', 'Help', 'Language', and 'About'. The breadcrumb trail is 'System > Service > Maintenance'. The left sidebar contains 'Network type', 'Security', 'Service', and 'Maintenance' (highlighted). The main content area is divided into several sections:

- System Configuration:** ASI Main Type: ASI-16/15 BASIC V2024, MAC-ID: 0002D1A9ADA7, Imager HW/FW: FE9382_v2-VVTK-1.2001.34.01h, SW Ver: 2411082.
- FCT Eval - Live Data:** Interval: 1 min, Time zone: local, Keep for min: 30 min. Includes a 'Set' button.
- Export files:** Export configuration file and Export server status report, each with an 'Export' button.
- Image Calibration:** Image Center Position - X-Axis: 976, Y-Axis: 1000. Includes 'Start Calibration' and 'Reset to Defaults' buttons. A warning states: 'WARNING: Do NOT calibrate without needs! Requires specially trained engineers! Before calibration, the ASI glass dome must be covered by a thin white paper tissue. The entire live image must show a relatively uniform light/medium grey surface.' RGB Gain: Red: 17, Blue: 5, Saturation: 30. Includes a 'Set' button.
- Image Quality:** Fixed quality: Excellent, Framerate: 10 Mbps. Includes a 'Set' button.
- Ethernet Adapter Service:** Activate ETH adapter auto-reset: , Activate ETH/WAN status logging: , Activate NTP time check and sync: , Interval: 15 min. Includes a 'Set' button.
- Available Logs:** [show/hide full list](#). List of dates: 2024-11-12, 2024-11-11, 2024-11-10, 2024-11-09, 2024-11-08. Includes links for 'Download all', 'Remove >7 days', 'Remove all', and 'Reload'.
- Reboot:** Reboot the device. Includes a 'Reboot' button.

18508

- System Configuration: Data about ASI imager head hardware and software.
- Peripheral Controller: Data about Peripheral Controller hardware and software.
- Export configuration file: Generate a backup of a part of local configurations
- Export server ... report: Generate a package to help analyse problems or bugs. Please send this package to CMS support, via Email.

Image Calibration: Tools for testing and calibration by CMS, only!
CMS has already optimized settings before delivery.
Approved data are stored in/ taken from CMS-CRM.

Image Quality: To select JPG compression level and network bandwidth limit.
As "better" setting, as better image quality, but as larger file size.
For FCT cloud analysis software we recommend to use "good".

Ethernet Adapter Service: Functions to check and auto-fix some client LAN issues.

... ETH auto-reset: Unmounts and re-mounts the ASI Ethernet interface [15] minutes
after FTP-Server or NTP-Server could not be accessed via LAN.
Fixes issues where a less stable DHCP server does not re-establish
connection after power-down or other network related problems.

... ETH ... logging: Logs LAN/WAN connectivity, to identify issues in client's network.

... NTP ... sync: Check stability of client's NTP server, and re-sync time if necessary.

... Interval: Time Interval for all "Ethernet Adapter Services" and log entries.

... Available logs: To download and/or delete one or more "ETH Service" log files.

Reboot: To reboot the ASI imager. - May take up to 5 minutes.

Example of "Ethernet Adapter Service" log file:

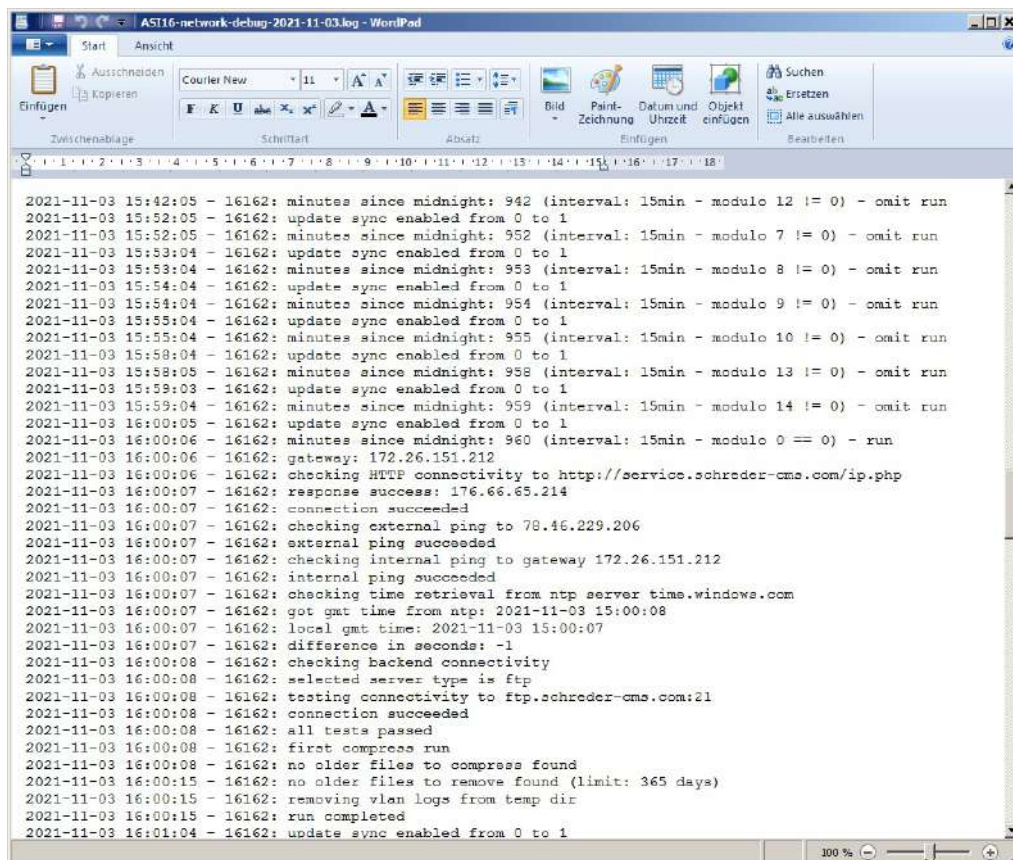

```
2021-11-03 15:42:05 - 16162: minutes since midnight: 942 (interval: 15min - modulo 12 != 0) - omit run
2021-11-03 15:52:05 - 16162: update sync enabled from 0 to 1
2021-11-03 15:52:05 - 16162: minutes since midnight: 952 (interval: 15min - modulo 7 != 0) - omit run
2021-11-03 15:53:04 - 16162: update sync enabled from 0 to 1
2021-11-03 15:53:04 - 16162: minutes since midnight: 953 (interval: 15min - modulo 8 != 0) - omit run
2021-11-03 15:54:04 - 16162: update sync enabled from 0 to 1
2021-11-03 15:54:04 - 16162: minutes since midnight: 954 (interval: 15min - modulo 9 != 0) - omit run
2021-11-03 15:55:04 - 16162: update sync enabled from 0 to 1
2021-11-03 15:55:04 - 16162: minutes since midnight: 955 (interval: 15min - modulo 10 != 0) - omit run
2021-11-03 15:58:04 - 16162: update sync enabled from 0 to 1
2021-11-03 15:58:05 - 16162: minutes since midnight: 958 (interval: 15min - modulo 13 != 0) - omit run
2021-11-03 15:59:03 - 16162: update sync enabled from 0 to 1
2021-11-03 15:59:04 - 16162: minutes since midnight: 959 (interval: 15min - modulo 14 != 0) - omit run
2021-11-03 16:00:05 - 16162: update sync enabled from 0 to 1
2021-11-03 16:00:06 - 16162: minutes since midnight: 960 (interval: 15min - modulo 0 == 0) - run
2021-11-03 16:00:06 - 16162: gateway: 172.26.151.212
2021-11-03 16:00:06 - 16162: checking HTTP connectivity to http://service.schreder-cms.com/ip.php
2021-11-03 16:00:07 - 16162: response success: 176.66.65.214
2021-11-03 16:00:07 - 16162: connection succeeded
2021-11-03 16:00:07 - 16162: checking external ping to 78.46.229.206
2021-11-03 16:00:07 - 16162: external ping succeeded
2021-11-03 16:00:07 - 16162: checking internal ping to gateway 172.26.151.212
2021-11-03 16:00:07 - 16162: internal ping succeeded
2021-11-03 16:00:07 - 16162: checking time retrieval from ntp server time.windows.com
2021-11-03 16:00:07 - 16162: got gmt time from ntp: 2021-11-03 15:00:08
2021-11-03 16:00:07 - 16162: local gmt time: 2021-11-03 15:00:07
2021-11-03 16:00:07 - 16162: difference in seconds: -1
2021-11-03 16:00:08 - 16162: checking backend connectivity
2021-11-03 16:00:08 - 16162: selected server type is ftp
2021-11-03 16:00:08 - 16162: testing connectivity to ftp.schreder-cms.com:21
2021-11-03 16:00:08 - 16162: connection succeeded
2021-11-03 16:00:08 - 16162: all tests passed
2021-11-03 16:00:08 - 16162: first compress run
2021-11-03 16:00:08 - 16162: no older files to compress found
2021-11-03 16:00:15 - 16162: no older files to remove found (limit: 365 days)
2021-11-03 16:00:15 - 16162: removing vlan logs from temp dir
2021-11-03 16:00:15 - 16162: run completed
2021-11-03 16:01:04 - 16162: update sync enabled from 0 to 1
```

7 Peripherals Controller, Hardware / Software

ASI-16/5n (Advanced) incorporates a secondary "Peripherals Controller" (PeriCont), physically and logically separated from the "Main Controller" in the imager camera head.

PeriCont Hardware is mounted in a separate box at the bottom mounting plate.

PeriCont-V2 includes additional optional features, like additional external and internal sensors, advanced heating and power management, and UC-RTC-based timing. For high precision T/RH measurements, TRH sensor now is connected via a 2m cable and mounted into a DM 12 mm stainless steel tube to allow installation into a "Radiation Shield". TRH sensor MUST be connected in any case, as otherwise the heating system will NOT work, and the ASI GUI will indicate a TRH sensor ERROR!

7.1 PeriCont - Hardware and Sensors - Summary

The "Peripheral Controller" with its independent CPU manages power- and data-distribution, multiple internal and external sensors, and controls and supervises functionality of forced ventilation (fan) and air flow heating. - An internal multi-colour LED indicates the status of all configured components connected to the PeriCont.

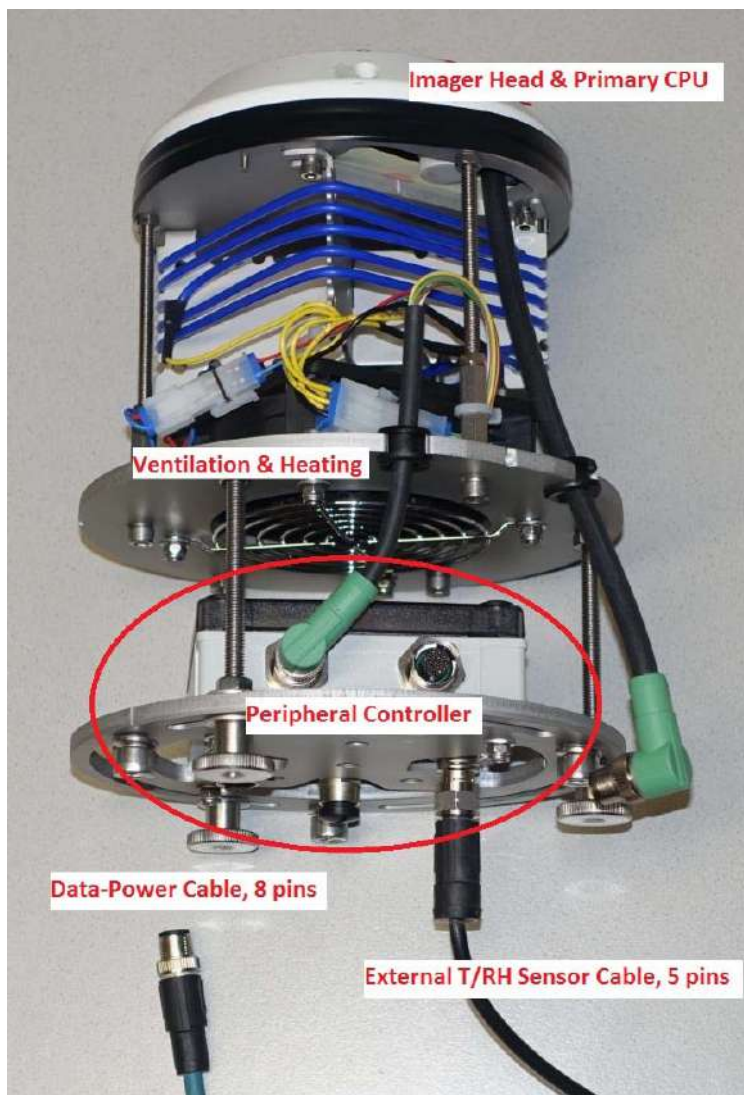

7.2 PeriCont - Hardware LED Status Signals

The multi-colour LED is mounted inside the PeriCont box, and is visible from all sides through the semi-transparent cover of the box. In bright sunlight it might be necessary to look relatively close to the ASI imager.

During "boot sequence" long signals indicate three steps. No signal or hanging in one step indicates "no power", or a defect in hardware, or a corrupted firmware. - Reboots will happen three times after "power-on", after ASI imager reboot, or during and after ASI software updates. - In "run-mode" a reboot may happen about once every hour.

After "boot" the status of internal and external modules is indicated by a SEQUENCE of long and short signals in different colours, which is repeated each about 30 seconds.

Step	Time	Colour	Meaning
Boot 1	long	White	Pre-boot check sequence.
Boot 2	long	Yellow	Internal hardware checks.
Boot 3	long	Green	Driver connectivity check.
Pause	long	dark	.-----
Run 1	long	Green	Summary: All parts OK
		Red	Summary: Some Part(s) on ERROR
Run 2	short	Blue	Ventilation (Fan): Running, OK.
		Red	Ventilation (Fan): Blocked, defective, ERR.
Run 3	short	Blue	Heating: OK, but now heating OFF.
		Yellow	Heating: Heating switched on, ON.
		Red	Heating: Defective, not connected, ERR.
Run 4	short	Green	T/RH Sensor: Connected, working, OK.
		Red	T/RH Sensor: Not connected, defective.
Run 5	short	White	Pyranometer: Not configured (CRM, ASI).
		Green	Pyranometer: Connected, working, OK
		Red	Pyrano: Not connected, defective, ERR.
Pause	long	Dark	.-----
Repeat			Repeat sequence at step "Run 1".

Watch the LED signal especially during and after (outdoor) installation.

7.3 PeriCont - ASI GUI - General Settings

TOP BAR: Imager - SIDE BAR: Peripherals / General:

CMS Schreder - Demo View Sky Imager

Home **Imager** System Help Language About

Imager > Peripherals > General

Peripherals

Peripherals SW: 2001253

Temperature:	8.2 °C	Fan Status:	ON
Rel. Humidity:	86 %	Heater Status:	ON
Dew Point:	5 °C	Sensor Status:	ON

Basic Settings

Heater Threshold: °C Datalogger Interval: sec

Dewpoint Threshold: °C

Advanced Settings

Datastrng Type: Irradiance 1-sec Mode:

Logs

```
SQNR=37498;DATE=21-11-02;TIME=10:24:58;PIRA=421;
SQNR=37499;DATE=21-11-02;TIME=10:24:59;PIRA=421;
SQNR=37500;DATE=21-11-
02;TIME=10:25:00;STAT=202222;TMPA=8;TMPP=82;TMPB=18;TMPC=21;RHUA=86;DWPA=5;PTYP=1;PNAM=MS-
80M;PIRA=421;PIRP=421;PIRM=421;PIRL=419;PIRH=421;
SQNR=37501;DATE=21-11-02;TIME=10:25:01;PIRA=421;
SQNR=37502;DATE=21-11-02;TIME=10:25:02;PIRA=421;
SQNR=37503;DATE=21-11-02;TIME=10:25:03;PIRA=421;
C-----;?
SQNR=37504;DATE=21-11-02;TIME=10:25:04;PIRA=421;
SQNR=37505;DATE=21-11-02;TIME=10:25:05;PIRA=421;
SQNR=37506;DATE=21-11-02;TIME=10:25:06;PIRA=422;
SQNR=37507;DATE=21-11-02;TIME=10:25:07;PIRA=422;
V-----; SWNR=2001253;SQNDL=37503;DATE=21-11-
02;TIME=10:25:08;THTYP=75;TTEMP=15;TDEWP=5;IUFAN=800;ILFAN=5;IUHEA=3000;PYDEF=11;PYAVT=30;PYAWW=1;PYOST
=11;MSDLY=15;FNDLY=30;OSTRG=3;DBGFL=0;ASIRE=900;DBGRE=900;MPPFL=-1;
SQNR=37508;DATE=21-11-02;TIME=10:25:08;PIRA=422;
SQNR=37509;DATE=21-11-02;TIME=10:25:09;PIRA=421;
SQNR=37510;DATE=21-11-02;TIME=10:25:10;PIRA=422;
SQNR=37511;DATE=21-11-02;TIME=10:25:11;PIRA=422;
SQNR=37512;DATE=21-11-02;TIME=10:25:12;PIRA=422;
```

[Upload Log](#) | [Download Log](#)

Command

Send command:

Peripherals: Data as delivered by the PeriCon. - Please press [F5] for refresh.
The same data also are displayed at the Imager homepage.

Temperature/ Rel. Humidity/ Dew Point: Data from the environmental T/RH sensor.

NOTICE: For high-quality temperature and humidity data the T/RH sensor MUST be installed into a professional "radiation Shield"!

Fan/ Heater/ Sensor Status: OFF / ON / ERR (ERR = Error, blocked, broken)

Settings: To managed the ON/OFF status of the heater, and datalogger data.

Heater Threshold: Minimum outdoor temperature, to switch on the heater.

Dewpoint Thr...: Minimum dewpoint deviation, to switch on the heater.

Datalogger Int...: Time interval to get PeriCont data updates from PeriCont.

Datastring Type: Amount / variety / length of (system internal) data to be logged. For debugging, set to "long" and provide the "peridata.csv" file.

Irradiance 1sec ...: To log Pyranometer data (irradiance) once every second.

Logs: Current data as received from / sent to the PeriCon "Data Logger".
All Data are stored in the "peridata.csv" file, once a day, along with images.
Important data are also stored in the JPG image "EXIF" data structure.

Command: To send special and encrypted command to PeriCon;
(Commands and encryption code upon special request).

7.4 PeriCont - ASI GUI - Pyranometer Configuration / Data

TOP BAR: Imager - SIDE BAR: Peripherals / Pyrano:

CMS Schreder - Styria Site #3 (/3)

Home Imager System Help Language About

Imager > Peripherals > Pyranometer

Attached Pyranometer

CFG Type: 20 - EKO, MS-80S Connection status: online
 Change RSP Type: 0 - MS-80S

Parameters

Averaging Time (Period): 30 sec Extended Data Request: Once in 1h
 Averaging Weight Factor: 1 cnt GTI - Tilt Correction: 0
 Reset Save

Tilt Calibration (MS-S only)

Tilt (X-Axis) ✓
Raw value: -0.4°

Roll (Y-Axis) ✗
Raw value: 1.6°

Irradiance Data - Extended Sensor Data

GHI - Latest Value	1 W/m ²	Minimum / Period	0 W/m ²
Average - Packaged	0 W/m ²	Maximum / Period	1 W/m ²
Average - Moving	1 W/m ²	Pyrano Rel. Humidity	23 %
Pyrano Temperature	23 °C	Tilt Sensor Y-Axis	1.6 Deg
Tilt Sensor X-Axis	-0.4 Deg	Pyrano SNR	190475032

16162

Attached Pyranometer:

CFG Type: The type of Pyranometer configured at this moment:

RSP Type: RSP Type: Pyranometer type, as reported from device via ModBus.

Change: To change the type of Pyranometer, mainly for trial purpose.
For permanent storage, please also update settings in CRM.
CFG type MUST match with actually installed Pyrano hardware.
After change of setting ASI must be power-OFF for 15 seconds.

Parameters:

Internally, PeriCont collects irradiance data once every second, even if not sent to the ASI datalogger. Within each "Averaging Period" PeriCont internally calculates averages, minimum and maximum, and sends it to the datalogger within each "logging period".

Averaging Period: Timeframe for averages, minimum and maximum.

Weight Factor: Set a dynamic priority for "newer" data above "older" data.
Applicable for "moving average", only.

Ext Data Requ.: Interval to send less-important data to the datalogger.
E.g. Pyrano serial number, internal temperature and tilt.

GTI -Tilt correct.: To adjust tilt calibration for GTI (Global Tilted Irradiance).
Frequently used in solar power (PV) applications.

Tilt Calibration: To assist proper mechanical levelling of Pyranometer.
Available only for EKO Pyranometers Type "MS-80S".
Levelling should be within +/- 1° in both axes (X/X).

7.5 Datalogger File - Datafield Codes - Command Codes

ASI-GUI ./Imager/Peripherals/General contains a "Log-Frame" showing the last few minutes of communication between "PeriCont Controller" and "ASI Imager Head".

Entire communication is stored into a "peridata_16snr_yymmdd.csv" File, one file per days, sent to the network-storage-place, into corresponding day-date-folders along with JPG images. The file at the network storage place is updated once per hour, a few seconds after the full hour. Because of its special structure, this "Peridata.CSV" cannot be directly used for imports into SQL databases or XLS sheets. For such use, CMS provides a "Peridata Converter Tool", which can be downloaded from CMS-CRM/Downloads. The tool automatically generates table-style CSV files. See Sections below

Description of Dataset Identifiers and Command Codes:

RX: SQNR Dataset: Sequence ID, "PeriCont Controller" --> "Imager Head":
SQNR=57326; Time stamp, seconds after midnight, synced to ASI time;;
The timestamp is INVALID for about 3 minutes after reboot;

**) DATE=19-09-01 Real time clock DATE, Format: "yy-mm-dd"

**) TIME=18.55:44 Real time clock TIME, Format: "hh:mm:ss"

STAT=201222; Hardware status flags; Format "STAT=mlkjih";

h = Fan Status, h= Stat * 1;

i = Heater Status, i= Stat * 10;

j = T/RH Sensor Status, j = Stat * 100;

k = Pyranometer Sensor Status, k =Stat * 1000

l = "0", reserved for future hardware extension;

Z=0: "---", does not exist; LED= "Dark"

Z=1: "OFF", OK but switched off; LED= "Green" or "Blue";

Z=2: "ON", switched on; LED= "Blue" or "Yellow";

Z=9: "ERR", defect (shortcut, blocked, broken ...); LED "Red";

m = Version of PeriCont Communication Protocol:

1= 2016-01 till 2017-12

2 = 2018-01 till today, including Pyranometer and RTC;

Examples: 202222 = Fan ON, Heater ON, TRH Sensor OK; Pyrano ON/OK;
209212 = Fan ON, Heater OFF, TRH Sensor OK; Pyrano ERROR;
200219 = Fan ERR, Heater OFF, Sensor ON, Pyrano not defined;
200912 = Fan ON, Heater OFF, TRH Sensor defect or not connected;

TMPA=5; Outdoor Temperature, by environmental sensor;

TMPP=50; Outdoor Temperature, by env. sensor, as 0.1°C value;

*) TMPB=19; Temperature near the air heating coil;

*) TMPC=16; Temperature inside the imager (camera) head;

RHUA=65; Outdoor Relative Humidity, by environmental sensor;

UINA=48; Primary Input Voltage (HPoE line entry point)

- IFAN=204; Fan sensing current, Fan is ON (mA);
IHEA=1251; Heater current, Heater is ON (mA);
PI..=654; Pyranometer data, Irradiance in W/m2
+) PIRA=654; Non-averaged value of one second ago measurement;
+) PIRP=654; "Packaged Average" over averaging period;
+) PIRM=654; "Moving Average" over averaging period;
+) PIRL=650; Minimum, lowest value within last averaging period;
+) PIRH=660; Maximum, highest value within last averaging period;
- RX: V----- Parameter Dataset: From "Pericont Controller" to "Imager Head":
- SWVNR=160815; Software version of PeriCon Firmware;
TTEMP=15; Threshold temperature for heater control;
TDEWP=5; Threshold dewpoint diff. temperature, heater control;
UFAN=500; Upper limit (blocked) for fan current (mA);
ILFAN=5; Lower limit (broken) for fan current (mA);
IUHEA=3000; Upper limit (shortcut) for heater current (mA);
MSDLY=15; Message delay, time between messages (sec);
FNDLY=30; Fan delay time, retry to start after "Error" (sec);
SFLAG=30; Status-Flag time, update interval status flags (sec);
OSTRG=3; Output string format; 1=short; 3= standard; 5=long;
DBGRE=0; Debug-Flag, watchdog time; CMS internal use only;
...
+) PYDEF=15; Pyranometer definition; brand, type, ...;
+) PYAVT=30; Pyrano Averaging Time; Seconds;
+) PYAVW=1; Pyrano Weighting Factor for Moving Average;
- TX: Command - from "Imager Head" to "PeriCont Controller":
- B15 Command to set TTEMP to 15°C;
C5 Command to set TDEWP to 5%;
I15 Command to set MSDLY to 15 seconds;
... Additional commands are hidden (not displayed);
- *) Data available with 2nd and later generation ASI hardware / Firmware.
Second generation ASI hardware starts with SN 16020, and higher.
- ***) Data available with 3rd and later generation ASI PeriCont firmware, only.
Firmware update possible via special cable + PC software, or ASI GUI.
- +) Available only when having purchased the "Pyranometer Modbus" Option.
At the moment ASI-16/52 supports EKO pyranometers with Modbus Interface.
ASI-16/51: Later purchase and upgrade possible. No new hardware needed.
ASI-16/52: Hardware upgrade possible by replacing PeriCont controller device.

7.6 "PeriDatConv---.jar" - Peripheral Data Converter Tool

Download the "PeriData Converter Tool" from CMS-CRM, download site.

This tool (semi-automatically) converts raw "peridata_16snr_yymmdd.csv" files into table-structured "peridata_16snr_yymmdd_tab.csv" files. Storage locations for raw data and converted data can be selected in the "Configuration Section". When using multiple storage locations for multiple "sites", the user can create and store multiple "profiles". The Configurator automatically detect if the "raw data" root directory contains one or multiple ASI imagers, one ASI imager only, or a "single day" directory. We strongly recommend to allocate the raw data root to the ASI default root "/asi16_data/".

8 ASI-16/5n - Mechanical Installation Guide

8.1 ASI-16/5n Imager - Sample Mast-Mount Designs



8.2 Preparation for Mounting

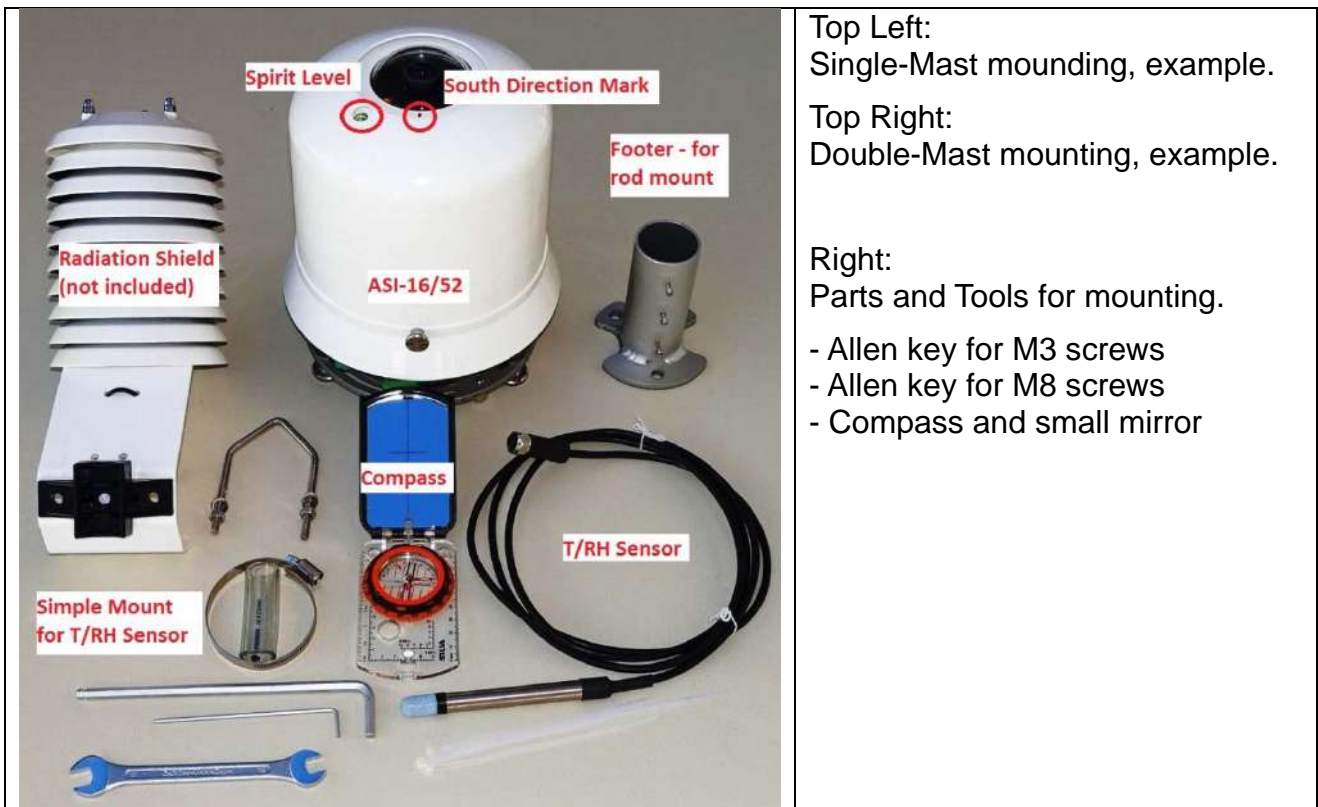

8.3 Step-by-step Mounting Guide

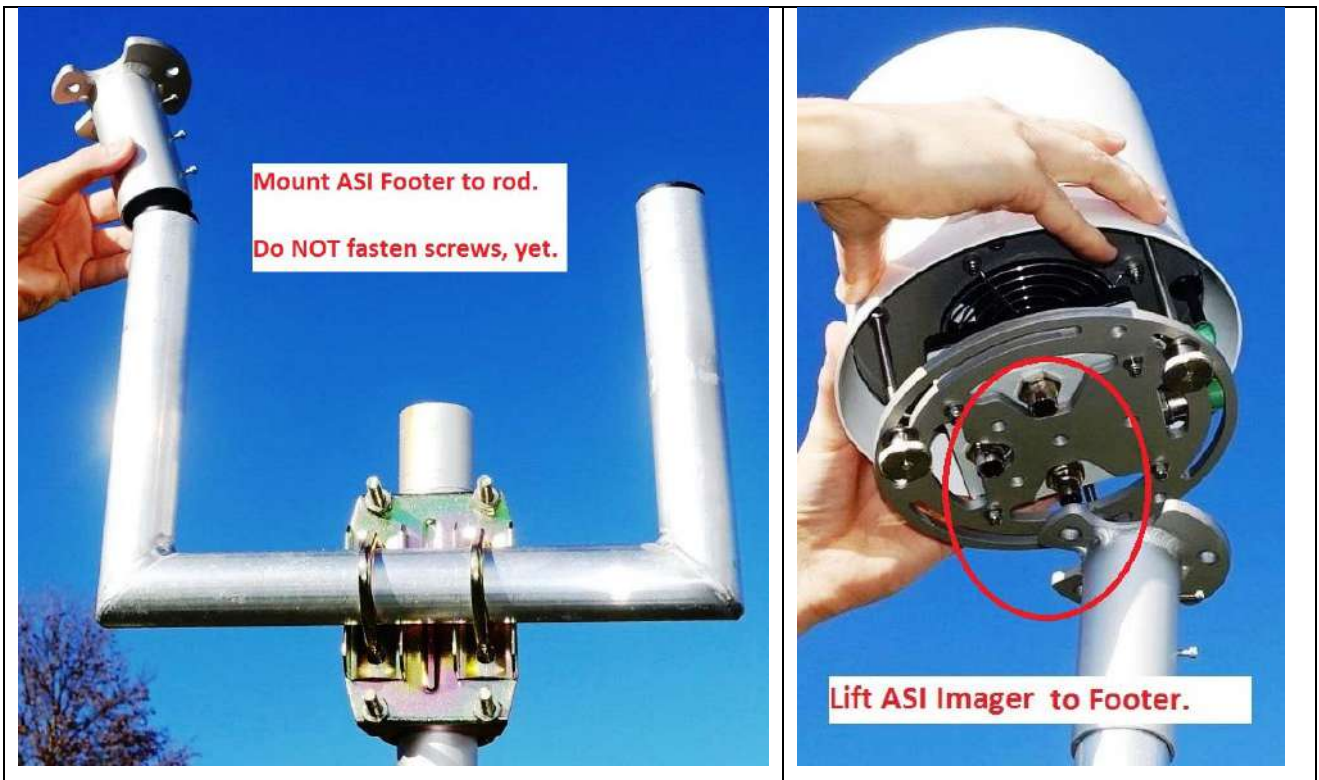



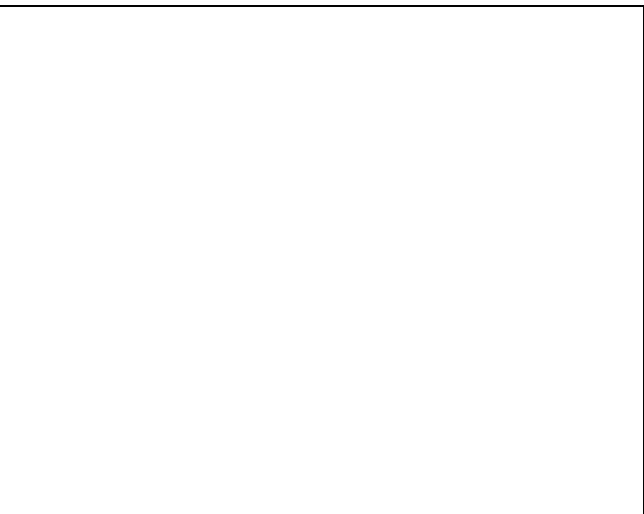

	<p>WARNING:</p> <p>The CMS HPOE Injector and the AC/DC Power Supply must be installed in a dry and safe place without the risk of exposure to water or strong (condensing) humidity!</p>
<p>Electrical connection (inside building):</p> <ol style="list-style-type: none"> 1. Connect HPOE cable to CMS injector. 2. Connect power supply to injector. 3. Connect router LAN cable to injector. 4. Connect power supply to AC power. 	<p>Check basic electrical operation:</p> <p>Check imager controller box for illuminated LED(s). Colour and number of LEDs vary, depending of ASI-16 release version. At least one LED must be illuminated.</p>

9 Pyranometer Option - Hardware Installation Guide

9.1 Pyrano Mounting - Components

Pyranometer Option delivery includes the "Pyrano Mounting Arm" and the ModCable. It does NOT include the Pyranometer itself. An ASI qualified pyranometer can be ordered separately via your local agent, via EKO-Europe or via CMS-SchrederCMS



ASI-16/5nn"Pyranometer Mounting Arm" comes with two non-pre-assembled mounting arm components, and small additional parts (screws, washers) for assembly and mounting the arm onto the ASI body.

Screws to mount the Pyranometer itself are NOT included. Usual those screws are a part of the Pyranometer supplier scope of supply.

9.2 Mounting the Pyrano Mounting Arm to an ASI-16/5n

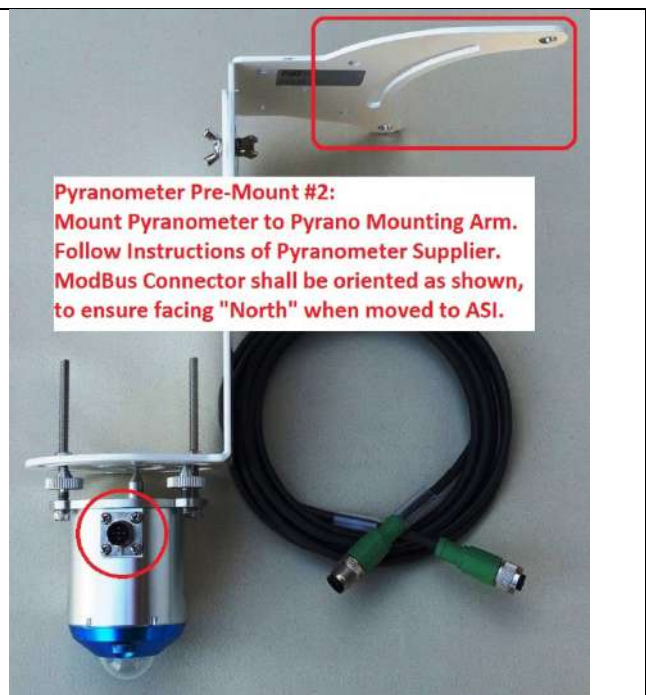



When mounting the Pyranometer, consider Northern or Southern hemisphere.

The plug and cable always shall face "away from sun", to avoid heat by exposure to direct sun



Remove two (of the three) Hand Screws. Check pic which 2 Screws to be removed.

Insert Mounting Arm into the Screws. Reattach Hand Screws, but dont fasten.

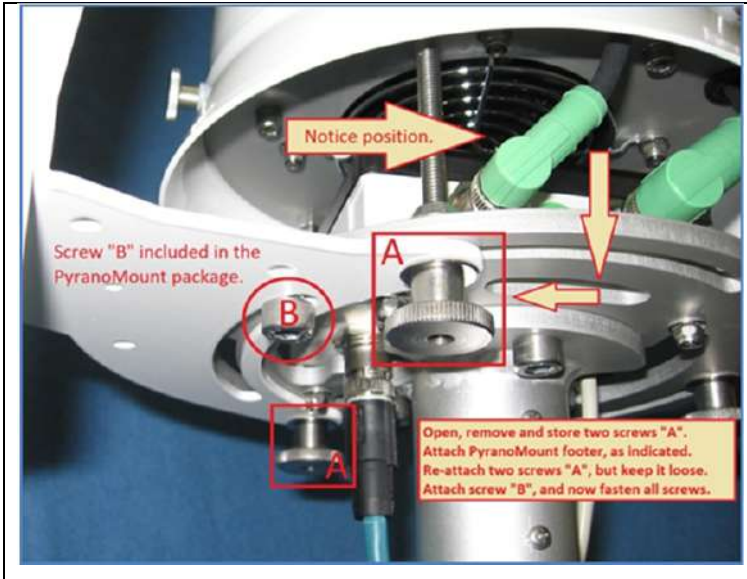

Notice position.

Screw "B" included in the PyranoMount package.

Open, remove and store two screws "A". Attach PyranoMount footer, as indicated. Re-attach two screws "A", but keep it loose. Attach screw "B", and now fasten all screws.

The Pyrano mounting arm allows to adjust the pyranometer to variable tilt angles for GTI (Global Tilted Irradiance) measurement.

Only ONE (of three) possible ways of mounting the arm will ensure the correct North-South arm orientation, necessary for non 90° tilt angle adjustments, required for GTI measurement.

--	--

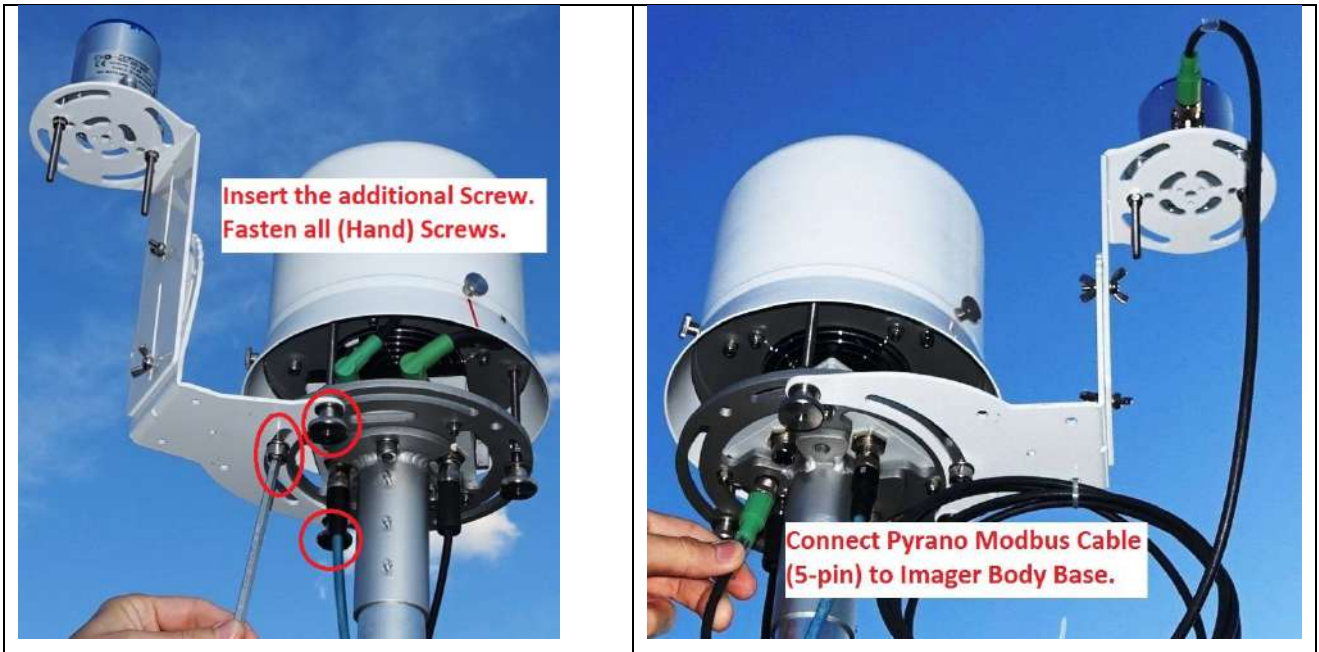

After mounting, use the "liquid Level" to adjust levelling of the Pyranometer!

9.3 xxx:

xxx

10 Mechanical & Electrical Drawings

10.1 ASI-16/5n Mechanical Drawings

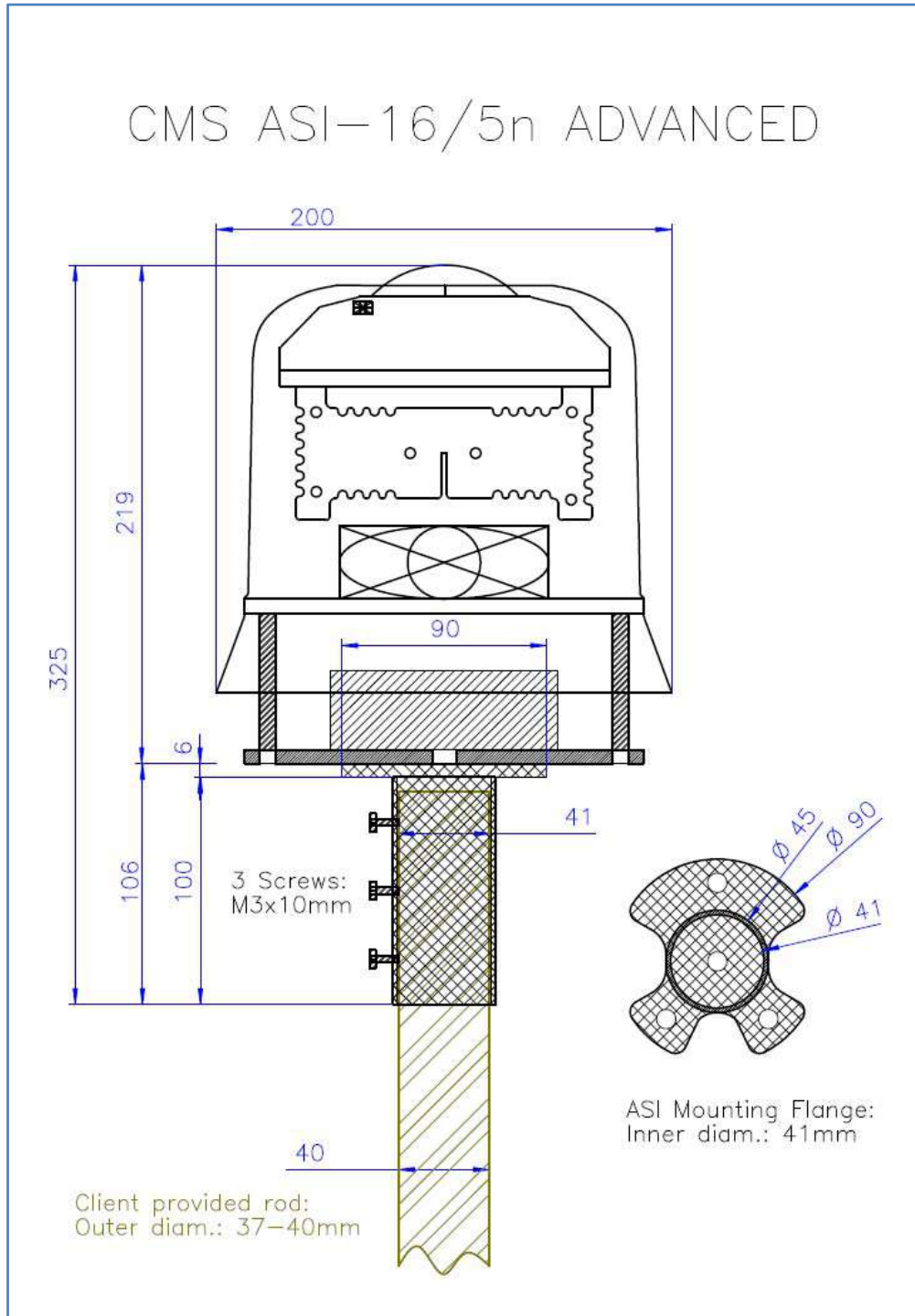

11 Service & Maintenance

11.1 ASI-16/5n - Hardware Reset after Severe Faults:

How to repair ASI-16 after severe software corruption?

An ASI can be found and accessed via it's IP, but ...

- (a) Web Browser shows corrupted screen without data/functions;
- (b) ASI16-Installer indicates "Failed to establish HTTP connection", and therefore cannot run ASI16-Installer "FULL RESET";
- (c) even after multiple power-off/on cycles and ASI16-Installer FULL RESET still some ASI functions do not perform as should.

In such cases some core OS/SW modules might have been corrupted. ASI must be reset to factory state, followed by ASI16-Installer re-install.

- (1) Download and install OEM Maintenance tools from below website:
<https://www.vivotek.com/shepherd#downloads>
- (2) Run "Shepherd2.exe", and find your ASI (IP, MAC-IC).

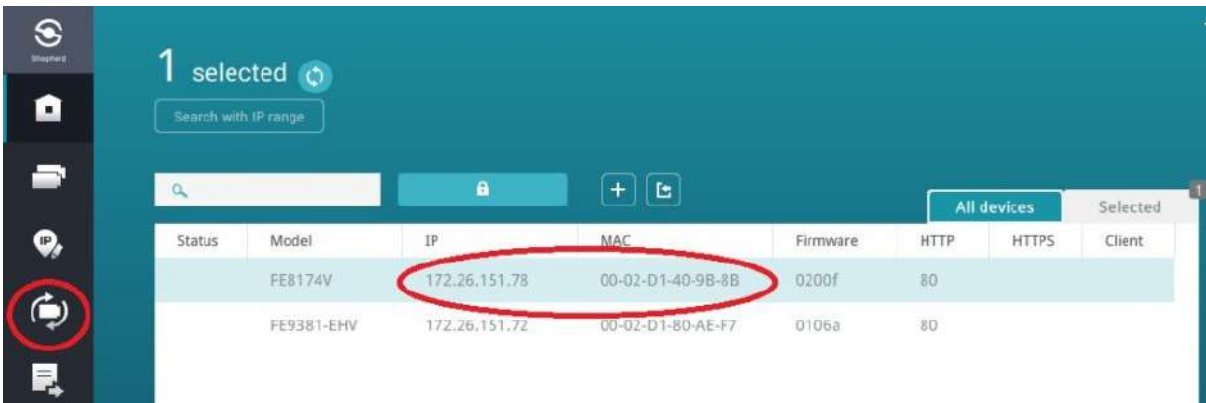

- (3) Mark the ASI, click on "Maintenance", and enter your LI/PW.

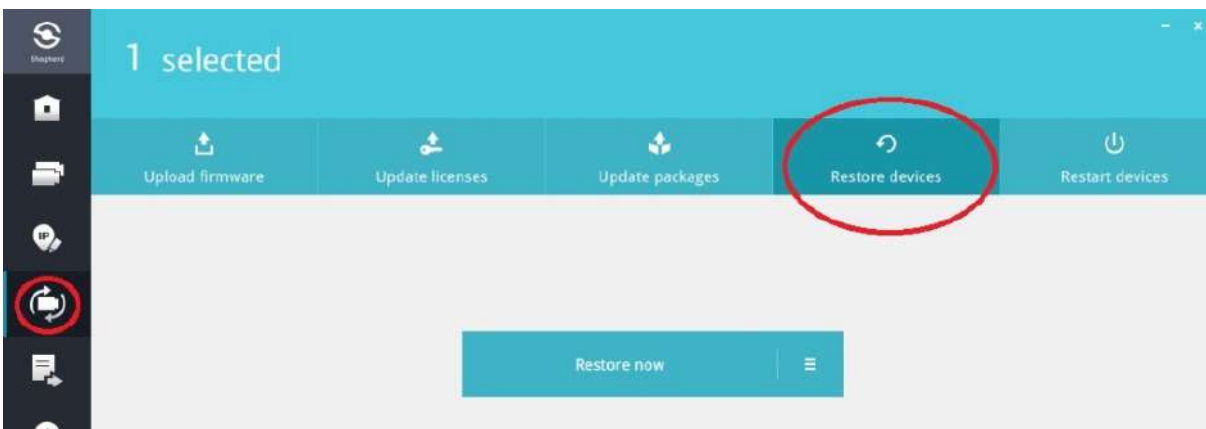

- (4) Select "Restore", start "Restore", and confirm all security questions without making any changes. Keep "Restore" process running for 15 minutes.

- (5) Close "Shepherd Tool", and power-off ASI for 30 seconds.
- (6) Power-on ASI again, and wait for 5 minutes.
- (7) Restart "Shepherd Tool", and re-run steps (2) to (6) once again.
- (8) Logon to CMS-CRM: <https://service.schreder-cms.com/crm/>
- (9) In CRM, check/update all CRM-stored imager data.
- (10) From CRM, download latest ASI16-Installer version.
- (11) Start ASI16-Installer, select Camera and "Update/Check".
Note: ASI SN will NOT be displayed, at that time! <https://service.schreder-cms.com/crm/>
- (12) Start "FULL RESET", and follow standard procedures.

11.2 ASI-16/5n Peripheral Controller - Firmware Upgrade

Firmware Upgrade via "Programming Adapter" and Laptop

This **PeriCon Firmware Upgrade Procedure** is required ==>> (A) in any case for all ASI-16/5n with Serial Numbers above SN 16101, and ==>> (B) in case of a previous PeriCon firmware update (via ASI Web-GUI) was interrupted by mistake, and after next Power-OFF/ON Peripheral Controller does NOT re-start and work anymore, as by (1) NO PeriCon LED blink signals, and (2) NO PeriCon SQNR-Data ("SQNR=12345; DATE=...") listed in ASI Web-GUI under ./Imager/Peripherals/General/[Logs].

(A) Preparations, Requirements:

- "ASI-16 PeriCon-USB Programming Adapter":
To connect the Peripheral Controller to a Laptop.
Cannot be directly plugged into a PC/LT US port.
Requires a standard USB cable as described below.
Supplied as LOAN ONLY by your EKO/CMS agent.
Must be returned to your agent within 2 weeks.



- USB cable, plugs type "Mini-A" to type "2.0 A".
- Laptop with fully loaded battery, running on Windows WIN-7 or later.
- Tools: 6mm hex wrench, if ASI must be taken down from its mounting rod. See 3.2
- For glass dome cleaning: Soft wet tissues, soft dry tissues.
- PeriCon programming software, firmware: ZIP-archive available for download in CMS-CRM.
WIN Software: "UpdateLoader-win32.exe/.ini". Firmware: "ASI-PeriCon_SRn_nnnnn.hex".

(B) Procedure:

1. CMS-CRM/Downloads: Download (a) latest "Release Notes_nnn.pdf", (b) latest "ASI16-Installer_V20.jar", and (c) latest "ASI-PeriCon_Firmware_yymmdd.zip".
Store "ASI16-Installer" to the PC connected to the ASI and Internet via LAN/router/switch.
Store "ASI-Pericon...zip" to the Laptop used outdoor (on site) to update Pericon firmware.
We recommend to unzip the entire "ASI-Pericon...zip" folder directly to the Desktop.
2. Office PC: Run ASI-Software "Full Reset" according to instructions in "Release Notes".
3. Prepare for safe physical access to the ASI-16 imager, outdoor on site or indoor.
 - 3.1 If the ASI can be accessed easily and without any risks of injury (falling down, slipping), then the ASI can remain on place, on the mounting rod. If wanted, remove the outer hood (green circle mark).
 - 3.2 Otherwise the ASI (without rod mounting flange) must be taken down, by taking out the three M8 screws (red square marks) at the mounting plate. The rod mounting flange shall stay on the rod, to avoid later mechanical re-adjustments, after re-mounting the camera.
4. Disconnect Data-Power cable (red mark) and cable to imager head (yellow mark).
5. Connect "PeriCont-USB Programming Adapter" via USB cable to Laptop.
6. Re-connect Data-Power cable, switch-on Laptop and start "UpdateLoader-win32.exe".

7. In "Port" select a serial port marked "FTDIBUS". If it does not appear, connect the adapter to another USB port on the Laptop, wait for driver installation, and try again.
8. In "Firmware-Update" select the "ASI-PeriCon_SRn_nnnnn.hex" file.
9. Double check all other settings, according to screen shots.
10. Click on "Update starten!". After a few seconds the update will start. DO NOT INTERRUPT!!!
12. Wait till "Update finished", and the PeriCon LED's show a white-yellow-green signal sequence.
13. Disconnect Data-Power cable (red mark) and "PeriCont-USB Programming Adapter".
14. Clean glass dome, first by a soft wet tissue, followed by a soft dry tissue.
15. Remove insects and/or other large particles from heating coil and fan protection.
16. Re-mount outer hood.
17. Re-connect cable to imager head (yellow mark) and Data-Power cable.
18. (Re-mount ASI to rod mounting flange.)
19. Office PC: Check entire functionality and settings via ASI-GUI (browser interface).

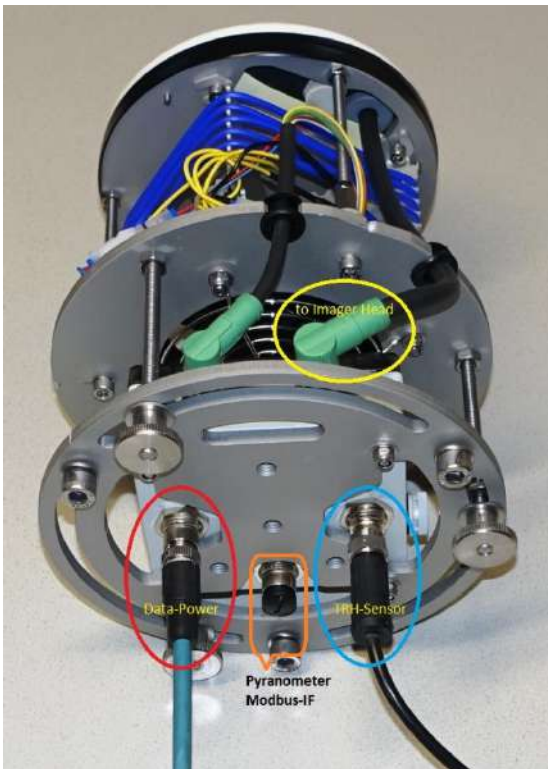

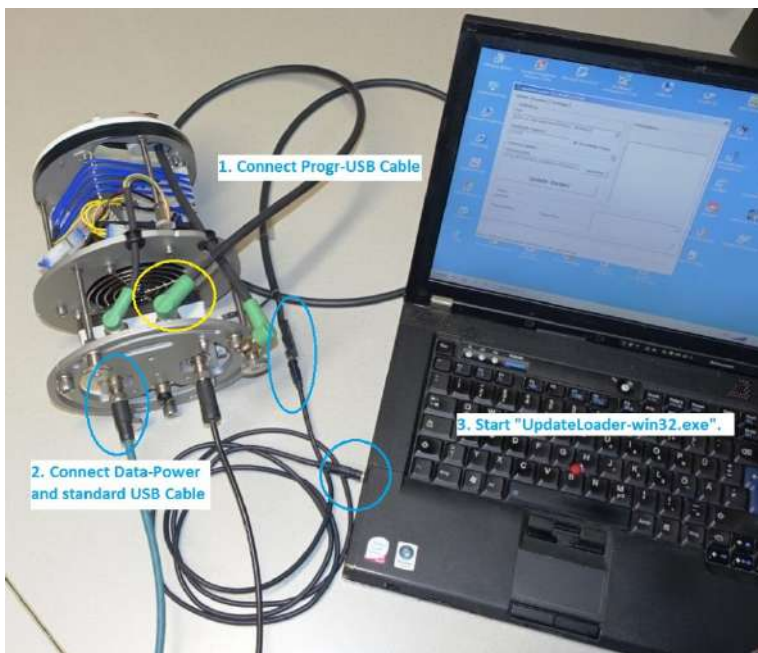
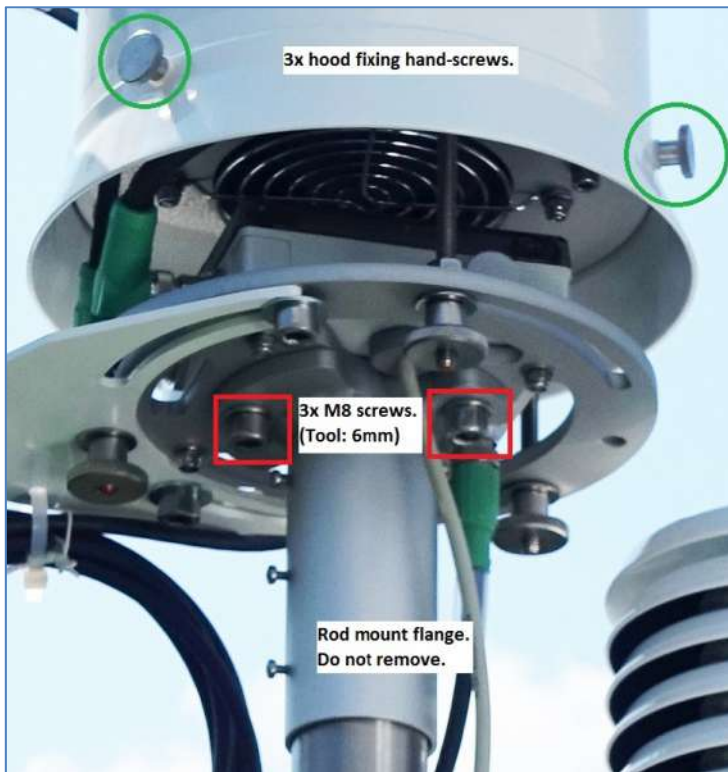

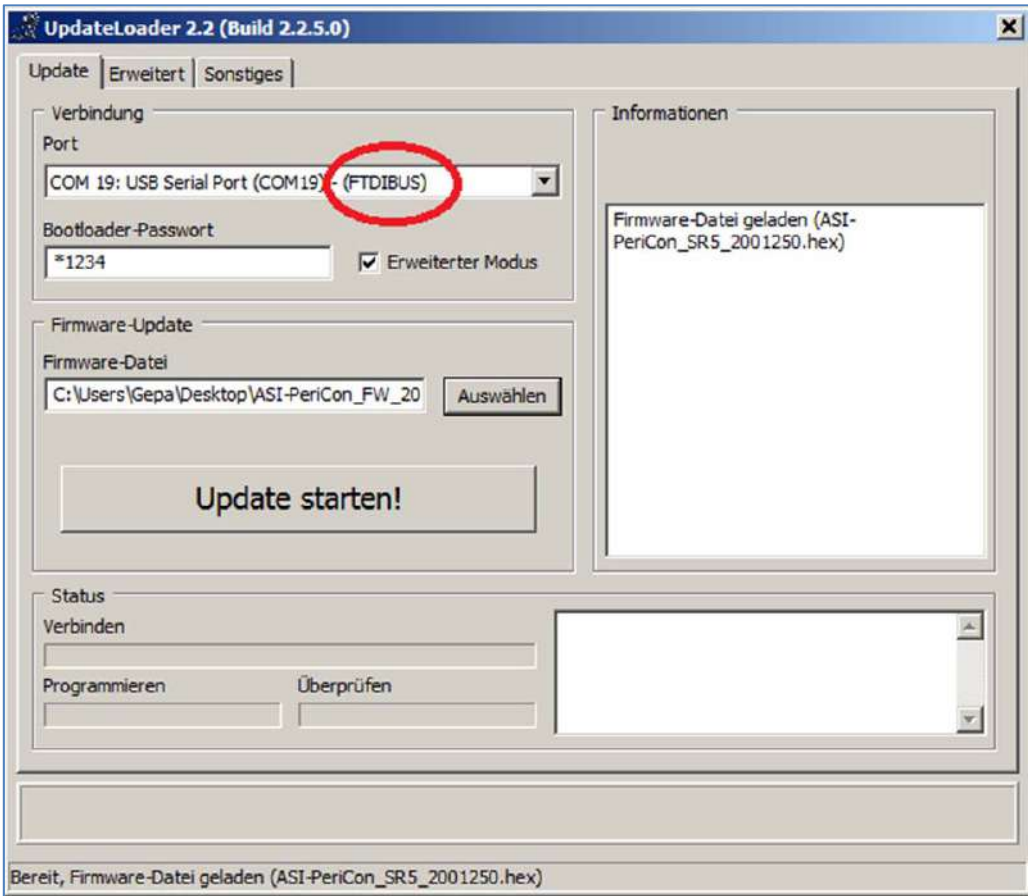
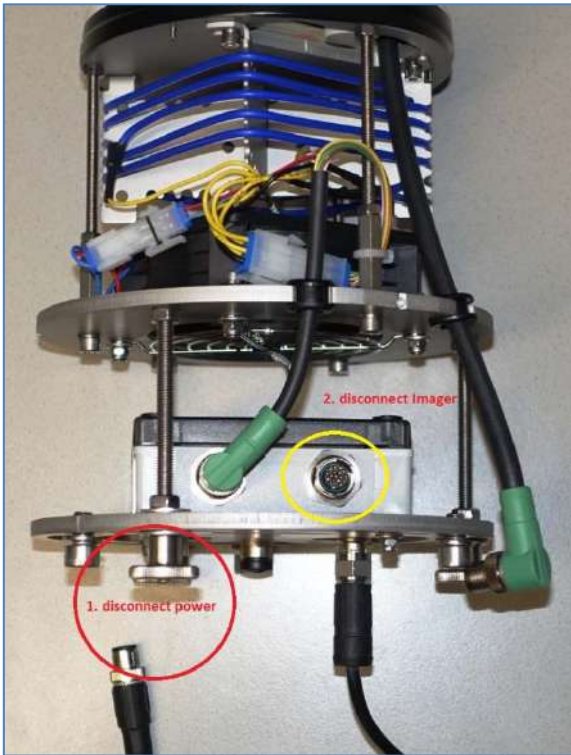

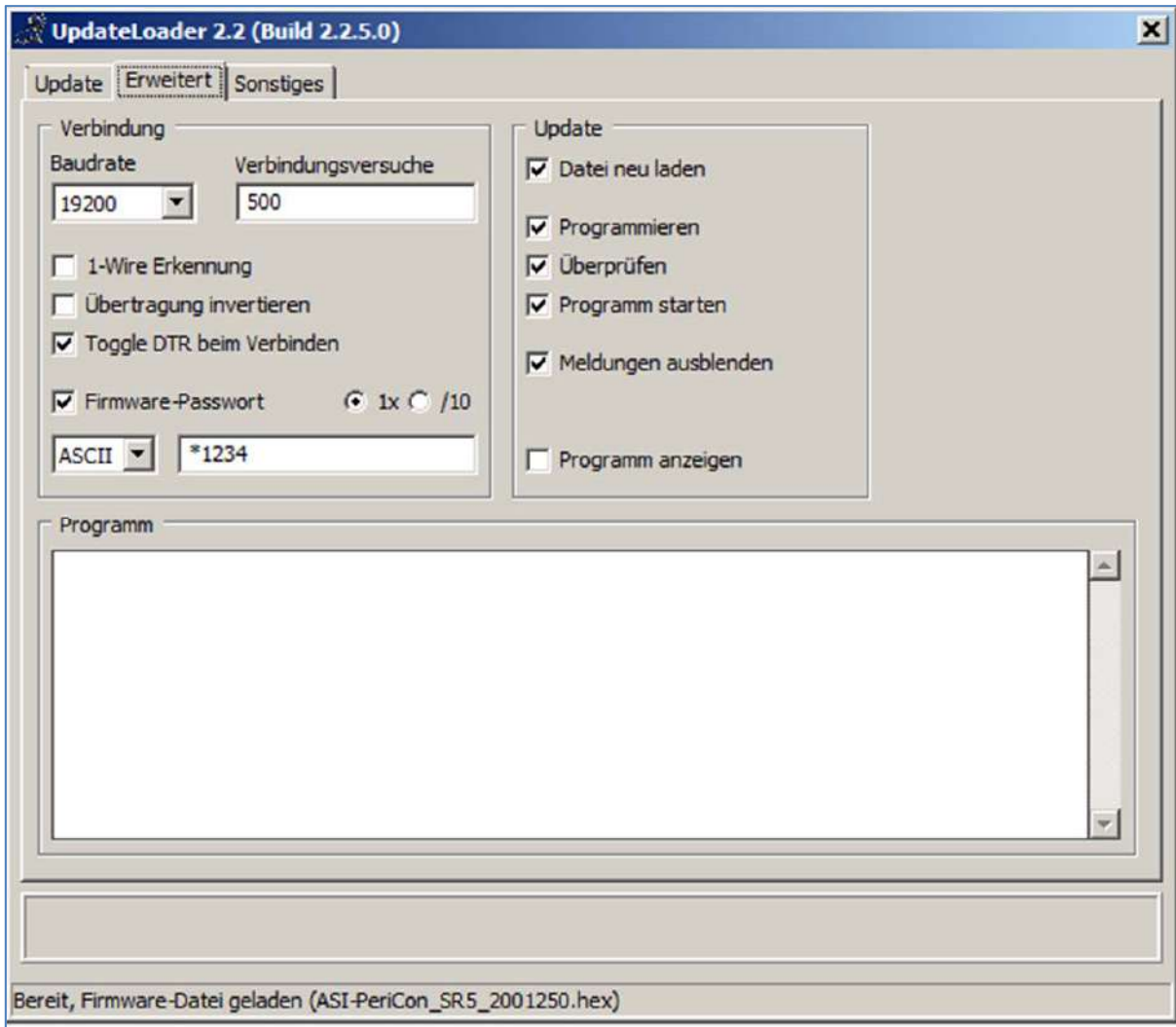

11.3 xxxx

xxx.

11.4 Spare Parts - Part Order Numbers - Refer to Price Table for details.

	<u>PART DESCRIPTION</u>	<u>ORDER NUMBER</u>
	ASI-16/55_V24 ADVANCED	1035.10.01.03
	Outer Hood (Outer Cover)	1035.110.90 
	Hood mounting screw	1035.130.34 
	Data/Power Cable, 20m	1035.210.15.2 
	CMS HPoE Injector	1035.160.00 
	AC Power Supply 48V, 90W	1035.210.11 
		Imager Head (complete)
Dome and Cover Assembly		1035.110.20.03 
Heater Star Assembly		1035.120.20 
Ventilation Unit Set (Fan)		1035.130.50 
Peripheral Controller		1035.150.00 
Multipole Cable (Heat/ Vent)		1035.150.70 
T/RH Sensor - standard		1035.150.40
T/RH Sensor - enh. protection		1035.150.47
Rod Mounting Shaft		1035.140.50 

12 Commercials - Legals - License - Conformity

12.1 Terms of Warranty

Seller hereby warrants the equipment to be free from defects in materials and workmanship, and the equipment being tested to perform according to material and critical specification, but warranty is limited to environmental and functional and operational restrictions, and limited to qualified installation, configuration and operation strictly according to Seller's instructions and to be performed under Buyer's responsibilities,

Within the limits of what is set forth above and below, Seller agrees to repair or replace, without cost of labour and parts to Buyer, any defective equipment or Buyer-serviceable modules or components, when such defect occurs within a period of twelve (12) months from the date in which Seller's goods have been put into use. The warranty duration is 12 months from installation date but never more than 18 months from invoice date, even if, for any reason, the equipment will not be utilized.

Buyer must immediately notify Seller of any defect, specifying the serial number of the equipment. At Seller's sole decision and notice, Buyer either shall send to Seller the defective item for repair or replacement, delivery at the Buyer's costs, and Seller will perform the repairs or provide a replacement within a reasonable period of time, or Seller will deliver replacement equipment or replacement spare parts and Buyer will perform the repair works. In any case, if not otherwise confirmed by Seller, Buyer shall be obliged to immediately, not later than 2 weeks after notice, return the defective equipment or defective components or modules to Seller, otherwise if Buyer fails to return Seller shall be entitled to charge and Buyer shall be obliged to pay the list price of the replacement parts delivered. Upon effecting such repair or replacement, Seller shall have fulfilled its warranty obligations.

Seller is not responsible for defects resulting from improper use of the equipment, lack of proper maintenance, tampering with the equipment, or by repairs effected by the Buyer which have not been approved by Seller in writing and in advance, or by the Buyer using spare parts not being delivered or approved by Seller, or the Buyer not strictly following Seller's instructions and advise for User repair and service procedures.

Seller will not be liable for any injury to persons or things, or for any direct or indirect commercial damages (loss of revenue or profit) due to the failure of operation or the loss of imager data, or instability or non-reliability of data generated by Seller's software.

Seller does not warrant the compliance of its equipment with the laws of non-EEC countries in which the equipment may be installed. Buyer shall indemnify and hold Seller harmless against any claim by third parties resulting from failure to comply with the aforesaid non-ECC laws and standards.

12.2 Contact

CMS Ing. Dr. Schreder GmbH.
Lofererstrasse 32, A-6322 Kirchbichl, Austria
Tel.: +43 (5332) 77056-00, Fax: +43 (5332) 77056-14,
Email: info@schreder-cms.com, Web: www.schreder-cms.com

12.3 Licenses, Liability, Confidentiality, Copyrights

12.3.1 MPEG-4 VISUAL TECHNOLOGY

THIS PRODUCT IS LICENSED UNDER THE MPEG-4 VISUAL PATENT PORTFOLIO LICENSE FOR THE PERSONAL AND NON-COMMERCIAL USE OF A CONSUMER FOR (i) ENCODING VIDEO IN COMPLIANCE WITH THE MPEG-4 VISUAL STANDARD ("MPEG-4 VIDEO") AND/OR (ii) DECODING MPEG-4 VIDEO THAT WAS ENCODED BY A CONSUMER ENGAGED IN A PERSONAL AND NON-COMMERCIAL ACTIVITY AND/OR WAS OBTAINED FROM A VIDEO PROVIDER LICENSED BY MPEG LA TO PROVIDE MPEG-4 VIDEO. NO LICENSE IS GRANTED OR SHALL BE IMPLIED FOR ANY OTHER USE. ADDITIONAL INFORMATION INCLUDING THAT RELATING TO PROMOTIONAL, INTERNAL AND COMMERCIAL USES AND LICENSING MAY BE OBTAINED FROM MPEG LA, LLC. PLEASE REFER TO [HTTP://WWW.MPEGLA.COM](http://www.mpeg-la.com).

12.3.2 LIABILITY

CMS-Schreder cannot be held responsible for any technical or typographical errors and reserves the right to make changes to the product and manuals without prior notice. CMS-Schreder makes no warranty of any kind with regard to the material contained within this document, including, but not limited to, the implied warranties of merchantability and fitness for any particular purpose.

12.3.3 CONFIDENTIALITY

The information disclosed with this document may contain technical and business secrets, and therefore has to be kept CONFIDENTIAL between CMS-Schreder and the receiving party. The information herein must not be released to any third party, for whatever reason, without the prior written approval of CMS-Schreder. - Necessary internal circulation and communication of this document and its material content must be limited to such persons and parties which have a reasonable demand of receiving this information for the business cooperation between CMS-Schreder and the receiving party. Circulation also has to be limited to such persons and/or parties who understand and will respect the confidentiality of the information provided herein.

12.3.4 COPYRIGHTS

The information disclosed with this document may include information and material being protected by copyrights of CMS-Schreder and by intellectual rights of third parties, and therefore must not be used in any other way as agreed and confirmed by CMS-Schreder.

12.4 EULA - End User License Agreement - (V03)

THIS IS A LIMITED LICENSE-TO-USE, NOT A SALE.

Unless otherwise mentioned in this "End User License Agreement" (EULA), and subject to payment of LICENSE FEE, this EULA gives you the right to install and use "CMS SOFTWARE" (SOFTWARE) on one single (1) SITE (address) within one (1) LAN (Local Area Network), within this site/LAN on one single (1) file server, but on multiple DT/LT computers connected to this server, the terms as set out below in more detail.

By receiving, installing or using the SOFTWARE and related DOCUMENTATION (collectively "SOFTWARE"), YOU agree to and enter into to this "End User License Agreement", which is entered into at the date of installing the SOFTWARE the very first time within your SITE/LAN computer or server, and is made between CMS ING. DR. SCHREDER GMBH., a Limited Company under the law of AUSTRIA, having its principal place of business at Lofererstrasse 32, A-6322 Kirchbichl, as LICENSOR, and YOU, your personal and/or company name and address as mentioned on invoices and/or other business documents which prove legal purchase and ownership of the LICENSE, as LICENSOR.

USER LICENSE: Subject to full payment of the LICENSE FEE as agreed and invoiced, CMS ING. DR. SCHREDER GMBH (CMS-Schreder, CMS, the LICENSOR) hereby grants to YOU (the LICENSEE) a non-exclusive, non-sub-licensable, limited-transferable, personal LICENSE to use the SOFTWARE. This Software is licensed "PER SITE" (per one single company postal address, per one single local area network), within this single SITE/LAN to be installed working with one single (1) file server, but on multiple DT/LT/PC computers, and is limited for the use with data from MAXIMUM up to FIVE (5) "named" ASI-16 imager. You hereby receive a usage right (license) only, but you do not own the Software itself.

LICENSE - LICENSE FEE - ASI-16 imagers: One (1) LICENSE will be granted by payment of one (1) LICENSE FEE. Such one (1) LICENSE allows use of the software with data for a MAXIMUM set of FIVE (5) "named" ASI-16 imagers, those imagers "named" by their individual specific ASI-16 serial numbers. Therefore, each (additional) set of respective five (5) ASI-16 imagers requires purchase of and payment for one (ADDITIONAL) LICENSE.

SOFTWARE OPTIONS - OPTION LICENSE FEES: Some optional software features (e.g. "CMV - Cloud Motion Vector Analysis", "CBH - Cloud Base Height Analysis) require the purchase and payment of additional OPTION LICENSES. - All terms, conditions and limitations hereunder apply for ALL CMS software products and all optional features.

LIMITED TRANSFERABLE: The limited right of the LICENSEE to transfer the LICENSE to one and one only LICENSEE's legal successor contractor, if any.

TRIAL LICENSE: Subject to special agreement with CMS-Schreder, you might have been granted and might have received a "Trial License", for time limited evaluation and testing purpose only. You NEVER must use such a "Trial License" and data generated from for any public or academic or commercial purpose, whatsoever. At the end of the Trial Period, without other agreement 30 (thirty) days after installation, you are OBLIGED to either (a) purchase and pay for a "User License", or (b) immediately stop use and DELETE the Software including all copies and generated data from all your computers and servers.

NO OTHER RIGHTS - RESTRICTED USE: CMS-Schreder reserves for itself all other rights and interest not explicitly granted under this EULA. YOU may not sell, rent, lease, resell, loan, and/or decompile, modify, alter, or create derivative works from the Software.

DELIVERY OF SOFTWARE, COPY PROTECTION: The Software is delivered via electronic means (Internet), by download access to the CMS-CRM-SERVER. Upon purchase and payment you receive a Login Name and a Password to access the CMS-CRM-SERVER, for download of latest versions of Software, Documents, and License Keys where applicable. The Software may include technical functions to restrict non-authorized copy and use, like license codes, and/or key codes, and/or binding to data from CMS provided hardware.

UPDATES: "UPDATE" means bug fixes and minor improvements within one "Major-Release-Version". Such updates will be made available from time to time, the time at CMS-Schreder's sole decision. Within the warranty period of 24 months, such updates will be free of charge, and will be made available via CMS-CRM download. After the warranty period further updates might be available against payment of a "Software Service Fee".

UPGRADES: "UPGRADE" means release of a new "Major-Release-Version", with new functions and features. Upgrades will be made available against an "Upgrade License Fee".

INTELLECTUAL PROPERTY: The Software is protected by Austrian and international copyright, patent and trademark laws and international treaty provisions. You acknowledge that you have only the limited, non-exclusive right to use and copy the Software as expressly stated in this EULA and that CMS-Schreder retains title to the Software and all other rights not expressly granted. You may not reverse engineer, decompile, decode, decrypt, disassemble, or derive any source code from the Software, and may not remove, alter, or obscure any copyright, trademark, or other proprietary rights notice on or in the Software.

USER FEEDBACK: Though no obligation, CMS-Schreder encourages you to provide CMS with ideas, suggestions, and/or proposals ("Feedback"). However, if you submit Feedback to CMS, you hereby grant CMS a nonexclusive, royalty-free, irrevocable, unlimited right to use your Feedback for any purpose, world-wide. Further, by submitting Feedback, you warrant that (a) your Feedback does not contain confidential or proprietary information of you or of third parties; (b) CMS is not under any obligation of confidentiality, express or implied, with respect to this Feedback; (c) CMS may have something similar to the Feedback already under consideration or development; and (d) you are not entitled to any compensation or reimbursement of any kind from CMS for the Feedback, under any circumstances.

USE OF DATA, DATA PROTECTION: For user convenience, some CMS-Services (online update, online backup, remote tech support, remote bug fixing) may require Internet Access and storage of some data at a CMS-CRM-Server. When using such CMS online-services, you hereby agree that CMS-Schreder is allowed to store "technical data" on its servers, and CMS and your local CMS-Agent/Distributor to have access to those data. CMS guarantees to use such data strictly internal and confidential, for technical support only. CMS and your local CMS-Agent/Distributor will never forward such data to any other third party, and will not use any such data for analysis, research, promotion, marketing, whatsoever. - To see and change your data, you can access to CMS-CRM, anytime, via your Login/Password.

LIMITED AND RESTRICTED WARRANTY: The Software, when properly installed and under normal use, will substantially conform to features and functionality as set forth in the Documentation. By known reasons, Software always contains remaining bugs, errors and limitations. Bugs, errors and limitations, if not substantial for the primary features, are NOT subject

to Warranty. Software is provided on the basis that remedies regarding such immaterial bugs and errors will only be provided from time to time by bug fixes.

TO THE EXTENT AS PERMITTED BY APPLICABLE LAW, THE SOFTWARE AND ANY SERVICES ARE PROVIDED "AS IS" WITHOUT WARRANTY OF ANY KIND, EITHER EXPRESS OR IMPLIED, INCLUDING, WITHOUT LIMITATION, THE IMPLIED WARRANTIES OF MERCHANTABILITY, FITNESS FOR A PARTICULAR PURPOSE, OR NONINFRINGEMENT. THE SOFTWARE IS PROVIDED WITH ALL FAULTS AND THE ENTIRE RISK AS TO SATISFACTORY QUALITY, USABILITY, PERFORMANCE, ACCURACY, SAFETY AND EFFORT IS WITH YOU.

THE SOFTWARE MAY CONTAIN "OPEN SOURCE" MATERIALS (E.G., ANY SOFTWARE SUBJECT TO OPEN SOURCE, GNU GENERAL PUBLIC LICENSE, PUBLIC DOMAIN LICENSES, OR SIMILAR LICENSE). CMS-SCHREDER MAKES NO WARRANTIES WITH RESPECT TO OPEN SOURCE MATERIALS CONTAINED.

LIMITATION OF LIABILITY: Except as otherwise provided by this contract, neither party shall be liable to the other for 1) any indirect, special, incidental, punitive or consequential damages; 2) loss of revenue; 3) loss of actual or anticipated profits; 4) loss of anticipated savings; 5) loss of business; 6) loss of opportunity; 7) loss of goodwill; 8) loss of reputation; 9) or loss or corruption of data. As between Battelle and Contractor, but not with respect to any third party liability or Contractor indemnification obligations, Contractor's total liability to Battelle for any direct damages arising out of or in connection with this contract (whether arising under tort, negligence, contract, warranty, or strict liability) will not exceed the contract price (or the aggregate amounts paid to Contractor under this contract).

TERMINATION: This EULA terminates if you fail to comply with its terms and conditions. If your EULA terminates, you must destroy all copies of the Software, and CMS-Schreder is entitled to block access to CMS services and delete data stored on CMS servers. The termination of this EULA does not limit CMS-Schreder's other rights it may have by law.

MISCELLANEOUS: This EULA is governed by the laws of AUSTRIA (EUROPE). If any provision of this EULA is held to be unenforceable, the remainder of the EULA shall not be affected, and the unenforceable provision shall be adapted to the extent as necessary to make the provision enforceable.

Version V03, 2024-05-02 (gepa)

(C) 2018 ... 2024 - CMS Ing. Dr. Schreder GmbH, Lofererstrasse 32, A-6322 Kirchbichl

12.5 EC - Declaration of Conformity

EG-Konformitätserklärung *Declaration of EC-conformity*

Für das folgend beschriebene Geräte
The following described item

ASI-16/55, ASI-16/15 All Sky Imager

wird hiermit bestätigt, dass es mit den Schutzanforderungen der folgenden Richtlinien übereinstimmt.

herewith is declared to be conform with the safety requirements stated in the EEC-regulation.

EMC Directive 2014/35/EU
RoHS Directive 2011 65 EU

Diese Erklärung gilt für alle Exemplare und verliert ihre Gültigkeit bei mit uns nicht abgestimmten Änderungen.

This specification applies to all specimens and is voided by not with us coordinated changes made.

Zur Beurteilung des Erzeugnisses hinsichtlich der elektromagnetischen Verträglichkeit wurde folgende Normen herangezogen:

For judging the products conformity the following standards have been applied:

EN 61000-6-1:2019
EN 61000-6-3:2011

Die Konformität dieses Produktes ist sichergestellt. Der Hersteller erklärt damit die alleinige Verantwortung für von ihm vertriebene Geräte des oben angegebenen Typs.

The conformity of this product is secured. The manufacturer declares hereby the sole responsibility for appliances mentioned above and produced by the manufacturer himself.

Hersteller/Importeur:
Producer / Importer

CMS - Ing. Dr. Schreder GmbH

Anschrift:
Address

Lofererstrasse 32 · 6322 Kirchbichl · Austria

Telefon:
Telephone

+43 (0)5332 77056-00

E-Mail / Web:
E-Mail / Web

info@schreder-cms.com / <http://www.schreder-cms.com>

Name des Unterzeichners:
Name of signer

Ing. Mag. Dr. Josef Schreder

Stellung im Unternehmen:
Position in Company

Managing Director

Kirchbichl

01.12.2023

Ort
place

Datum
date



rechtsverbindliche Unterschrift
legal signature