



PLANT - WATER - BIO-SENSORS - ENVIRONMENTAL - HYDROLOGY INSTRUMENTATION



Dynamax

Dynagage Sap Flow Sensor User Manual

**10808 Fallstone Rd #350 Houston TX 77099 USA
281-564-5100 www.dynamax.com admin@dynamax.com**

Copyright 2007, Dynamax Inc

All Rights Reserved

This manual refers to Dynagage sap flow sensors, specifications, theory and applications.

Specifications are subject to change. Dynagage is a new product for experimental purposes under development. DYNAMAX Inc assumes no liability for customer assistance, infringements of patents or copyrights arising from the use of this product. US Patents covering the construction of various stem flow gauges are No 5,337,604 and 5,269,183. DYNAMAX does not warrant or represent that any license, either express or implied, is granted under any patent right, copyright, or other intellectual property right of DYNAMAX relating to this product, or process. There are no implied warranties of merchantability or of fitness for a particular purpose given with the sale of any goods. DYNAMAX Inc shall not be liable for consequential, incidental or special charges.

IBM is a registered trademark of International Business Machines

VELCRO is a trademark of Velcro USA

Dynagage, Flow32, Flow32W and Dynamax are trademarks of Dynamax Inc

PC208W PC400 and LoggerNet are trademarks of Campbell Scientific Inc

Windows, Windows 95, Window 98, Windows NT, Windows2000, Windows Millennium, Microsoft Office, Microsoft Excel are trademarks of Microsoft Corporation.

Updated: 08/08/2022

TABLE OF CONTENTS

1.0	<i>INTRODUCTION TO DYNAGAGE</i>	5
1.1	Features	6
1.2	Benefits	6
1.3	Operation Overview and How to Use This Manual	7
1.4	Typical Stress Measurement Application	8
1.5	Examples of Species	9
1.6	Stem Flow Applications	10
2.0	<i>DYNAGAGE SPECIFICATIONS</i>	11
2.1	Mechanical Specifications	11
2.2	Electrical Specifications	12
2.2.1	Recommended Operating Conditions	12
2.2.2	Set Voltage to Dynagage	13
2.3	Dynagage Microsensors, SGA2, SGA3, & SGA5	15
2.3.1	Installation and Applications for the Microsensor	16
2.3.2	SGA2, SGA3 LOGGER SETUP	17
2.3.3	SGA2, SGA3 dX TC GAP SETUP	17
3.0	<i>STEM HEAT BALANCE THEORY</i>	18
3.1	Stem Heat Balance Basics	18
3.2	Energy Balance Equations	19
3.3	Sap Thermodynamics (equations in back)	21
3.4	Apparent KSH Calculation	22
3.5	Low Flow Rates	23
3.6	High Flow Rates	24
4.0	<i>DYNAGAGE INSTALLATION AND MAINTENANCE</i>	26
4.1	Unpacking	26
4.2	Preparing Stems	26
4.3	Preparing Trunks or Tree Branches	27
4.3.1	Sand Rough Stems	27
4.3.2	Check Fit on Trunk	27
4.3.3	Clean the Trunk and Apply Release Spray	27
4.3.4	Adventitious Root Prevention	28
4.4	Installing Gages	28
4.5	Install O-rings and Weather Shield	30

4.6	Shading Gauge And Trunk	32
4.6.1	Avoiding Errors in Sap Flow Data – Avoid Trunk Gages at Ground Level.....	34
4.6.2	Testing for and Avoiding Unwanted Trunk Temperature Gradients.....	34
4.6.3	Correcting Unavoidable dTg, Environmentally Induced Temp. Gradients	35
4.7	Expanding Gage Size	36
4.8	Reducing Gage Size	36
4.9	Guides to Removing Noise Sources - Avoiding Errors in Data.....	36
4.10	WARNING - Prevent Gage Damage - Gage Maintenance	38
4.11	CAUTION - Check Gages Weekly - Gage Maintenance	38
4.12	Expanding Girth	39
4.13	Bench Testing Gage and Fault Diagnosis – Maintenance	39
4.14	Annual Maintenance.....	40
4.15	Limited Warranty and Repair Policy	40

1.0 INTRODUCTION TO DYNAGAGE

Stem-Flow Gages produced by Dynamax Inc. are state of the art tools for the measurement of sap-flow in herbaceous plants and trees. An advanced energy balance method derived from a constant heat source monitors sap flow in plants from 2 mm (0.1") to 150mm (6") in diameter. Incorporated into the design is a patented electronic sensing method with three output channels per sensing device. The gages are precision instruments that sense mill watt power transfers from a heater strip to the ambient, to the stem, and into the sap flow. Sap cools off the heater in varying amounts corresponding to the flow rate.

Dynagage transducers use high durability insulation / dielectric materials and proprietary heater designs which ensure a durable and reliable product for field applications. Two readings from Dynagage signal temperature differences above and below the heater and concurrently measure the conducted stem heat transfer. A third reading from the Dynagage sensor measures radial heat flux, the heat lost to the ambient, from a thermopile, the set of junctions placed in series alternately adjacent to the heater, and on the outside surface of a thin cork annulus. The energy balance method also requires monitoring the voltage to the heater so that the constant energy input to the stem section is known with precision. Thus, a total of four data logger channels are required to monitor all of the signals pertaining to the sap flow computations. Each logger channel has a resolution and accuracy of ± 0.33 μV , however loggers with accuracy of 1.0 μV may provide satisfactory results.

Several scientific research institutions worldwide conducted many years of cooperative research and development on the constant-heat stem-flow technology. This culminated in successful product introductions with manufacturing methods and gage designs devised by Dynamax. The original heat pulse velocity (HPV) approach suggested by Huber in 1932 started many further efforts to employ the method and refine the theories. In contrast, stem heat balance (SHB) utilized by Dynamax was theorized in the 1970's and confirmed with experiments by Sakuratani and Baker-Van Bavel between 1981 and 1987. The stem heat balance approach requires no calibration or stem intrusion by temperature probes, two significant advantages over the HPV method. The sap flow measurements enabled by Dynagage have made a myriad of new studies and commercial field applications possible. The measurements are easy to make, accurate, and inexpensive when compared to all other available methods.



Figure 1.1 - Dynagages: Range of sizes

1.1 Features

The sap-flow can be computed and saved in grams per hour or per day by a formula using the heat applied to the stem, the radial energy from the stem, and temperature differences of sap above and below the strip heater. The stem flow gage has the following features:

- **Measures water use directly**
- **Portable. Reusable**
- **Non-invasive - Non intrusive**
- **Flexible collar straps around the plant stem**
- **Models to fit stem diameter from 2-150 mm. (0.1" - 6")**
- **Low time constant**
- **No calibration required - Absolute mass flow computation**
- **± 10% accuracy typical**
- **Self contained data loggers for real-time displays**
- **Low power requirement**
- **Outdoor weather shields**
- **Software Support on PC - Windows 95,98,NT**

1.2 Benefits

The users that need transpiration information will complement soil moisture depletion data with Dynagage. Plant growth models that simulate water use from meteorological data can be derived and made much more accurately with sap flow information. Leaf porometer readings and micrometeorological instruments are no substitute for a direct readout of the plant water flux using Dynagage. As long as the plants have stems in the size ranges available, the primary data is collected using a representative number of Dynagage, and then the transpiration of an entire crop is readily computed with reasonable accuracy. Other benefits of Dynagage - Flow4 Systems are:

- **Makes water consumption easy and inexpensive to record**
- **Usable from one season to the next, and on many species**
- **Harmless to the plant, and allows growth**
- **Installs in minutes. Daily expansion and contractions allowed**
- **Sensors for crops, shrubs, ornamentals, trees**
- **Works on dicots and monocots**
- **Can monitor plant reactions to rapid environmental changes**
- **Simple and quick to set up - easy Windows based interface**
- **Auto Zero software - adjusts Ksh based on expert software analysis**
- **Accurate predictions of water needs. Confidence in statistics**
- **Results available in real time, current information for decision**
- **Can run from solar panels and batteries**
- **Reliable outdoor operation - Handles water spray and rains**
- **Quick results and setup via Dynamax Flow32 system and graphics analysis**

1.3 Operation Overview and How to Use This Manual

Dynagage is a precision thermodynamic electronic sensor that measures water flow rates and the accumulated totals over time. The sensor specifications and power requirements are detailed in Section 2.0. The collar enclosing the electronics is placed around any smoothed and well-defined plant stem as long as the diameter fits within the ranges specified in the mechanical data (in Section 2.1) for each gage. The variety of applications and species may dictate adjustments and close monitoring of the instrument signals while verifying proper operation. Understanding the sensor and the plant thermodynamics found in Section 3 on Dynagage theory makes this task straightforward. As with any other precise measuring instrument, the correct installation technique is essential. See Section 3. Refer to Section 3.9 to 3.14 for the sensor maintenance as well as fault diagnosis and an overview on how to assure good results by avoiding errors. Weekly maintenance in the form of checking the gage contact with the stem, rapid crop plant growth, and checking for sap accumulation is required and described in Section 3.11.

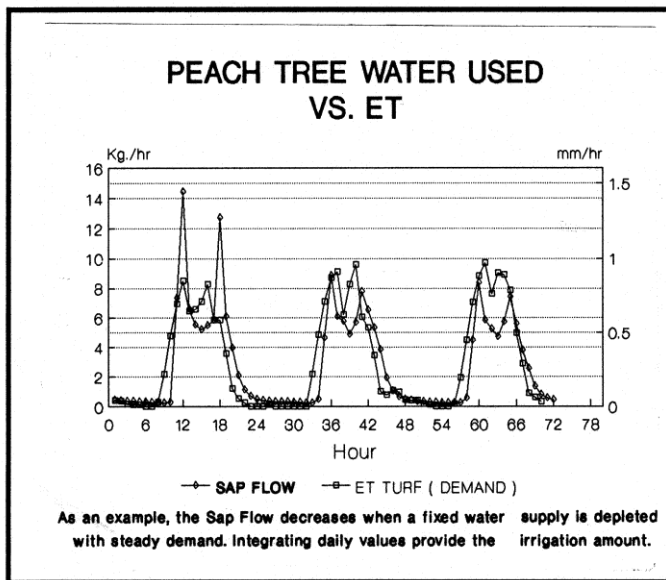

Figure 1.2 - Sap Flow vs. ET

Sizes larger than that from 35 to 150 mm are referred to as trunk-flow gages. The fundamental operation is the same, although there are different details of construction, such as the number of temperature sensors on the circumference and the number of thermopile junctions around the heater. The principles are the same and the majority of the installation details vary little.

The sensor has characteristics to record with the plant data to convert to a mass flow rate record to be accurate. Putting together any system with Dynagage has the same initial objective: to easily view and analyze the pattern of transpiration in comparison to the environment, and then to act upon that data. The example of sap flow per hour shown in Fig 1.2 could be compared to radiation over the three days. Then the sap flow accumulated for each day could determine the minimum amount of irrigation water that should be replenished.

After the data is gathered, the quality of the data and data analysis is critical. Automatic software or spreadsheet filters are employed to sieve out unusable or out of range data automatically. Depending on the logger system and the data retrieved for analysis, the flow rates and the accumulated totals may be compared to environmental or plant data gathered within the same logger or on other loggers.

The data logger and software installation manual explain the detailed installation of enclosures, cables, software and how to run the specific logger. Please refer to the data logger/system manual for instructions on connecting Dynagage sensor, monitoring and calculating sapflow.

For advanced users, and those who wish to supplement the real-time data analysis with off-line verification or recalculation of sap flow in EXCEL, for those trying to using applications other that excel data logger manual describes the actual formulas required for sap flow computations.

Terminology in This Manual

Within Dynamax terminology, sizes from SGA2 to SGA5 are called Microsensors. Gages from 9 up to 24 mm are defined as stem-flow gages.

1.4 Typical Stress Measurement Application

By continuously reporting the hourly water use rate of a tree, vine, or crop, a sap flow gage can record any change in the daily pattern of transpiration that reveals a shortage of water and the need for replenishment of the soil moisture supply. As an example, Figure 1.2 shows the sap flow of two trees, a peach and a pecan planted in lysimeters, compared with the demand calculated from the Penman-Van Bavel ETP program. The trees were well watered before the test, but sap flow was unable to keep up with demand. The peach tree sap flow declined 26% by the third day when faced with steady demand, experiencing a water deficit. The water stress index may be easily calculated for plants having the same demand defined by the ETP, or by direct comparison of a well-watered plant (T_{ww}) and a stressed plant (T_{str}). The stress index for peach tree on the third day compared to the first day is therefore:

$$C.W.S.I. = 1 - T_{str} / T_{ww} = 1 - 60 / 81.3 = 0.26$$

Using this convention, the tree with a stress index of zero has no transpiration drop, and the tree having a stress index of one, is not transpiring. The crop stress index can be applied to any type of stress for heat, disease, pollution, or any other environmental factor. When working with orchards or field crops, this information is invaluable as it is not directly obtainable in any other way.

Dynagage Applications

Agricultural Engineer	Hydrology
Agriculture Consultant	Irrigation Systems
Botany	Orchard Monitor
Citrus Grower	Ornamentals Farm
Crop Science	Plant Physiologist
Crop Physiology	Pollution Studies
Extension Service	Phytoremediation
Fertilizer Evaluation	Reforestation
Genetic Engineering	River Authority
Greenhouse Control	Seed Genetics
Farm Industry	Tree Farm
Forestry Company	Weed Science
Horticulture	Xeriscaping



Figure 1.3 - Dynagage

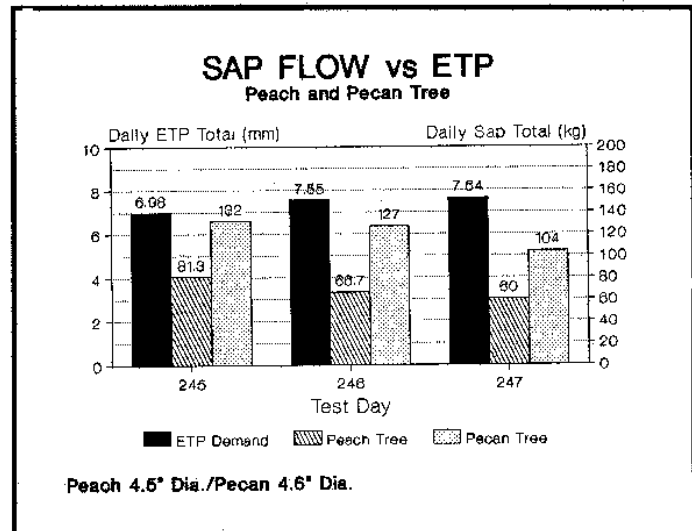

Figure 1.4 - Sap Flow Vs. ETP

1.5 Examples of Species

Fig. 1.5 contains a partial list of the species that have been monitored successfully with Dynagage technology. In general, these species were confirmed by operation of Dynagage on a lysimeter plant (soil covered). In some cases the agreement between the lysimeter is within 5% of the Dynagage total for a 24-hour test period. In larger species containing a large mass of water above the gage, transpiration agrees with accumulated sap flow on a 24-hour basis.

CROPS	TREES	OTHER
CUCUMBER	ALMOND	LIGUSTRUM
COTTON	ASH	MESQUITE
CORN	BALD CYPRESS	RUBBERPLANT
SORGHUM	RED CEDAR	ROSE
SUNFLOWER	OAK	GRAPE
SUGARCANE	DOUGLAS FIR	FRUIT PEDUNCLES
SWEET POTATO	FICUS	STOMATAL
TOMATO	PEACH	OSCILLATIONS
POTATO	PECAN	MANGOSTEEN
SOYBEAN	PINE	COFFEE
	POPLAR	
	TANGERINE	
	LOBLOLLY PINE	
	WILLOW	
	ACACIA KOA	

Figure 1.5 - Species Successfully Monitored with Dynagage

1.6 Stem Flow Applications

As water requirement-forecasting tool, the species under observation with Dynagage is monitored in comparison to the weather and tracked during the growing season. When the radiation or weather pattern is forecast for the same crop in another location with similar soil characteristics, the water budget for irrigation is assessed. The crop index is directly computed by translating the water use of the plant population to a land area basis, and then computing the transpiration divided by the ETP index. Since the quilt work of soil characteristics, topology, and prevailing weather adds uncertainty to this forecast, the user is recommended to make periodic sap flow tests within the field under question. In an irrigation or greenhouse fertigation application, the sap flow of a predefined volume can be used to regulate micro irrigation controllers as opposed to using models. In this case the "speaking plant" defines its own water requirements.

Forest canopy and ecological studies are now possible with sap flow measurement on the tree trunk or in the branches of the canopy. By monitoring the transpiration and the weather along with the leaf conductance, one can determine the decoupling of the leaf stomatal response from the atmosphere. Having the actual transpiration of a tree divided among the layers of the canopy determines the hydraulic conductances in the canopy as it varies by radiation level and microclimate.

Observing the sap flow may also monitor the health of a plant. Root damages, insect damage and competition with weeds can be quantified and compared to healthy plants, or by observation of the crop over time. Air quality is an increasing area of concern. The effect of pollutants on the process of photosynthesis and respiration are indirectly measured via sap flow instrumentation, as long as plants can be isolated from the pollution to provide a benchmark against plants in polluted air. The effects of treatments to counter cell destruction by pollution in either the ground water or the air may be established clearly with monitoring by Dynagage.

Agricultural engineers in arid lands can efficiently design drip and sprinkler irrigation systems with sap flow information. The closed loop feedback system, which determines the application of water from the actual plant use will have the greatest accuracy and therefore yield improvements. Seasonal and weather related variations in water demand are precisely determined for real-time systems. Water consumption data then determines the quantity of water delivered on the next irrigation cycle.

The effects of antitranspirants on water savings can be determined by comparing water use on a representative number of treated plants against a similar number of untreated plants. The alternative of using lysimeters, either weighing or volumetric, has a negative impact on the root zone, and may not be as representative of the real crop physiology as the direct measurement by Dynagage in the field. The transpiration tests can be performed more realistically with Dynagage.

Water management, hydrology, and water quality studies now have the tools to separate water flux into transpiration from the plants vs. soil evaporation and leaching. The sap flow information on stream bank vegetation, phreatophytes, and rangeland invaders such as mesquite, and cedar trees, provides the user with the water flux data that is essentially unavailable from other sources. Dynagage may also solve potential applications having great benefit to the plant breeding and farming industry. Breeders can observe genetic engineered plants for resistance to drought, growth patterns, water, and fertilizer efficiency.

Dynagage may also solve potential applications having great benefit to the plant breeding and farming industry. Breeder can observe genetic engineered plants for resistance to drought, growth patterns, water, and fertilizer efficiency.

2.0 DYNAGAGE SPECIFICATIONS

Dynagages have a soft foam collar that surrounds the electronics. The unit is installed on a stem having an axial length of at least the gage height, which is cleared of branches and smoothed. A weather shield is installed for outdoor applications and radiation shielding. The specification for the gage diameter is the determining factor for selection of a gage, which fits properly. Find the diameter of the plants to be tested with a girth tape, or other measurement of the circumference. Convert this to diameter and check the table of stem diameter ranges. Choosing a gage that is the typical size or close to the minimum size will provide ample room for plant growth. The sensor can also be moved higher on the stem to fit a smaller diameter or lower to fit a larger diameter. An insulation wedge can be obtained to fill the gap when expanding the gage to the maximum diameter limit. Above the maximum diameter, the heater strip will not completely encircle the stem or trunk, causing insufficient and uneven heating.

2.1 Mechanical Specifications

Model No.	Gage Height (mm)	Shield Height (mm)	Stem Diameter (mm)			TC Gap dX (mm)	No. Pairs	Input Voltage (Volts)	Input Power (Watts)
			Min.	Typ.	Max.*				
Micro Flow Gages									
SGA2-ws	35	70	2.1	2.5	3.5	1.0	1	2.3	.05
SGA3-ws	35	70	2.75	3.0	4.0	1.0	1	2.3	.05
SGA5-ws	35	70	5	5.5	7	3.0	2	4.0	0.08
Stem Flow Gage									
SGB9-ws	70	180	8	9	10	4.0	2	4.0	0.10
SGA10-ws	70	180	9.5	10	13	4.0	2	4.0	0.10
SGA13-ws	70	180	12	13	16	4.0	2	4.0	0.15
SGB16-ws	70	200	15	16	19	5.0	2	4.5	0.20
SGB19-ws	130	250	18	19	23	5.0	2	4.5	0.30
SGB25-ws	110	280	24	28	32	7.0	2	4.5	0.50
Trunk Gages									
SGB35-ws	255	460	32	41	45	10.0	4	6.0	0.90
SGB50-ws	305	505	45	50	65	10.0	8	6.0	1.4
SGA70-ws	410	610	65	70	90	13.0	8	6.0	1.6
SGA100-ws	460	660	100	110	125	15.0	8	8.5	4.0
SGA150-ws	900	1,129	125	150	165	20.0	8	9.0	4.0

Figure 2.1 - Dynagage Mechanical Specifications

* Maximum diameter includes inserting a 2 to 4 cm foam wedge into insulator gap and enclosing with Velcro Straps. 0 / *1 - SGA2, SGA3 Micro sensors have one pair of TC, thus no separation. **Enter the value of one (1.0) in the dX value to compute a dummy Qv. (See Microsensor specs in SEC. 2.3)**

2.2 Electrical Specifications

2.2.1 Recommended Operating Conditions

The recommended operating conditions vary by the stem diameter and the heat requirement of the water to obtain easily measurable results. For initial gage start-up, low-level radiation in various laboratory conditions, or winter (low level) flow rates, the minimum input to the heater must be used. To achieve the best results over medium flow rates (see Table 1), the Typ - Typical voltage is recommended to supply heater power.

Heater input voltage D.C. Measured at device terminals D (+), E (-)				
Part Number	Min	Typ	Max	Unit
SGA2	2.1	2.3	2.5	V.
SGA3	2.2	2.5	2.7	V.
SGA5	3.5	4.0	4.5	V.
SGB9	3.5	4.0	5.0	V.
SGA10	3.5	4.0	5.0	V.
SGA13	3.5	4.0	5.0	V.
SGB16	3.5	4.5	5.0	V.
SGB19	3.5	4.5	5.0	V.
SGB25	3.5	4.0	5.0	V.
SGB35	4.5	5.5	7.0	V.
SGB50	4.5	5.5	7.0	V.
SGA70	5.0	6.0	7.0	V.
SGA100	6.0	8.5	10.0	V.
SGA150	8.5	9.0	10.0	V.

Table 2.1 - Recommended Heater Input Voltage

Heater Input power Recommended for each; Pin = V*V/R				
Part Number	Min	Typ	Max	Unit
SGA2	.04	.05	.06	W.
SGA3	.05	.06	.07	W.
SGA5	.05	.08	.10	W.
SGB9	.06	.12	.15	W.
SGA10	.06	.12	.15	W.
SGA13	.09	.17	.20	W.
SGB16	.10	.20	.25	W.
SGB19	.16	.30	.40	W.
SGB25	.26	.4	.5	W.
SGB35	.45	.75	1.2	W.
SGB50	.70	1.2	2.0	W.
SGA70	1.1	1.6	2.5	W.
SGA100	2.0	4.0	5.5	W.
SGA150	9.6	10.8	13.3	W.

Table 2.2 - Recommended Heater Input Power

Input power listed in Table 2 is broken down into three ranges. The customer is responsible for the power setting selection for the application, which varies by species and environment. The gage serial number tag contains resistance figures used to compute the Direct Current supply power settings ($P=V^2/R$).

Minimum Power is recommended for starting up all sensors, and to operate on low transpiration plants.

2.2.2 Set Voltage to Dynagage

CAUTION - ADJUST SENSOR VOLTAGES CORRECTLY

Minimum power is recommended for starting up all sensors, and to operate on low transpiration plants such as tropical species and most conifers. We also recommended minimum power for the low flow levels on any plant during **winter, fall, indoor or greenhouse** experiments under the normally low lighting levels, less than 400 W/sq. m. **Always start your settings at the minimum voltage / minimum power setting. After monitoring a few normal days and there is insufficient dT signal, only then increase to the higher (Typical) levels necessary.**

Typical power is appropriate if the plant is a medium transpiration plant. Also use **Typical** when solar radiation levels are consistently low, between 400-1000 W/sq m. In this case plants will not be using as much water as they normally might. Typical settings are also for robust crops, using the nightly power down mode available with most loggers. Power down mode is recommended for long-term usage, especially when the species has a delicate cambium. This **setting is OK as long as dT is less than 6C** at its morning peak.

The Maximum power is applied when solar radiation is over 1000 W/sq m, on species having very high flow rates, and when plenty of water is available to the plant. **Max Power may be necessary to get a good dT signal. This setting should be for tests of short duration,** one week at a time, when the operator can monitor the dT often. If the dT is over 7° C consistently, reduce the power 12%, and therefore reduce dT 12% (Reduce voltage 10%). For long-term readings the nightly power down mode is necessary to prevent cambium damage. A complete discussion of the reasons for regulating temperature and power supplies at various settings is found in data logger manual.

Model	Min	Typ	Max	Units
SGA2	80	90	100	Ohm
SGA3	100	110	120	Ohm
SGA5	170	190	200	Ohm
SGB9	105	120	135	Ohm
SGA10	120	150	170	Ohm
SGA13	105	120	135	Ohm
SGB16	50	100	120	Ohm
SGB19	50	65	75	Ohm
SGB25	38	43	47	Ohm
SGB35	35	40	45	Ohm
SGB50	21	25	29	Ohm
SGA70	20	22	25	Ohm
SGA100	16	18	20	Ohm
SGA150	7	7.6	8	Ohm

Table 2.3 - Heater element impedances. A 10% variation from unit to unit is normal. An upgrade in design may change impedances without notice to improve compatibility.

<i>Absolute maximum power & environmental limits</i>	MAX	MODEL
<i>Absolute maximum power applied to heater (D-E)</i>	0.2 Watt	SGA2, SGA3, SGA5
<i>If you exceed this specification it voids the Warranty.</i>	0.5 Watt	SGA 9, 10, 13, 16
<i>This specification is the maximum power which</i>	2.0 Watt	SGB19, SGB25
<i>can be applied without damage to the gage heater,</i>	5.0 Watt	SGB35, SGB50
<i>NOT the maximum you should apply to the plant.</i>	10. Watt	SGA70, SGA100
<i>Maximum operating temperature</i>	45° C.	All
<i>Maximum storage temperature</i>	60° C.	Models

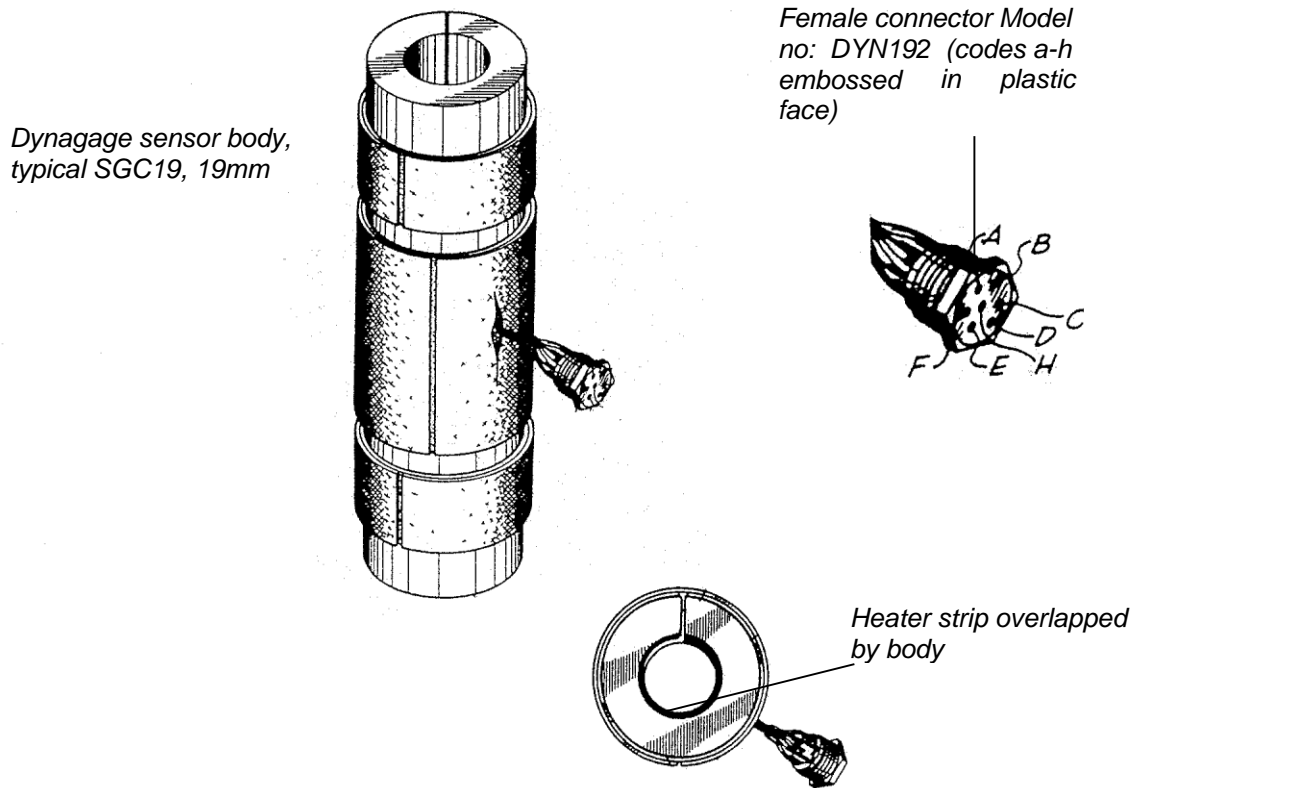
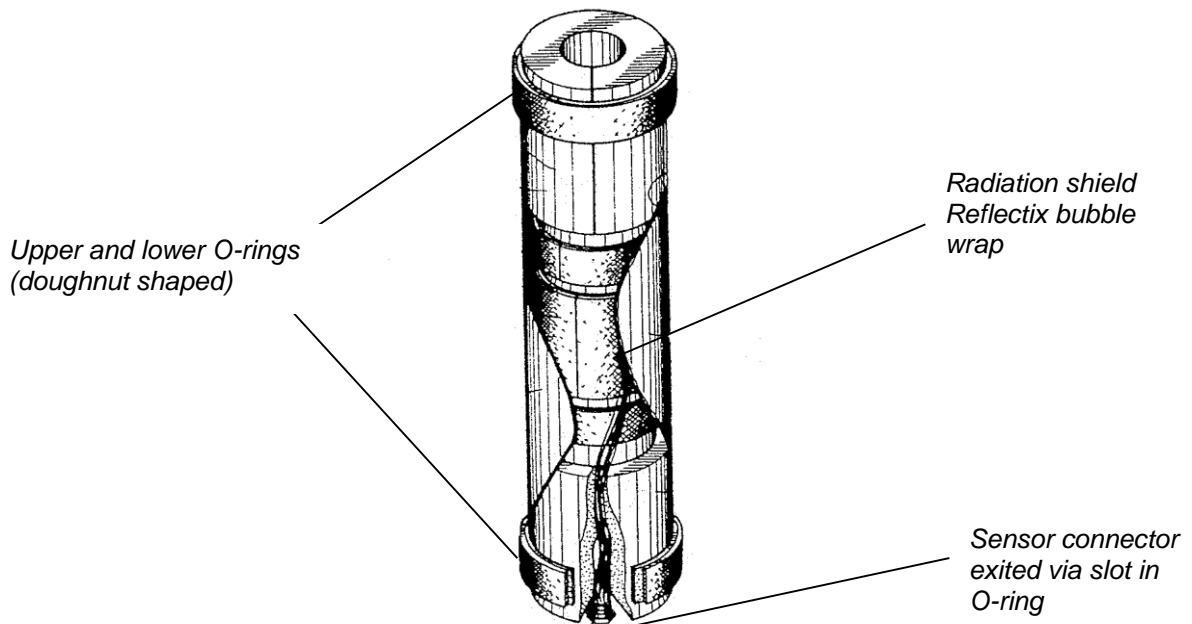

Figure 2.2 Sensor Mechanical Diagram – With weather shield assembly



2.3 Dynagage Microsensors, SGA2, SGA3, & SGA5

Specification Addendum

The Dynagage Microsensors are for sap-flow measurement sensor applications on small diameter crop plants such as wheat having an oval 3X6 mm stem. Water usage or transpiration of small deciduous, conifers, ornamentals and nursery stock plants with round stem diameters of 2 - 4 mm can be determined. This section describes the unusual specifications, and special considerations when applying the SGA2, SGA3 and SGA5 models.

Features:

The Microsensor design has an innovative new concept in the construction of portable energy balance, constant heating sap-flow gages. The Microsensors features a rigid acrylic clamshell design with the heating element and the heat flux electronics mounted in one half of the cylinder, and the other half-cylinder is closed firmly, holding the sensor around the stem. Insulating rings are provided to protect the gage from radiation, water, and extreme ambient changes. Internally, a flexible foam material supports temperature sensors in such a way that the sensor conforms to the stem shape and irregularities including oval shapes.



Figure 2.3 - Micro sensor

The internal wiring of the SGA2, SGA3 and SGA5 includes only one TC pair, and only one dT signal due to size and accuracy (contact) considerations. Thus the sensor's connector has a jumper to connect the Ah and Bh signals together. The signal is read twice by the logger, and averaged in a compatible means with all other sensors. Also Qv is essentially zero, and the minimal heat one would conduct is practically ignored (Stem area is so small). The Qr heat equation, by virtue of the zero set procedure, will proportionally compensate for any missing energy in the heat balance.

Features:

- Durable rigid shell
- Very low power requirement typically 0.05 W
- Time constant under 10 minutes for dynamic readout
- Absolute mass flow method
- Oval or round stems
- Patented clamshell installation with Stretch Velcro
- Software & hardware compatible with all other Dynagages

Mechanical Specification					
Model Number	Stem Diameter Range			Height	Unit
	Min	Typ	Max	Min	See Note 1
SGA2 RoundStems	2.1	2.5	3.5	70	mm.
SGA3 RoundStems 2.75 OvalStems (axb)	3.0 2x3	4.0	70 3.5x6	70	mm. mm.
Thermocouple Gap - NONE For Software Only	1.0	1.0	1.0		See Note 2 mm
Electrical - Thermal Specifications					
Maximum operating temperature					40 C.
Maximum storage temperature					60 C.
	Min	Typ	Max	Unit	
Heater Excitation	2.1	2.3	2.5	Volts D.C.	See Note 3.
Heater Impedance	80	100	120	Ohms	
Heater Power	0.04	0.05	0.07	Watts	
Operating temp.	5	25	35	C.	
Notes: 1. Maximum diameter range includes placing an insulating strip in the gap between acrylic shells. This wedge is a small strip of adhesive silicone foam rubber gasket. Cut strips to fit gap as needed. Minimum gauge height including complete weather shield installation kit. Gauge height without shield is 30 mm. 2. SGA2, -3 have one TC differential reading only (one pair), and therefore it assumes Qv=0, however to maintain similar software support for all sensors, one must enter something as the dX gap. Use 1.0 mm as the default, and the usual sap flow calculation will work. 3. Always start at minimum power for tropical, indoor, or other low sap flow applications.					

Protected by USA Patents

2.3.1 Installation and Applications for the Microsensor

The SGA2 -3 and -5 are shipped complete with radiation shielding and foam O-rings to keep moisture and ambient swings from altering the energy balance dramatically. The items included with the gage are as follows:

- 1) SGA2, 3, 5 Gage shell.
- 2) Insulation body - shield.
- 3) Upper O-ring
- 4) Lower O-ring
- (Items not shown below)
- 5) G4 electrical compound (5 oz per order)
- 6) TFE – Canola Oil/ releasing spray
- 7) Strip of White -Tack sealer.
- 8) Dynagage Installation and Operation Manual
- 9) Two Orange foam rubber insulating strips, with self-adhesive backs

Attach the cable to the gage 7-pin terminal (7), and record the sensor heater impedance recorded on the sensor serial tag, while making note of the connector number, and plant diameter for computing constants that load into the sap flow analysis program. Support the cable carefully on the stem with a nylon tie or a stake if necessary to support its weight. Section 4 in this manual contains the details of stem preparation, which includes cleaning roughness from the stem, if any. Then TFE Canola oil release spray (item 5) is applied to the stem section sparingly. Apply G4 to the heater with a q-tip so it will slide into position. The heater is the yellow-brown strip in the center of item (1). Then place the gage body (1) on the stem carefully avoiding abrasion on the exposed thermocouples, observing direction of the flow arrow. Next, begin closing the shell, and using a small screwdriver, or a pencil tip, press the heater strip against the stem inside the electronics shell half so that it neatly overlaps the heater strip. For oval stems, flatten opposite sides of the heater over the oval shape. Then the shell halves can be closed. Using the stretch Velcro straps, secure the two halves of the cylinder, and tighten/ press into the hook Velcro on the gage body to close the device securely.

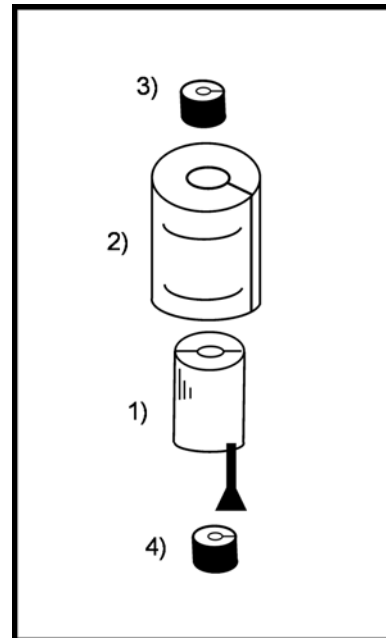

Figure 2.4 - Micro sensor Installation

If a gage is installed on a stem on the high end of the diameter range, there may be an opening visible between the shells. **Then you must insert a small strip of foam insulation (8) in the gage shell gap adjacent to the stem before closing the shell.** The foam strips of insulating rubber can be cut to size to fit the gap. This is a precaution against uneven heat transfer affecting the readings. In indoor or outdoor situations O-rings (items 3 & 4) should be sparingly sealed with G4, and slipped onto the stem directly above and one directly below the gage body. Next, the outer insulation sleeve (2) is installed over the assembly. The cable connector (7) fits down the slot of the insulator body (2), and then the Velcro straps (8) are used to close the insulation body. A thin bead of white - Tack can then seal water out by applying to an exposed gap. A stake or rod is used to support the assembly on grain applications or weak seedling stems needing support.

The sensor installation steps pertaining to the Microsensor are now complete, and the usual remaining steps, aluminum foil cover, etc. are described in this manual, in Section 4. Software procedures for setting the zero, Ksh, and then computing sap flow are processed next, as explained in the datalogger manuals.

2.3.2 SGA2, SGA3 LOGGER SETUP

To get the most out of the SGA2 and SGA3 accuracy with readings **in real-time**, CR10, CR10X, or 21X data loggers, it is necessary to program output data and intermediate calculation with double precision, so all readings including sap flow have five decimal places after the decimal point. Since Watts are the units used in calculating sap flow, the double precision is needed for enough resolution in the results. Since there is a very small amount of power in the entire energy balance, around 0.050 Watts, each of the energy balance partitions needs to be calculated with a precision in the microwatt range.

Since this conversion to double precision is not compatible for the standard Flow32 setup and DLD files we provide with Flow32-WIN, we advise not to use the raw data from the logger. Although the real time results are produced, the precision of the results is degraded to less than the expected accuracy of the sensors at low flow rates.

Instead we recommend that you record signals (Ch, Ah, Bh, Vin) from the Flow32, without the double precision internally. Then simply use the EXCEL spreadsheet, the post-processing program, to calculate energy balances with greater precision. This EXCEL recalculation will restore the precision to the results. See Flow32 manual for all the details on this process.

2.3.3 SGA2, SGA3 dX TC GAP SETUP

SGA2 and the SGA3 have one TC differential reading only (one pair), and therefore by design $Q_v=0$. However to maintain similar software support for all sensors, there are two readings taken on the same thermocouples, Ah, and an identical Bh reading. The signals are internally connected in the sensor. Nevertheless, one must enter something non-zero as the dX gap because a divide by zero would be the result (see the formula for Q_v). Instead, enter 1.0 mm as the default dX gap, and the usual sap flow calculation will work fine. The Flow32-WIN software will already have this entered as the default.

3.0 STEM HEAT BALANCE THEORY

This section of the manual familiarizes one with the fundamental energy balance method to measure sap flow and sap heat flux. The basic equations, the thermodynamics, and the calculation of the sap flow are all the same for this type of sensor, even though the construction details may vary slightly. As noted in Section 2.1, the Trunk gages use multiple pairs of differentially wired Thermocouples, and since the signals are averaged together electronically, we treat them all as one dT (the change in temperature) measurement when making the sap flow calculation. Microsensors SGA2, SGA3 and SGA5 have variations where only a single pair of TC measures the dT , and for compatibility the Ah and Bh cable wires are connected redundantly to the same TC. The general theory is the same and there are only a few considerations required when calculating the Q_v (vertical or axial heat conduction) for these three sensors. Please see SEC. 2.3.

3.1 Stem Heat Balance Basics

The SHB method requires a steady state and a constant energy input from the heater strip inside the gage body. Therefore the stem section must be insulated from changes in the environment. For the same reason, the gage time constant is limited from five minutes to an hour, depending on the flow rate and the stem size. The Dynamax loggers have a power down mode so that power is saved at night and the stem is preserved from overheating. During the power down mode and at the transitions to power on, the sap flow is not computed to maintain the accumulated flow accurately during this unbalanced transition.

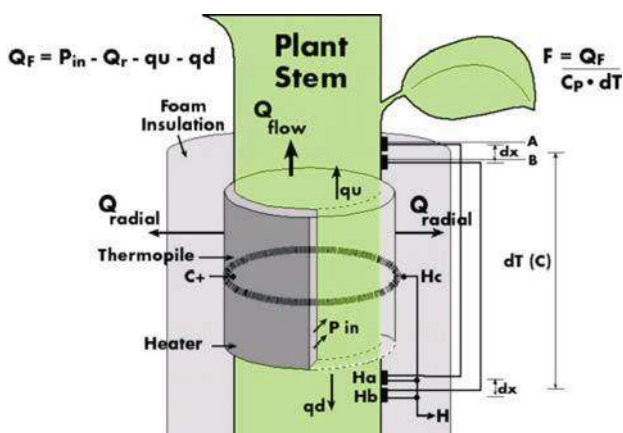

Figure 3.1 - Stem Gage Schematics

Fig. 3.1 shows a stem section and the possible components of heat flux, assuming no heat storage. The heater surrounds the stem under test and is powered by a DC supply with a fixed amount of heat, Q_h . Q_h is the equivalent to the power input to the stem from the heater, P_{in} . Q_r is the radial heat conducted through the gage to the ambient. Q_v , the vertical, or axial heat conduction through the stem has two components, Q_u and Q_d . By measuring P_{in} , Q_u , Q_d , and Q_r , the remainder, Q_f can be calculated. Q_f is the heat convection carried by the sap. After dividing by the specific heat of water and the sap temperature increase, the heat flux is converted directly to mass flow rate.

3.2 Energy Balance Equations

The energy balance is expressed as:

$$P_{in} = Q_r + Q_v + Q_f \text{ (W)} \quad \text{Equation (1)}$$

$$P_{in} = V^2 / R \text{ from Ohms Law.}$$

Fourier's Law describes the vertical conduction components:

$$Q_v = Q_u + Q_d$$

$$\text{Where } Q_u = K_{st} A \frac{dT_u}{dX}$$

$$Q_d = K_{st} A \frac{dT_d}{dX}$$

where K_{st} is the thermal conductivity of the stem (W/m^*K); A is the stem cross-sectional area (m^2); the temperature gradients are dT_u/dX (K/m) and dT_d/dX ; dX is the spacing between thermocouple junctions (m). One pair of thermocouples is above the heater and one pair is below the heater as shown on the schematic in Figure 3.2.

There are two differentially wired thermocouples both measuring the rise in sap temperature. Channel AH measures the difference in temperature A-Ha (mV). Channel BH measures the difference in temperature B-Hb (mV). By subtraction of these two signals:

$$BH - AH = (B - H_b) - (A - H_a) = (B - A) + (H_a - H_b) \quad (mV)$$

The result yields the two components of axial heat conduction out of the stem section, Q_u and Q_d (See Fig. 3.2). Since the distances separating the upper TC pair and lower TC pair are fixed by design for each particular gage to the same value, the components of Q_v are combined with a common denominator:

$$Q_v = K_{st} A (BH - AH) / dX * .040 \text{ mV/ } ^\circ\text{C}$$

The factor $.040 \text{ mV/}^\circ\text{C}$ converts the thermocouple differential signals to degrees C. K_{st} values, which is the thermal conductivity of the stem (W/m^*K), are given for varying stem conductivity: $0.42 \text{ W/m } ^\circ\text{K}$ (woody stem), 0.54 (herbaceous), and 0.28 (hollow).

To make proper use of the accumulator at low flow rates the algorithm tests first to see:

IF $0 \leq Q_f < 20 \% P_{in}$, AND IF $dT < dT_{MIN}$ (i.e. $dT_{MIN} = 0.75 \text{ } ^\circ\text{C}$ in a normal program default) then F is set to zero. However:

$dT_{MIN} = 1.0 \text{ } ^\circ\text{C}$ to $1.2 \text{ } ^\circ\text{C}$ for Large trees or plants that use water at night.

$dT_{MIN} = 1.5 \text{ } ^\circ\text{C}$ for SGA2 and SGA3 sensors that have the built-in positive temperature offset.

In the studies of small stems dT may be negative during the evening and may be at near zero for an entire evening. Negative and distorted flow rates are screened out using the first filter procedure.

The second phase of this filter is:

IF $Q_f < 0$

then F is set to $= -.00001 \text{ g/s}$, or -0.036 g/h , (CR10X based systems)

Forcing -0.036 g/h into the flow rate output provides a convenient flag value to be noted by the user. A flag is then set for a condition when it is necessary to inspect the data for reevaluation of the Ksh setting. The Ksh may not be set perfectly, and it is possible that a negative residual Q_f is computed, especially after sundown when a loss of heat storage gets interpreted as a negative Q_f for a few hours. By using the second phase of the low flow filter, the disruption of the accumulator is avoided. Minor negative excursions in Q_f are possible in circumstances of released heat storage in the stem and the gage jacket. During the evening hours when the heat storage is negative, caused by the ambient and gage dropping in temperature, a negative Q_f is commonly noted for a few hours after sunset. However these effects are normally short in duration and will not affect the overall performance of the Dynagage.

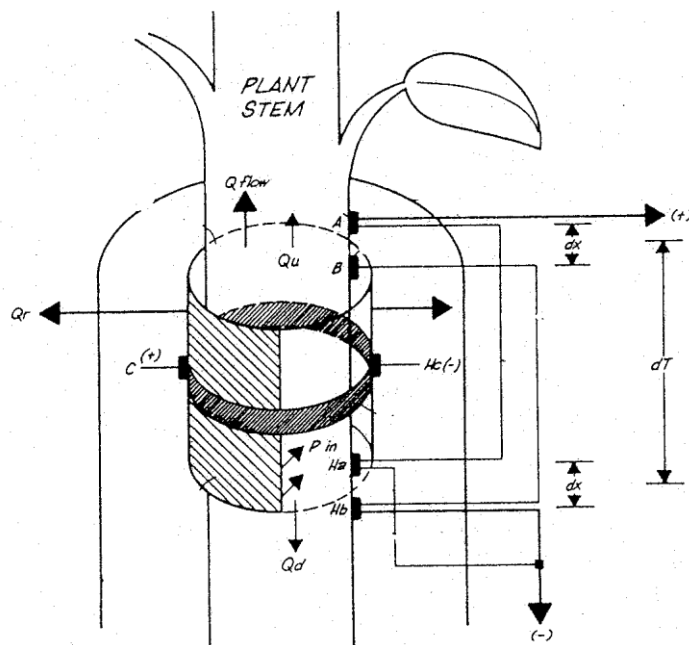

Figure 3.2 - Thermocouple and heater in Dynagage

3.3 Sap Thermodynamics (equations in back)

After solving equation (1) for Qf, the flow rate per unit of time is calculated from the equation for sap flow as described by Sakuratani (1981) and Baker - van Bavel (1987). This equation takes the residual of the energy balance in Watts, and converts it to a flow rate by dividing by the temperature increase of the sap and the heat capacity of water. Water is 99% of the sap content and it is safe to assume the heat capacity, Cp, is constant to all stems. It is understood that a Watt being 1 joule/second, will be converted to a flow rate (g/s) when divided by 4.186 joules/gram-deg C, and divided by the temperature increase in C.

$$F = (Pin - Qv - Qr) / Cp * dT \text{ (g/s)}$$

.....Equation (2)

In equation (2) the radial heat loss is computed in by:

$$Qr = Ksh * CH$$

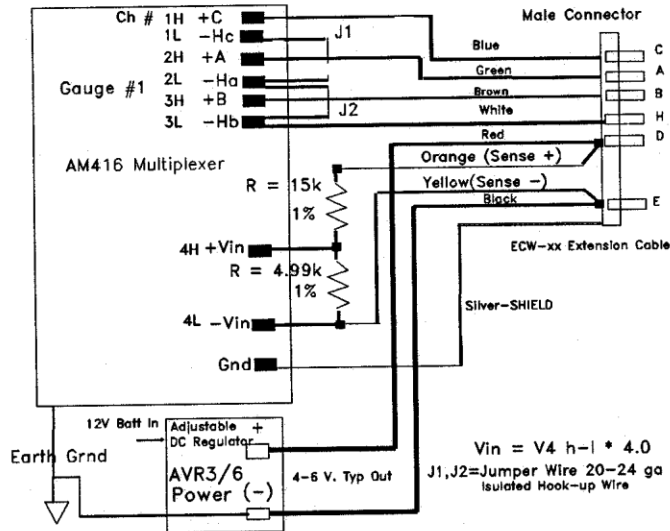

Figure 3.3 - Typical sensor – datalogger connections

Note: Vin = (4H - 4L) x multiplier (4.0) with the attenuator shown at the left, 5k Ohms/ 20k Ohms. This attenuates the input to a logger acceptable level. A 1/4 ratio is typical for Flow32.

Ksh is the thermal conductance constant for a particular gage installation explained in more detail in Section 3.4. Cp is the specific heat of water (4.186 J/g°C), and dT is the temperature increase of the sap. The temperature increase of the sap, dT, is measured in mV by averaging the AH and BH signals, and then converted to degrees C by dividing by the thermocouple temperature conversion constant. (Refer to back for equations)

$$dT = \frac{(AH + BH)/2 \text{ (mV)}}{.040 \text{ mV/C}} \quad \text{(C.)}$$

3.4 Apparent KSH Calculation

The thermodynamics equation of a heated fluid in an insulated cylindrical section at a constant temperature is included below to indicate the source of the Ksh computation and the effects of the radius of the cylinder's thermal conduction.

$$Q_r = 2 (\pi) K_{co} L (T_i - T_o) / \ln (r_i/r_o) \quad \text{Equation (3)}$$

Where K_{co} is the thermal conductivity of the cork substrate surrounding the heater. This is where the thermopile junctions, typically 8 to 12 in Dynagage construction, alternately measure the temperature adjacent to the heater and on the outside of the cork. L is the length of the cylinder. T_i and T_o are the inner and outer temperatures of the insulating cylinder. r_i is the inner radius, and r_o is the outer radius. For an installation of a fixed diameter, the Ksh represents all of the parameters and constants in equation (4), and relates the radial heat flux to the thermopile output CH by a constant factor as follows:

$$Q_r = K_{sh} (C - H_c)$$

Since the signal $(C - H_c)$, or simply CH, input to the datalogger is directly proportional to the temperature difference between inner and outer layers of the cork substrate and therefore the heat transfer radially. The sheath conductance is calculated when the user establishes a no-flow condition. The Ksh algorithm is derived from flow calculation steps, and it is computed every scan period, then averaged every 30 minutes. Although the Ksh calculation is computed during the day, and may have high values at high flow and negative values when Q_r heat is negative (inward heat flux), Ksh has no meaning except when the flow is zero. Details of zero flow and how to set are explained in the data logger manual.

The calculation for Ksh is determined by solving equation (1) when setting $Q_f = 0$ as follows:

$$P_{in} = Q_r + Q_v$$

and

$$Q_r = K_{sh} (CH) = P_{in} - Q_v$$

So after computing P_{in} and Q_v ,

$$K_{sh} = (P_{in} - Q_v) / (CH) \text{ (W/mV)} \quad \text{Equation (4)}$$

Apparent Ksh (the calculated value) is computed at all times for observation, however it is averaged automatically by Flow32, Flow2 and Flow4 programs in predawn conditions, when it is important to record the zero flow setting for Ksh. On most plants the user checks the first overnight Ksh at a predawn average, and then enters the value in the logger or spreadsheet sap flow computation program as the Ksh zero set point, or the Ksh setting in use. Before the first full night of data collection, the user needs to enter the other parameters required for solving equation 4 into the Setup program, if the real time values are to be recorded in the logger or displayed for the operator. The heater impedance, the stem area, the TC gap, and the thermal constant K_{st} , are required to compute P_{in} and Q_v , before a proper Ksh will be determined. Until that "Ksh Zero set run" is performed, any default value (for example 0.8) may be entered as the Ksh zero set. After the first Ksh value is determined, it is normal to make an additional adjustment the second or third predawn as the sensor conforms to a snug fit and adjusts to the shape of the stem.

The minimum Ksh will occur at the point when CH is at its peak value one to two hours before dawn. When the radial loss is at a maximum it is because the convection heat flux is at its minimum. Since crops and other plants grow, the Ksh will creep up as time goes on, noting the effect on the ratio of inner to outer diameter in equation 3. After several days it is wise to check the Ksh, and if it has drifted, recompute and reset the zero to obtain the best results. On large diameter trees, the Ksh setting is more

consistent when performed on an excised trunk or having the same diameter as the trunk. Additional discussion can be found in the data logger manual.

3.5 Low Flow Rates

There are two data filters advised for general logger programs to check the quality of the data, and reject flow computation at periods when the sensor signals are either below the minimum threshold or above the maximum flow capacity of the sensor. The low flow rate filter takes care of the initial conditions where dT approaches zero, or less than zero, and it can also flag the user when negative Q_f is computed, in the instance of a K_{sh} setting not being made at its minimum value. Generally the real time filtering is performed by the high capability loggers with the computational and logic capacity needed. With basic loggers, the logic and filtering is performed afterwards. When the vertical and radial heat fluxes are subtracted from the power input, Q_f is the remaining power carried by the sap. In the case of a zero flow rate on a very small stem; the temperature increases dT approaches zero. For these cases the flow may be grossly exaggerated with a minor residual Q_f . A true zero flow rate with accompanying dT of zero is rarely noticed on large plants, trees, or crop plants in a natural, growing condition. It takes only 3-4 grams per hour water flow to cause a positive dT on a 16 mm diameter plant.

To make proper use of the accumulator at low flow rates the algorithm tests first to see:

IF $0 \leq Q_f < 20\% P_{in}$, AND IF $dT < dT_{MIN}$ (i.e. $dT_{MIN} = 0.75\text{ C}$ in a normal program default)
then F is set to zero.

However:

$dT_{MIN} = 1.0\text{ C}$ to 1.2 C for Large trees or plants that use water at night.

$dT_{MIN} = 1.5\text{ C}$ for SGA2 and SGA3 sensors that have the built-in positive temperature offset.

In the studies of small stems dT may be negative during the evening and may be at near zero for an entire evening. Negative and distorted flow rates are screened out using the first filter procedure.

The second phase of this filter is:

IF $Q_f < 0$

then F is set to $= -0.00001\text{ g/s}$, or -0.036 g/h ,
(CR10X based systems)

Forcing -0.036 g/h into the flow rate output provides a convenient flag value to be noted by the user. A flag is then set for a condition when it is necessary to inspect the data for reevaluation of the K_{sh} setting. The K_{sh} may not be set perfectly, and it is possible that a negative residual Q_f is computed, especially after sundown when a loss of heat storage gets interpreted as a negative Q_f for a few hours. By using the second phase of the low flow filter, the disruption of the accumulator is avoided. Minor negative excursions in Q_f are possible in circumstances of released heat storage in the stem and the gage jacket. During the evening hours when the heat storage is negative, caused by the ambient and gage dropping in temperature, a negative Q_f is commonly noted for a few hours after sunset. However these effects are normally short in duration and will not affect the overall performance of the Dynagage.

Flow Rate Definition

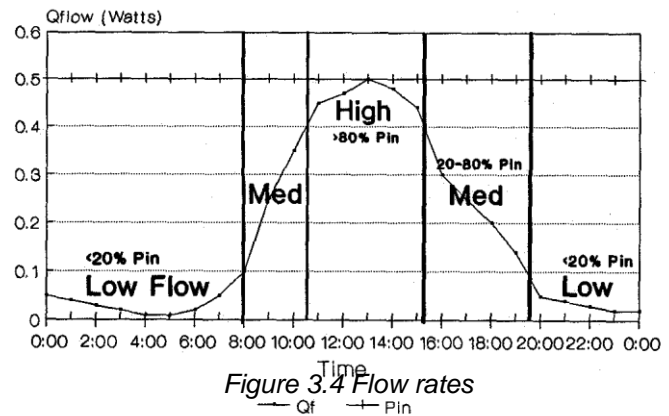

Figure 3.4 Flow rates

3.6 High Flow Rates

The temperature increase of the sap is a concern when flow rates are very large. It is clear that there is a hyperbolic dependence of the flow rate on the temperature difference dT . Since the minimum temperature corresponds to the maximum flow rate, the practical limitation of high flow rate is computed from an analysis of the instrument sensitivity and an estimate of the practical limits of thermal noise. The maximum gage flow rate can be determined by a signal analysis that compares the maximum output error due to the expected limits of input error for various situations, and then checking the maximum error against accuracy goals. This procedure is explained in this section with a specific example. In this way, the user can construct tighter or looser goals depending on the particular species or circumstances of operation. The analysis program support may then be adjusted to fit the specific research case.

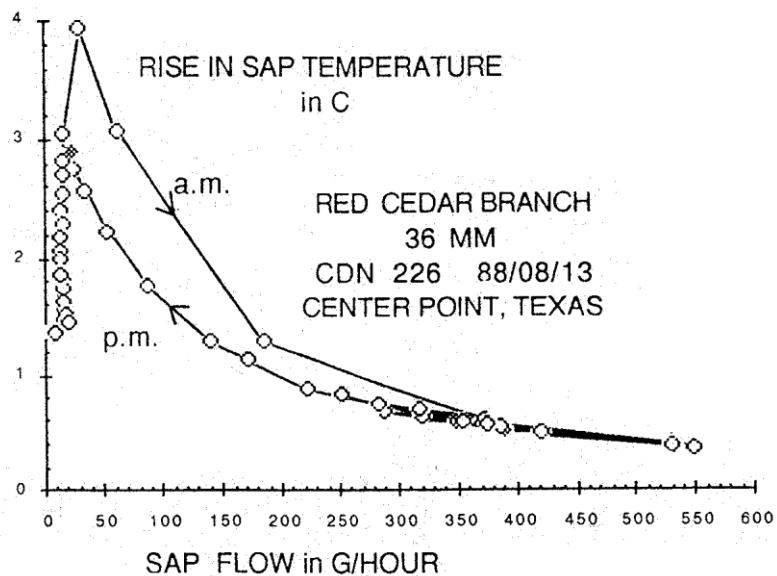

Figure 3.5 - Rise in Sap Temperature

The assumption of thermal sensing error in the sensors is that dT can be measured with about 0.1 C accuracy, and the accuracy of the datalogger is assumed to be no less than ± 1 microvolt (representing a 0.025 C error). For error analysis the $\pm dT$ of 0.1 C is superimposed on dT , and then the potential error can be expressed as a % of the total flow rate. If the potential error is over 30%, the flow data is judged to be unacceptable. The user may follow a procedure of disconnecting one of the power leads to a sensor in the field on a plant, and leaving the sensor attached to the logger while "passive" dT and thermopile readings are measured for a typical day of operation. If there is a very large dT swing due to the ambient temperature gradient where the sensor is installed, it can be measured and recorded with the other active sensors. By comparison, if a 0.25 C or greater passive dT is noted, compared to a typical 1.0 C reading on the active sensors, then there is a need to make adjustments in the sensor installation or the data set itself to correct for the gradient. An application note on this subject is in Section 4.8, and the article in Reference No 31 by Gutierrez (1994, Tree Physiology) explains the procedure as well. When the flow rate is exceptionally high, the Q_v component becomes very low, the radial flux approaches zero, and the sap absorbs almost all of the heat. Q_f greater than 80% of P_{in} characterizes these conditions. During the conditions of Q_f nearing P_{in} , the major determining variable left is the temperature increase, dT . Fig. 3.5 illustrates this point. As the flow increases, dT asymptotically approaches zero, as the trend in the afternoon indicates. As dT becomes smaller with increasing flow rates, thermal noise from radiation or other effects can cause a major exaggeration in flow. For example if the maximum power absorbed by the sap in Fig. 3.5 was at a temperature increase of 0.10 C, instead of 0.35 C, due to a -0.25 C error, the output of flow equation is 350% higher ($.35/.10 * F$), well in excess of a reliable flow-rate noise margin. The use of a high flow-rate filter prevents a distortion of the accumulated flow over those rates that are reasonable. For the sake of argument, an example of this distortion might be from afternoon sun shining directly on the trunk and gage without a shield installed (not a planned or correct usage).

Since maximum sap velocity is a convenient description of the problem, the output for the high flow rate filter stops at a maximum calculated rate depending on the stem diameter entered into the cross section area constant. A preset maximum velocity value of .042 cm/s, equivalent to a normalized sap velocity (Vol flow rate/stem area) of 152 cm/hr, is multiplied by the area:

$$F_{max} = V_{max} * A$$

If $F > F_{max}$,

Then set $F = F_{max}$, SET OVERFLOW FLAG IF AVAILABLE

In the example above, the maximum flow in a 35 mm tree trunk (9.6 cm^2) is computed and compared to the flow calculated. If in excess, the accumulator integrates flow at a rate of 1451 g/hr, F_{max} . Flow of sap over this calculated value may be encountered for brief periods, however the integrity of the accumulator is maintained. By an advanced user, a program change can be made to the (Flow32 or Flow2 or Fow4) DynaFlow Macro, and the V_{max} figure can be increased when the species under study is verified to be accurately measured.

At dT values under about .24 C, which is the maximum flow rate, and therefore an overflow condition is reached at this dT . The temperature stability of the Dynagage and the interconnections can be assumed to be no better than +/- 0.1 deg C. Therefore, the flow rate errors at $dT = 0.24 \text{ C}$, +/- 0.1 C, could indeed be significant if it were not prevented by the high flow rate filter. A flag may be set in software, depending on the sap flow system to indicate a possible error condition.

To prevent the thermal noise from becoming a large percentage of the measured signal, the user may increase the power to the heater. A 50% increase in power (increasing voltage 22%) may be performed and tested to check the increase in dT at maximum flow. A second increase of 50% may be necessary as the season progresses and leaf area increases. If the sap temperature increase in the morning goes beyond a safe limit, beyond 6-7 C, then the power down mode available on most systems should be used to cut off the heater power after sundown, and back on an hour or two before sunup.

Sections 4.8 and 4.9 contain guides and procedures to removing noise sources. Section 4 explains the correct methods of installation that reduce any possible measurement errors affecting flow rate computations.

4.0 DYNAGAGE INSTALLATION AND MAINTENANCE

The present product has been proven accurate and durable. It can be used over prolonged periods of time and installed on the stem, removed, and reinstalled. Nevertheless, it is a delicate piece of equipment and should be handled with care, particularly in installation and removal. Repairs to a damaged gage may not be practical.

4.1 Unpacking

Dynagages are shipped with the gage mounted on a short piece of dowel or packing tube, having the typical diameter for which the gage is designed. If the gage comes with a weather shield, it is installed around the gage. Before installing the gage the customer should verify that the gage has arrived in good condition. At the factory the instrument has been tested for mechanical and electrical integrity, and it has been checked for proper functioning as well.

To remove the dowel, do not push the dowel out. Instead, loosen the Velcro straps and open the insulating jacket at the vertical slit. Keep the slit open with a finger and gently remove the dowel.

4.2 Preparing Stems

First measure the stems to be prepared for sap flow monitoring to ensure that the diameter is within the range of the gage. Use a girth tape or caliper for the most reliable readings. Noting the installed height in the mechanical specifications, measure the girth at the midpoint for the gage position, record the diameter, and figure the sectional area (in cm²) for entering into the setup constant settings. Sections 4.7 and 4.8 explain the procedure if the fit of the gage must be changed to accommodate a larger or smaller diameter. The stems selected are ideal if they are free from petioles, leaves, large scars, or other irregularities. Record this in a worksheet for entering in software.

Application Note – Maize Douglas Fir & Succulents

All Plants transpire to some degree though the stem of the plant, especially well watered maize. To prevent a constant accumulation of this condensed water from affecting the gage readings, wrap a layer of thin plastic around the stalk and tape it in position. Then install the gage over the plastic wrap. The plastic used is the type to wrap food for refrigeration. This will keep your gage “fresh” as well. The plastic layer does not affect the overall gage performance.

Generally a few small branches or leaves are removed by cutting petioles flush with stem. The gage should not be put on until healing of the wound has occurred so as to prevent damage to the gage from plant sap. Roughness in healed leaf scars and accumulations of naturally occurring dead bark is removed by very light sanding with medium-fine sand paper (See Figure 4.1). Any sanding should be kept to a minimum. Species that have thin bark, less than 1 mm thickness, require little or no sanding at all. Species with thick layers of bark 2mm or more may require more sanding. The sanding should not penetrate through the live, green, cambium layer. Crops and herbaceous plants seldom require any sanding. It should be avoided if possible.

4.3 Preparing Trunks or Tree Branches

4.3.1 Sand Rough Stems

Since the temperature of the xylem, and heat flow into the xylem is key information, the installation requires a reasonably smooth stem. In general, the least amount of preparation is the best. If there is rough bark, loose bark, or heavy scar tissue, it should be smoothed with careful sanding. It is always best to select a part of the trunk that measures close to the median diameter (TYPICAL in mechanical specs, Section 2.1) of the gage, and is fairly free of irregularity. Make sure that installation is not close to the ground, avoiding trunks areas that have a graft mark.



Figure 4.1 - Sanding the stem

About 10 cm above and below the gage position, the trunk should be sanded briefly with medium-fine sand paper, removing the dead tissue, loose bark, and smoothing large petiole protuberances. For many conifers and most old oaks (quercus), this requires a rasp. Living cambium should not be visible (no green showing), not cut, nor damaged. Some species may only require minimal sanding, if the tree has a paper thin bark. In this way, no damage is done to the tree under study. For example most deciduous tree saplings, many fir trees, and the majority of fruit trees require no preparation other than cleaning the surface and removing a few small branches.

4.3.2 Check Fit on Trunk

If the tree under study is 3-5 mm less or 5-10 mm greater than the typical gage diameter (SGB35, SGB50, SGA100 only), the discussion in Section 4.4 and 4.5 explains the gage preparation. Moving up or down the trunk may make a better fit possible without modifying the gage diameter. Place the sensor O-rings to get a good idea of the fit.

4.3.3 Clean the Trunk and Apply Release Spray

Next, clean the trunk with a rag or sponge soaked with plenty of water and a bit of detergent to remove dust and grit as shown in fig. 4.3. The trunk should dry out for a few minutes. Canola release spray is supplied in easy to use spray bottle. Open the bottle and replace it with spray top. Spray the Canola release spray in two coats around the circumference of the trunk where the sensors go. Let the compound dry between coats. There should only be enough sprayed on to wet the surface. Store the spray for future installations or maintenance. Then let the solvent evaporate, which will take about five minutes. The residue is a release compound, which prevents the sensor sticking to the tree, and will aid installation. This procedure avoids the use of G4 directly on the stem, which has been found to cause "choking" of the cambium due to the layer of thick grease that is impervious to moisture and air. The "choking" looks like a narrowing and dying off of certain sensitive (young) conifers, olive trees and eucalyptus that need cambial gas exchange and cambial transpiration to grow properly.

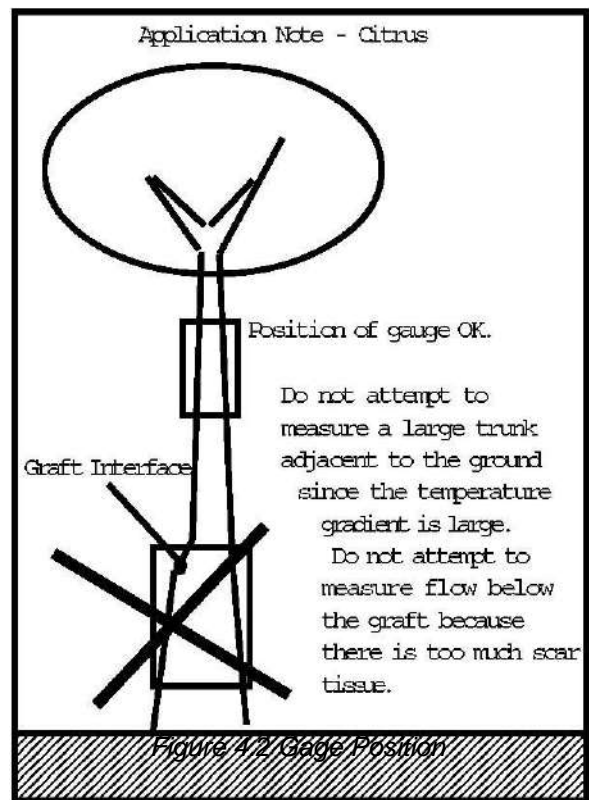



Figure - 4.3 Clean the trunk



Figure - 4.4 Canola Release Spray

4.3.4 Adventitious Root Prevention

Do your trees or vegetables grow adventitious roots? Plants such as tomato, peppers, sycamores and some other species will grow roots into the sensor if it is left on for more than 5-7 days. A long-term measurement period causes roots to penetrate the inside skin of the sensor, which will cause severe damage. By moving the sensor after each week this can be prevented. In addition, it is recommended that a coating of trifluralin (TFN), a well-known root growth inhibitor, be applied to the sensor coating in the recommended concentration to prevent the formation/ penetration of roots. Only a minute amount of TFN is actually required to prevent root intrusion into irrigation emitters, and so requires a similarly small concentration for this application. This special application is experimental, and may be requested from Dynamax when necessary.

4.4 Installing Gages

At this time one needs to record plant and sensor details, to be entered as parameters in sap flow calculation. Make sure to note the plant parameters to be recorded:

1. Make notes on the heater impedance found on the sensor serial number label.
2. Make the stem diameter measurement at the midpoint of the gage installation. Record this measurement for loading as a stem parameter into the software later.
3. Complete the sensor installation. Cables should be attached to the sensors during this step, and electrical tape should be wrapped around the connector interface when using the system outdoors. Make a record of the cable number corresponding to the sensor/plant.

Trunk gages should be installed in mid afternoon to take advantage of the diurnal shrinkage. Before installing on the plant, squeeze a small amount of G4 silicone insulating compound onto the sensor heater and inner insulation. This should be thoroughly rubbed on until it has a very thin layer on the inside of the sensor. Wipe off any excess with a paper towel. The purpose of this is to:

- Seal out moisture from penetrating inside of the sensor
- Prevent sensor thermocouple corrosion
- Aid expansion and contraction of the heater and gage

Estimates of how much compound to use:

10-16 mm diameter	.25 g
19-25 mm diameter	.5 g
35 mm diameter	1-2 g
50 mm diameter	2-3 g
70 - 100 mm diameter	4 g

One gram of compound is a bead about 1 cm long from the tube. Spread a thin layer of G4 on the inside of the Dynagage components including the heater element, just enough to coat the parts with a thin film. The sensor will feel a bit greasy and this should be enough to perform the functions above.

Steps:

1. Make sure that the correct end of the gage is up, that is toward the plant apex. **The sap flow direction is up when the cable connector points down.**
2. Then, open the gage wide enough to slip the jacket around the stem. This must be done very carefully to prevent the gage components from being dislocated or otherwise damaged. You will note that the heater is not flush on the right hand side of the gage.
3. Be sure the **heater strip is tucked inside the gage adjacent to the stem** as indicated in Fig. 4.5. The heater strip should completely encircle the stem at least once.
4. Close the Velcro straps in the middle of the gage tightly. Tighten the remaining straps very snugly.
5. Adjust the size of the insulation by adding insulation wedges to the open gap if necessary. Proper closing of the jacket is an essential step, because the thermo junctions A, B, Ha, and Hb must be in direct contact with the stem.
6. **Be careful not to abrade the exposed thermocouples**, since they may easily be damaged by rough bark.



Figure 4.5 - Heater strip position

7. At this time make sure to record the stem gage heater resistance and stem diameter if you have not done so yet. Make sure that the gage is firmly in place and cannot slide or twist with application of gentle force. A tree gage typically requires opening each strap in turn, and tightening it a second time to a strong, even pull over the entire insulation jacket. Attach the sensor cable to the gage connector, aligning the male terminals with the female socket.
10. Since 1998, cable leads and sensor leads have been provided with a rubber protection boot helping prevent damage in handling or movement. Pull the rubber boot aside, down the cable a few centimeters.

11. Then, **Wrap a short piece of electrical tape (usually a black vinyl tape) around the cable junction and stretch tightly around the interface.**
12. From the sensor side of the connector, slide the rubber boot over the taped junction.
1. Secure the cable with a nylon tie to the stem or to a ground stake so a tug on the cable cannot affect the gage. If the factory assembled the customers system, all cables and attenuators are already attached and tested. If not, and the customer needs to self-install, **and then see cable details.**

4.5 Install O-rings and Weather Shield

1. Install the lower o-ring and allow the **connector cable to fit between the vertical gap in the lower o-ring** as in Fig. 4.6. Tighten the Velcro strap over the cable.
2. Install the upper o-ring loosely, and raise or lower it to adjust without any gaps and for the height of the Aluminum bubble wrap. When positioned properly, the shield fits between the Velcro straps with about 1 cm room to spare. Shown in fig. 4.6. Tighten the upper Velcro strap securely.
3. Seal the upper o-rings and shield mating surfaces with a film of G4.
4. **If there are gaps in the stem - upper o-ring, apply Blue-Stick between the stem and the upper o-ring mating joint as if using caulk.**
5. Install Aluminum Bubble foil (supplied with sensors) below the Dynagage as shown in figure 4.7. Secure the shield firmly using tie-strap or tape.
6. Install a second weather shield (Aluminum bubble foil) over the Dynagage. Position the shield covering top half portion of the bottom weather shield like and cover the entire sensor. Secure firmly using tie-straps or tape both above and below, as shown in figure 4.7.
7. Secure aluminum top shield using a clear packing tape, or white PVC tape as shown in figure 4.8. Leave the bottom open for ventilation and reduce moisture build-up.
8. Wrap entire length of shield to itself so that it holds a cylindrical shape. Secure at one or more locations along its length as shown in Fig. 4.9. The shield keeps out water, and prevents radiation from affecting readings.

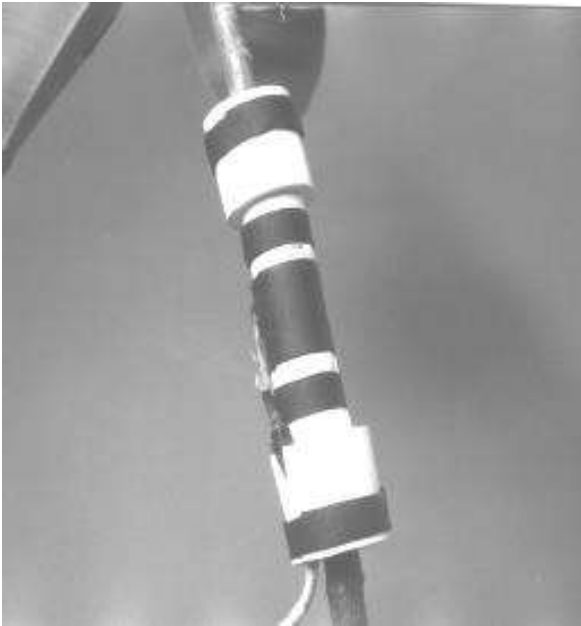

Figure 4.6 - O-rings installed



Figure 4.7 - Bubble foil Shield installation over sensor



Figure 4.8 - Sensor shield – Top



Figure 4.9 - Secure shield below the sensor

4.6 Shading Gauge And Trunk

To prevent sunlight from affecting the sensitive energy balance readings, the exposed trunk or stem extending below the gage must be shaded as shown in Fig. 4.10a and 4.10b.

- The easiest way to prepare the trunk or stem is to wrap layer of aluminum foil from the ground level up to the gage.
- Wrap more foil layers over the gage using a separate wrap for convenience of gage maintenance
- Accurate sap flow readings on branches and vines are aided by triple wrapping the segment below the gage as well as above with foil, since the sun may strike the branch at various times of the day

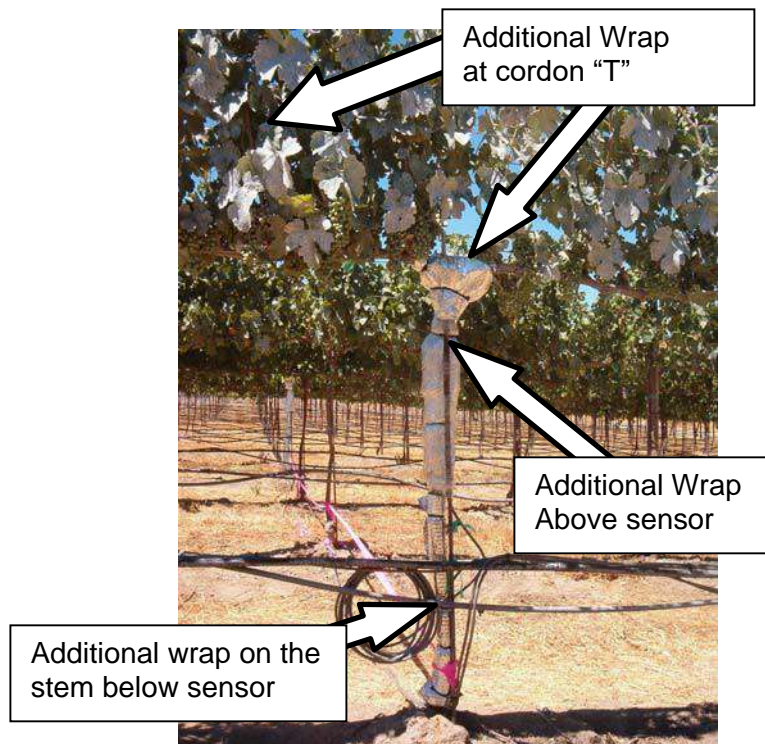

Figure 4.10a - Shading Gauge and Trunk

- The equalization of the stem to the ambient with aluminum foil will solve a common problem of the energy balance being upset by temperature gradients caused by the soil temperature vs. ambient, the sunlight on the stem, and rapid ambient changes. For this reason it is not recommended to add additional foam or fiberglass insulation below the sensor. More insulation will inhibit the ambient equalization. Likewise if the stem is shaded with a solid or reflective sunshade, it should allow for air movement around the stem. Researchers in very hot climates take the extra precaution of placing a reflective umbrella around the stem above the gage. This is useful in the instance of an open canopy, and in the case of high gradient greenhouse applications. References 29 by Devitt (1993), and Reference 31 by Gutierrez (1994) show that good results are obtained by using this installation method.

AVOID

Errors in dT Measurement

Understanding where thermal noise comes from is half of the answer. In the mornings, soil temperature exceeds the air temperature, as shown in Fig. 5.11. It may cause a (-) dT gradient in the sensor as warm sap enters a cooler stem. This gradient can cause temporary overestimates if the flow rate is high and the sensor is near the soil.

In the afternoon, the ambient air is at a higher temperature than the soil, causing downward heat flux. The sensor measures a higher dT due to a (+) dT gradient in the sensor. The afternoon problem is less since the air temperature falls gradually compared to the rise in the morning.



Figure 4.10b - Shading Gauge and Trunk

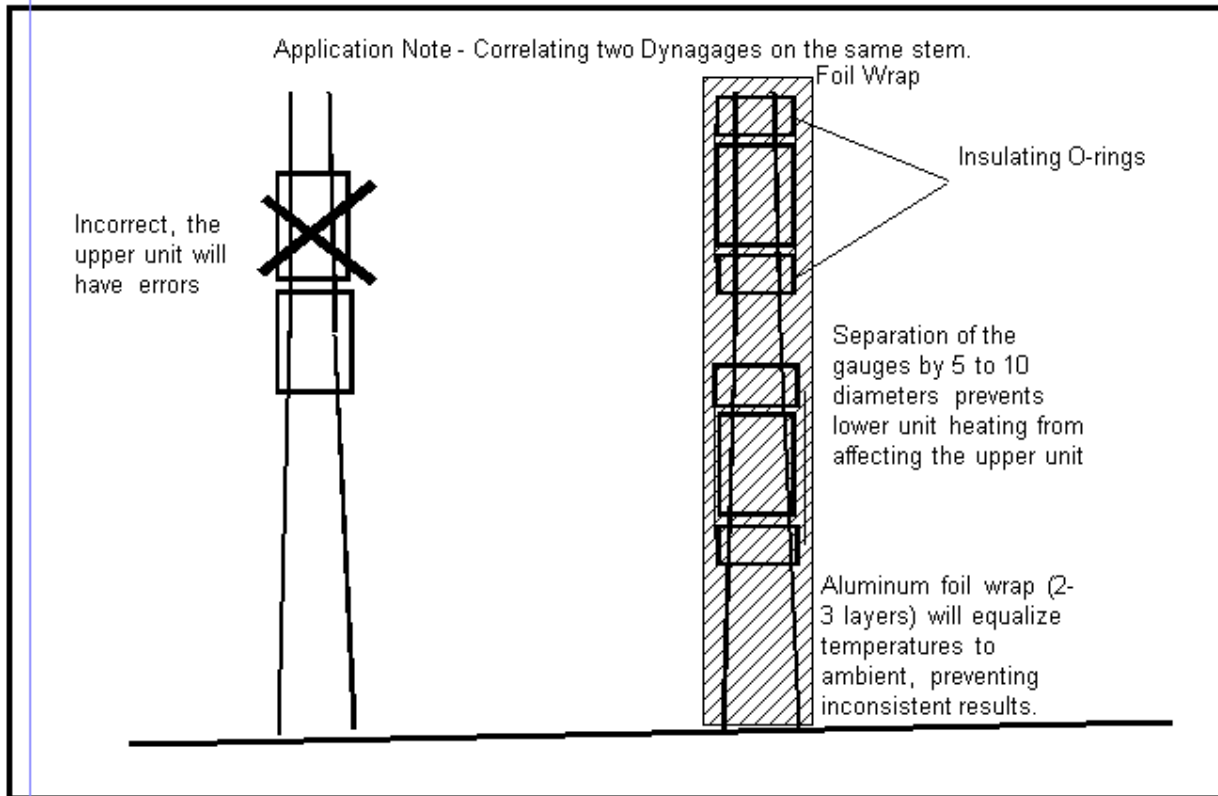

Application Note: Dual Dynagage Installation

4.6.1 Avoiding Errors in Sap Flow Data – Avoid Trunk Gages at Ground Level

Avoiding Errors in Installation

In the spring on 1992, Hort Science reported problems in measuring the sap flow in large peach trees (Schackel, 1992). Within this application section, the problems encountered are explained and solutions given. The sensor reported was used on a peach tree mounted at the base of the tree adjacent to the soil. By not having an incoming sap temperature equalized with the ambient, many anomalies were observed, chiefly the dT - sap temperature increase, being either zero, negative or close to zero, $0 < dT < 0.25$ C.

Others have reported no problems at high temperatures, as in Devitt (1993) in Hort Science 28(4): 320-322, with stems ranging from 29 to 45 mm in diameter. By comparison the result were obtained from many plants, and measurement runs of 2-3 days. The more data collected and accumulated, the better the results were. Combined errors over 30 runs were 1%, and some overestimations were cancelled by underestimations on other runs.

In contrast to Devitt, the data collection runs by Schackel were daily comparisons, and no automatic software filtering, was used to remove the data out of range of the sensor. In addition the data by Schackel was limited to one 50 mm sensor, including installations on trees 5 to 10 mm greater than the specified maximum diameter of the sensor (to 75 mm)

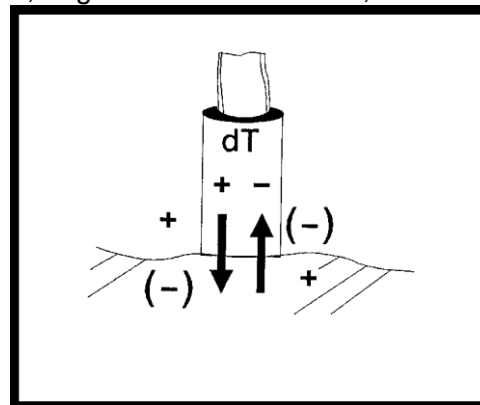

Figure 4.11 Tree temperature gradients are ambient temperature changes that occur daily.

One should never attempt to install sensors on stems larger than the gage since the heater strip will not evenly heat the sap, and lead to erroneous dT values. Anywhere from 15 to 30 mm gap in the heater in this case would cause that area to have uneven, erroneous dT recorded. The paper stated power was increased, however this procedure will not improve heat distribution.

In Section 4.9 is a summary of how to avoid the problems, how to avoid accumulated errors, and a workable solution to a temperature gradient that is simply unavoidable because of extreme conditions.

4.6.2 Testing for and Avoiding Unwanted Trunk Temperature Gradients

The temperature variation over a distance is the dTg/dY , where the distance dY is measured from the top to the bottom of the sensor cylinder. If this additional gradient, which we can call dTg , is superimposed on the sensing area, it may influence the readings of dT positively and negatively. In each system setup, it is recommended that one quantify the dTg at the time of the initial data collection.

- First one installs the sensors as described, and then turns off the AVR (DC) switch, to stop power to the sensor.
- To select only a few sensors, one may disconnect the heater lead from the terminal block supplying power to the selected sensor.
- Then log the regular dT and sensor signals for at least 24 hours.
- After inspecting the data, there will be fluctuations caused by a combination of the soil, water and air gradients.
- After an hour or more dT measurements greater than ± 0.25 C should be noted and the installation addressed.
- If the dTg causes dT to go negative in the morning by more than 0.25 C, up to -1.0 C as in the case of Schackel (1992), then the likely cause is the sensor is too close to the ground.

Making this conclusion assumes that the stem below the sensor is shaded, and the sensor is properly fitted. If the negative gradient shows up in the afternoon when the sun angle is on the trunk, a sensor mounted above the ground can have heated sap entering the sensor. This situation is remedied by shading the trunk, and equalizing the sap temperature with the ambient by aluminum foil.

When recording the non-heated sensors, one will note that the ambient also causes radial heat flux, Or, to go both negatively and positively depending on if the ambient is heating or cooling the trunk. In both cases, the Q_r values are computed correctly with daily sap flow results, since the absolute heat flux is established with a Ksh zero set factor during a thermally equilibrated predawn condition. That is, with a proper zero set value determined, one is continuously and automatically assessing radial heat exchange with environmentally induced gradients. This additional positive or negative heat transfer is therefore included in the energy balance equation. The same conclusion applies to small Q_v fluctuations one may note with non-heated sensors.

4.6.3 Correcting Unavoidable dT_g , Environmentally Induced Temp. Gradients

In very severe gradient environments, such as a greenhouse having little circulation compared to the natural condition, one may record the gradient by logging unheated sensors on one or two plants, and adjust the dT on heated sensors recorded simultaneously on a set of similar plants. The reference No 31 (Gutierrez, Fownes, Meinzer 1994) on this procedure shows a 10 % improvement in sap flow calculations when adjusting the dT with the gradient measurement on unheated plants. In this case readings in the afternoon showed that unheated sensors had a positive .5 C to .6 C gradient. Thus the sap flow calculated was lower than if the gradient were removed. By subtracting the gradient from the dT recorded on heated sensors, and then recalculating sap flow, a high degree ($r^2 = .94$) of hourly transpiration accuracy was obtained.

The researchers also verified the need for insulation by measuring the ambient gradients with unheated sensors. They noted that the plants having the trunk shielded and insulated did not have a significant problem. DT_g values from 0.1 to 0.25 C were recorded in the latter case. When the insulation below the sensor was removed, the gradient showed up as a problem, with dT_g measured at 0.5 to 0.6 C. These plants were small koa trees (*Acacia koa*) with open canopies, and trunks exposed to the sun periodically. Similarly they noted that when stem gages were installed on plants with closed canopies, coffee (*Coffea Arabica*) in this case, corrections to dT are unnecessary because the gradient fluctuations are likely to be near zero.

4.7 Expanding Gage Size

If the trunk section under study is larger than the typical diameter for the gage (for example 40-45 mm for the SGA35, or 60-65 mm for the SGA50), rather than stretching the rubber insulation and deforming the sensor permanently, place a 2-3 cm wide insulator wedge into the vertical gap before closing the gage straps. Insulation wedges, the black foam rubber sections, are provided with the trunk gages for this purpose. More strips are available upon request.

Stem gages from 10 to 19 mm in diameter may also be expanded by 3-5 mm by placing a 1-2 cm wide insulator wedge into the gap between the insulation jacket. A wedge can be supplied for each gage by request. Most rapid crop diameter growth can be accommodated for several weeks with additional wedges.

4.8 Reducing Gage Size

After a trial installation of the gage on the trunk, check the fit of the insulation. If the gage is loose and the insulation cannot be closed completely, adjustment of the jacket size is possible. If the trunk section is 2-5 mm smaller than the typical diameter of the gage (for example, 30-33 mm for SGB35, or 45-48 mm for the SGB50), the rubber insulation will require a minor modification. Mark the insulation with a vertical line 2 cm from the lip of the insulation. Using a sharp scalpel or sharp pair of scissors, a radial section 1-2 cm wide is cut from the insulation parallel to the vertical lip. The cut must avoid the heater strip or the cork annulus. When using a blade, place cardboard or other protection between the insulation to be cut and the exposed heater strip before making an incision. The cutout section can be put aside for future use on another tree, or for when the tree grows. Seal the new cut with a small amount of G4 silicone compound.

4.9 Guides to Removing Noise Sources - Avoiding Errors in Data

After the sensitivity for noise is understood, the procedures for discovering and preventing error or noise sources become well defined. Precautions must be taken by the user to prevent thermal noise, and secondly, electrical noise sources must be shielded or removed with proper grounding techniques. The recommended loggers are designed and tested to have low electrical noise within the system design.

It is easier to follow the checklist of the following items, and **prepare each installation with all of the precautions**, than it is to discover one by one that all of these noise sources are affecting your readings and causing a problem, and solving each one in turn. All of the precautions possible must be taken as listed below. The exclusion of outside heating from the sun and from large temperature gradients at the base of the plant solves many of the potential problems with thermal noise. Clearly a solid thermal contact is a primary concern, as well as the exclusion of water from the sensor.

THERMAL Action / Result

Remove excess bark and clean stem. Wipe with clean rag to check. Dirt and dead cork impede temperature sensing. Install weather shield and PVC shield. Seal out moisture at weather shield and seal mating points using G4 silicone compound or pruning sealer wax.

Mount gage temperature sensors away from scars, petiole nodes, graft marks. In large trees with short trunks, use branch measurement to avoid ground-heating effects. Perform weekly maintenance on gage, described in maintenance schedule. When encountering moisture buildup from cuticular transpiration or high humidity, wrap a plastic food wrap around the stem first, secure it, and then install the sensor. This procedure prevents sap and condensation intrusion into the sensor body.

Install heater securely, using approved canola oil release application. Wrap layers of Aluminum foil around exposed trunks and stems especially from gage to ground level. Shade plant pots from sun. Cover soil around potted plants with foil to reflect sunlight. Shade large exposed trunks below gage, and cover with Aluminum foil. Install sensor in the mid afternoon at the minimum plant diameter. Check heater for fit against stem.

Electrical

Connect power grounds and chassis ground together at one Common Earth Ground Point. Removes ground loop noise.

Connect Common Ground Point to Earth Ground To remove induced More to shunt hazardous lightning charges to ground, away from chassis.

Inside environmental chambers:

Connect a ground lead to the plant stem. The plant canopy acts as an antenna, picking up induced electromagnetic interference from the high voltage sources and conducting noise to the sensor leads.

Use crimp connectors on power leads. Shielded cable - shield lead connected to the ground.

Remove induced offset noise, ground bias noise

Measure Vin at gage, not at source of power

Thermal

Wrap exposed trunk, branch or stem with foil

Remove gradients associated with extreme temperatures. Shade stem and sensor.

Verification

Turn on power and observe “instantaneous” voltage changes on dT, AH or BH. If no change, then no ground noise.

Verify with ohmmeter - less than .5 Ohm resistance from chassis to grounded pipe or wall receptacle safety ground.

Looking at short term, one minute readings, there should be no major periodic oscillations.

Pull on wires and Physical inspection.

Standard with differential voltage measurement provided by recommended loggers. Check the 50/60 Hz rejection setting depending on your country.

Use cables containing sense leads separate from the power leads provided. Four wire measurement of voltage.

Verification

Disconnect the heater power, or turn off the AVRDC power. Observe the dT signal 24 hours to ensure environmental gradients are minimal (< 0.25C)

Disconnect the heater power, or turn off the AVRDC power. Observe the dT signal 24 hours to ensure environmental gradients are minimal (<0.25C)

4.10 WARNING - Prevent Gage Damage - Gage Maintenance

The introduction into the stem flow gage of solvents, non-silicone based grease, or caustic aqueous solutions voids the warranty. Users are required to take precautions against moisture or abrasion at all times. The cable connector must be carefully wrapped with electrical tape and sealed to prevent water from creating an electrolytic short between Vin and the thermopile wires, or thermocouple wires. If there are any doubts about wholesale moisture in the gage, turn off the heater supply immediately, and remove the gage for inspection and drying.

When cleaning excess G4 compound, acetone paint thinner is the only solvent approved for use on gages. Apply the solvent sparingly to a soft cloth or paper towel and wipe excess grease away. Dirt and sap collection inside the sensor can be removed with detergent and water by using a soft toothbrush or soft cloth soaked in a detergent solution.

4.11 CAUTION - Check Gages Weekly - Gage Maintenance

GAGES SHOULD BE CHECKED WEEKLY DUE TO RAPID GROWTH OF SOME PLANTS. IN THE CASE OF RAPID GROWTH, THE HEATERS MUST BE LOOSENED TO ACCOMMODATE EXPANDING GIRTH. IT IS NECESSARY TO CHECK FOR SAP ACCUMULATION AND TO CLEAN THE SENSORS.



Figure 4.12 Sensor Maintenance

Loosen the Velcro straps and inspect the cork sheath area for excessive corrosion, sap accumulations and any other obvious problems with the stem or gage as shown in Fig.

5.12. If everything is in order, tighten the gage back into its original position with a firm pull on the Velcro straps. Check the Ksh setting and reenter the proper value into the program settings.

If the gage has collected dirt, sap or salts, take corrective action by cleaning the gage with a damp cloth. If the stem is “sweating”, do not be concerned. Sometimes condensate appears as a wet spot on the stem, and moisture will drain down the gage. In the case of a saturated gage, for example a succulent monocot, a single wrap of plastic film can be installed around the stem and prevent moisture buildup. See the Maize application note in Section 5.2

If the plant is oozing sap, it should be allowed to heal. The stem should be cleaned with water and dried. Then allow the stem to heal before installing gages again. Upon installation, coat the sensor sparingly with G4 silicone insulating compound. On small bushes or trees where branches are pruned, it is helpful to have this process of sealing performed several days prior to gage set up.

The SGA100 model Dynagage is equipped with a purging tube that can be used to remove accumulated condensation by forcing nitrogen or dry air into the space between the upper thermocouple strip and the heater. The method is very useful when extended sap flow measurement periods are desired, and the humid environment combined with the temperature gradients above the heater are conducive to condensation. This method saves time and does not require the gage to be removed.

After applying pressurized nitrogen or dry air at a very slow rate for 30 minutes, the gage must be allowed to reach equilibrium before making readings.

4.12 Expanding Girth

Usually the gages will expand/contract with the stem diurnally. However, over time the heater can be trapped or stuck by sap to the stem, especially if Canola oil (TFE1) release compound was not applied to the stem, or if G4 silicone compound was not applied to the heater. In this case, periodically loosening the straps and checking the fit of the gage can avoid breakage.

After an extended period of plant growth, if the heater does not encircle the stem completely, then it is time to move up to a larger gage or raise the gage higher on the stem. Since the stem cross section will not have sufficiently thorough and even heating when the heater does not encircle the stem, the resulting inconsistent dT readings will cause erratic and unreliable results.

4.13 Bench Testing Gage and Fault Diagnosis – Maintenance

Q: I have readings of -9999, what's wrong?

A: As with any delicate instrument, there is the possibility of wear and tear on the components causing breakage. Usually the signals at the data logger will indicate all -99999, or provide the outside range indicator when there is an open circuit in a connection. The best diagnostic procedure is to first check the wiring to the data logger and then the connecting cable. Physically inspecting the wires to the screw terminals and giving them a firm tug will confirm the soundness of the lead wire connection.

Q: How do I check the Dynagage cable?

A: The connecting cable can be tested by a Volt-Ohm Meter (VOM). Remove the gage from the connecting cable. Place the VOM in the resistance mode (1k Ohm or less). Attach one VOM test lead to each male prong on the end of the cable, and then touch the other end of the exposed cable wire that corresponds to the male prong. Note that the orange and red leads (V_{in} (+) and V_{sense} (+)) in the ECW-xx cables, eight conductor extensions, are connected together at the connector as well as the black and yellow leads (V_{in} (-) and V_{sense} (-)). The resistance from the connector to the free end of the cable should be .2 to 2.5 Ohms depending on the length of the cable.

Q: How do I diagnose a Dynagage problem? First how do I check the heater?

A: A digital VOM on the 200-Ohm setting is the best for verifying the internal resistances. Touch the two probes of the VOM firmly to the female D and E terminals. There are letters embossed on the connector to identify the correct leads. D and E are the heater leads, and the resistance should equal the value given on the serial number tag within +/- 1 unit of the least significant digit. If there is an open circuit, infinite impedance, then the heater is broken. Send the unit back to the factory for replacement if that is the only problem.

Q: How do I check the thermocouples (C terminal reference to H)?

A: Next, test the C and H terminals. C-H is the radial thermopile and its resistance should be between .9 and 3.6 ohms, depending on the gage size. If this circuit is open, there is a break in the thermopile wire.

Q: How Do I check the thermocouples A and B with reference to H?

A: The resistance at between A and H should be about 1/3 to 1/2 of the thermopile reading, between 0.4 and 1.7 Ohms. Finally check between the B and H terminals, which should also be about 0.4 to 1.7 Ohms. If either of the A-H or B-H wires are open, factory repair is possible. If you are not sure of getting a firm contact with the female terminals, insert a resistor lead wire or any other solid wire into the socket pins desired and then measure the resistances. Send the unit back to Dynamax with a description of your test results if there is a confirmed problem. Generally, if only one of the above problems is found, the gage can be effectively repaired. If more than one problem is discovered, it is usually because of a burned up unit caused by shorting of several electrical components by complete saturation in water during power-on. There is usually no economical repair possible, and the warranty is voided anyway.

4.14 Annual Maintenance

If sensors are used continuously in the field for a year or more, check the coating on the inside and outer part of the sensor. If the white insulation is cracked or has holes in it, the sensor should be resealed. The distributor or supplier may perform this service for you, by resealing with a silicone sealer, and repainting with factory supplied white latex paint.

If the cork layer is cracked, has lost its glossy finish, or shows obvious corrosion on the exposed wiring, then the wiring and circuit sealer should be refinished. Please consult with your factory representative for a return and refurbishment. Both of these procedures are performed at the factory for a minimal fee, and will include repairing any holes, broken thermocouple wire, as well as resealing. Further maintenance and weekly steps are explained further in Section 4.10 - 4.11.

4.15 Limited Warranty and Repair Policy

Dynamax, Inc. warrants to the original purchaser that this product, Dynagage, is free of defects in material and workmanship for a period of One (1) Year from the date of product shipment to customer. If defective, the product must be returned to us, freight prepaid, to the address shown below and it will be replaced, by us, at no charge. Any product which malfunctions and is returned to us within the warranty period will be repaired or replaced (our option) at no charge, provided it has not been subjected to abuse and has been installed with reasonable care according to the stated instructions.

Advertising claims made by us represent our honest opinion of the qualities and features offered by the products described. Although we believe that the products are well established and perform suitably, we must leave to the purchaser the responsibility to determine whether the product ordered will fulfill his or her needs. In no event shall Dynamax, Inc. be liable for consequential damages of any kind, unless specifically excluded by law. It is up to the purchaser to determine the suitability and reliability of this product for his particular application. Dynamax, Inc. shall not be liable for consequential, incidental, or special charges.

No person is authorized to make any verbal or written representations concerning this product and we disclaim any responsibility for any such representations. Dynamax, Inc. assumes no liability for customer assistance, infringements of patents or copyrights arising from the use of this product. Dynamax Inc does not warrant or represent that any license, either express or implied, is granted under any patent right, copyright, or other intellectual property right of Dynamax Inc relating to this product or process of manufacture.

Any product that is not covered by the above warranties will be repaired at a cost commensurate with the work required. Repair charges shall not exceed \$75.00 without prior approval. This warranty gives you specific legal rights and you may also have other rights that vary from state to state within the U.S.A. All sales are made subject to the terms stated above. If these terms are not acceptable to the purchaser, then he should return this product in the original packaging. Retention of this product by the customer shall constitute an agreement that he has read and accepts the terms of this Limited Warranty.

Dynamax, Inc.
Service Department
10808 Fallstone, Suite 350
Houston, TX, 77099 USA
Tel. 281-564-5100
Toll Free in US & Canada
1-888-396-2628