

INSTRUCTION MANUAL

Silicon Pyranometer

# ML-01

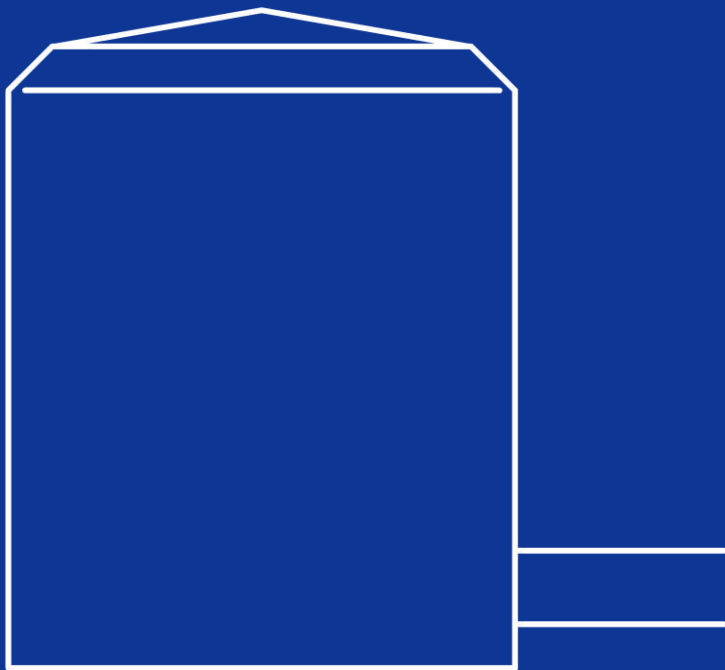

EKO

# 1. Index

<b>1. Index</b>	<b>1</b>
<b>2. Important User Information</b>	<b>2</b>
2-1. Contact Information	2
2-2. Warranty and Liability	2
2-3. About Instruction Manual	3
2-4. Environment	3
2-5. CE Declaration	4
<b>3. Safety Information</b>	<b>5</b>
3-1. WARNING/CAUTION	5
<b>4. Introduction</b>	<b>6</b>
4-1. Main Features	6
4-2. Package Contents	6
<b>5. Getting Started</b>	<b>7</b>
5-1. Parts Name and Descriptions	7
5-2. Attaching the Leveling Plate (Optional)	8
5-3. Setup	9
5-4. Cable Connection	11
5-5. Measurement	12
<b>6. Maintenance &amp; Troubleshooting</b>	<b>13</b>
6-1. Maintenance	13
6-2. Calibration Method	14
6-3. Troubleshooting	14
<b>7. Specification</b>	<b>15</b>
7-1. Main Unit	15
7-2. Cables	16
7-3. Dimensions	16
7-4. Accessories List	17
<b>APPENDIX</b>	<b>18</b>
A-1. Spectral & Directional Response Characteristics	18
A-2. Traceability	18

## 2. Important User Information

Thank you for using EKO Products

Make sure to read this instruction manual thoroughly and to understand the contents before starting to operate the instrument. Keep this manual at safe and handy place for whenever it is needed.

For any questions, please contact us at one of the EKO offices given below:

---

---

### 2-1. Contact Information

#### EKO INSTRUMENTS CO., LTD.

##### Asia, Oceania Region

www.eko.co.jp	EKO INSTRUMENTS Co., Ltd.	Tel: +81 (3) 3469-6711
info@eko.co.jp	1-21-8 Hatagaya, Shibuya-ku	Fax: +81 (3) 3469-6719
	Tokyo, 151-0072 Japan	

---

##### Europe, Middle East, Africa, South America Region

www.eko-eu.com	EKO INSTRUMENTS Europe B.V.	Tel: +31 (0)70 3050117
info@eko-eu.com	Lulofsstraat 55, Unit 32,	Fax: +31 (0)70 3840607
	2521 AL Den Haag, The Netherlands	

---

##### North America Region

www.eko-usa.com	EKO INSTRUMENTS USA Inc.	Tel: +1 408-977-7751
info@eko-usa.com	95 South Market Street, Suite 300	Fax: +1 408-977-7741
	San Jose, CA 95113 USA	

---

---

---

### 2-2. Warranty and Liability

For warranty terms and conditions, contact EKO or your distributor for further details.

EKO guarantees that the product delivered to customer has been verified, checked and tested to ensure that the product meets the appropriate specifications. The product warranty is valid only if the product has been installed and used according to the directives provided in this instruction manual.

In case of any manufacturing defect, the product will be repaired or replaced under warranty. However, the warranty does not apply if:

- Any modification or repair was done by any person or organization other than EKO service personnel.
- The damage or defect is caused by not respecting the instructions of use as given on the product brochure or the instruction manual.

---

---

## 2-3. About Instruction Manual

Copy Rights Reserved by EKO INSTRUMENTS CO., LTD. Making copies of whole or parts of this document without permission from EKO is prohibited.

This manual was issued: 2016/09/26

Version Number: 6

---

---

## 2-4. Environment

### 1. WEEE Directive 2002/96/EC (Waste Electrical and Electronic Equipment)

This product is not subjected to WEEE Directive 2002/96/EC however it should not be mixed with general household waste. For proper treatment, recovery and recycling, please take this product(s) to designated collection points.

Disposing of this product correctly will help save valuable resources and prevent any potential negative effects on human health and the environment, which could otherwise arise from inappropriate waste handling.

### 2. RoHS Directive 2002/95/EC

EKO Instruments has completed a comprehensive evaluation of its product range to ensure compliance with RoHS Directive 2002/95/EC regarding maximum concentration values for substances. As a result all products are manufactured using raw materials that do not contain any of the restricted substances referred to in the RoHS Directive 2002/95/EC at concentration levels in excess of those permitted under the RoHS Directive 2002/95/EC, or up to levels allowed in excess of these concentrations by the Annex to the RoHS Directive 2002/95/EC.

---

## 2-5. CE Declaration



IMPORTANT USER INFORMATION

---



### DECLARATION OF CONFORMITY

We: EKO INSTRUMENTS CO., LTD  
1-21-8 Hatagaya Shibuya-ku, Tokyo  
151-0072 JAPAN

Declare under our sole responsibility that the product:

Product Name: Silicon Pyranometer  
Model No.: ML-01

To which this declaration relates is in conformity with the following harmonized standards of other normative documents:

Harmonized standards:

EN 61326-1:2006 Class B (Emission)  
EN 61326-1:2006 (Immunity)

Following the provisions of the directive:

EMC-directive : 89/336/EEC  
Amendment to the above directive:93/68/EEC

Date: JUN. 07, 2013

Position of Authorized Signatory: Deputy General Manager of Quality Assurance Dept.

Name of Authorized Signatory: Shuji Yoshida

Signature of Authorized Signatory: 

## 3. Safety Information

EKO Products are designed and manufactured with consideration for safety; however, please make sure to read and understand this instruction manual thoroughly to be able to operate the instrument safely in the correct manner.



### WARNING CAUTION

Attention to user; pay attention to the instructions given on the instruction manual with this sign.



### 3-1. WARNING/CAUTION

#### 1. Setup

When installing ML-01 use a proper base to mount the ML-01 with attached bolts and nuts. If the mounting plate and/or mast do not have enough strength, it can break and lead to unexpected accidents and/or injury due to strong wind or earthquake.

#### 2. Resin Diffuser

Giving strong impact to the resin diffuser may cause damage to the sensor. To clean the resin diffuser, use soft cloth without using any organic solvent, such as alcohol.

## 4. Introduction

The ML-01 is an industrial grade solar sensor made for Performance ratio measurements at PV sites as well as the wide applications of the irradiance measurement in the meteorological, agricultural and environmental studies. The compact dimensions of the sensor body make it easy to integrate within any application. For mounting the sensor in a horizontal position, an optional mounting plate with spirit level and leveling feet is available.

The Silicon detector with UV resistant diffuser will give a proper cosine response to the incoming radiation also at low solar elevation angles. This shape also minimizes soiling effects which could alter the quality of the measurement.

The ML-01 Si-Photodiode sensor is the link between reference cells and broadband thermopile pyranometers. Compared to the reference cells, it has a proper cosine response and it is more compact. Moreover, it also benefits from the same characteristics as a PV module (response time, spectral and temperature response).

---

### 4-1. Main Features

#### 1. Excellent Characteristics

ML-01 has excellent cosine response characteristics due to an enhanced diffuser detector construction. The detector temperature dependency of 0.15%/°C is equivalent to the temperature characteristics of Si-PV modules. The spectral response and time response function are equivalent to PV modules.

#### 2. Small and Light Weight

Very small in size and weight (φ22x28.5mm, 30g) make it easy to adapt to a PV system. ML-01 is most suitable for multi-point measurements of irradiance and illuminance distribution measurements.

---

### 4-2. Package Contents

Check the package contents first; if any missing item or damage is noticed, please contact EKO immediately.

Table 4-1. Package Contents

Standard Items	Qty.	Remarks
Sensor	1	With cable already attached to the sensor
Leveling Plate (Optional)	1	Sensor Mounting Screws (M2x6mm, 3pcs & extra 3pcs for spare) Leveling Screws(Bolts: M5x20mm, 3pcs) Fixing bolts (Bolts: M6x50mm, 2pcs, Washers: M6, 4pcs, Nuts: M6, 2pcs)
Calibration Certificate	1	
Quick Start Guide	1	

# 5. Getting Started

## 5-1. Parts Name and Descriptions

Each part name and its main function are described below.

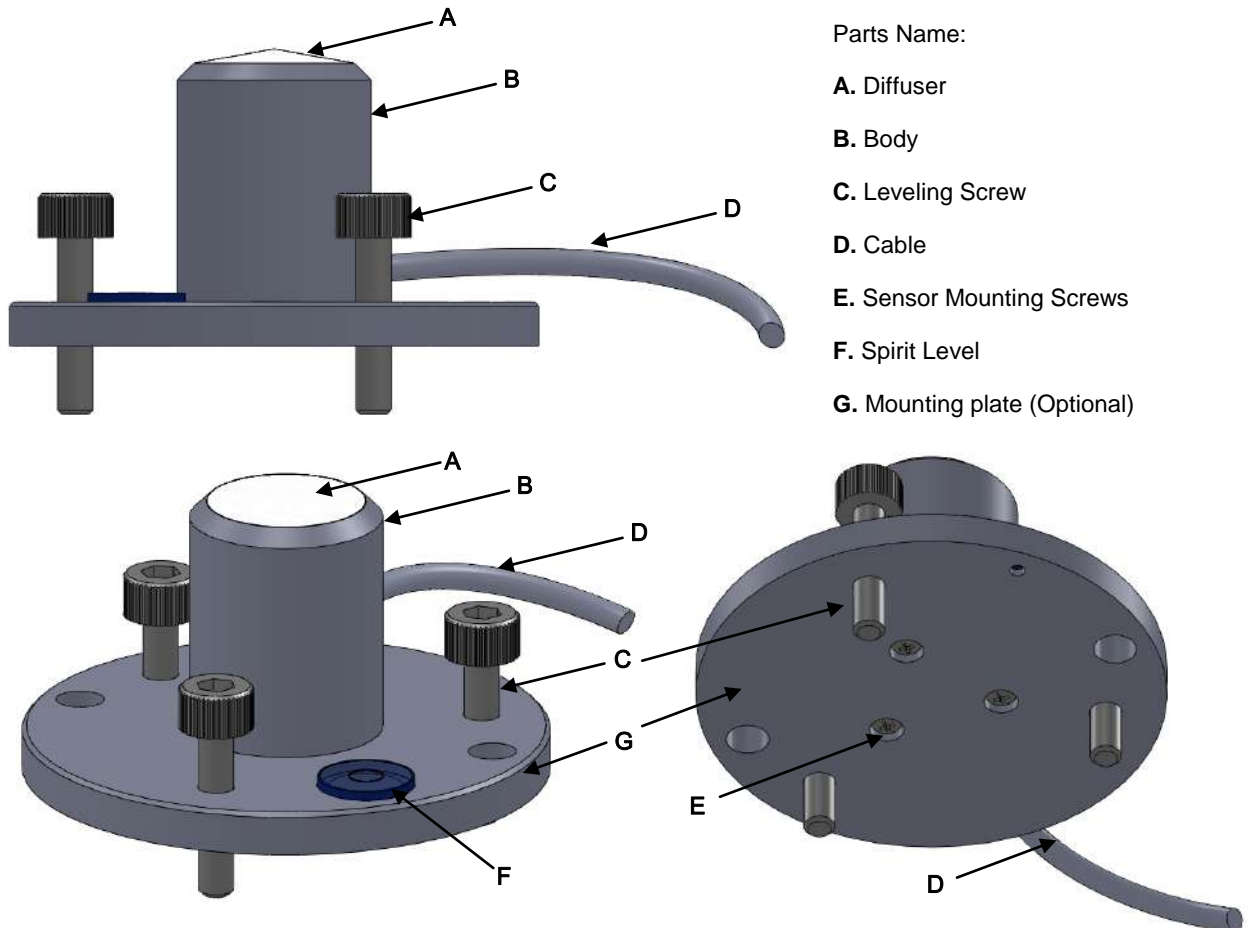

Figure 5-1. Parts Name and Descriptions

### 1. Diffuser

The special diffuser design gives a proper cosine response and reduces the effects of soiling, remaining water and dust. A durable UV resistant resin is used to perform reliable measurements over time.

### 2. Body and Spirit Level (Leveling Plate)

ML-01 can be combined with an optional mounting plate with spirit level for leveling and mounting the instrument in a horizontal position.

### 3. Signal Cable

ML-01 comes with a sensor signal cable which is already attached and can be used right away. At the end of signal cable has either a pin terminal for easier connection to measuring instruments such as data logger.

Standard length of the signal cable is 5m; other lengths (10m, 30m, 50m) are available on request.

---

## 5-2. Attaching the Leveling Plate (Optional)

If the optional Leveling Plate is used, attach it to the sensor as shown below using attached 3 screws securely.

Phillips (plus) screwdriver (#0) is required for the M2 mounting screws.

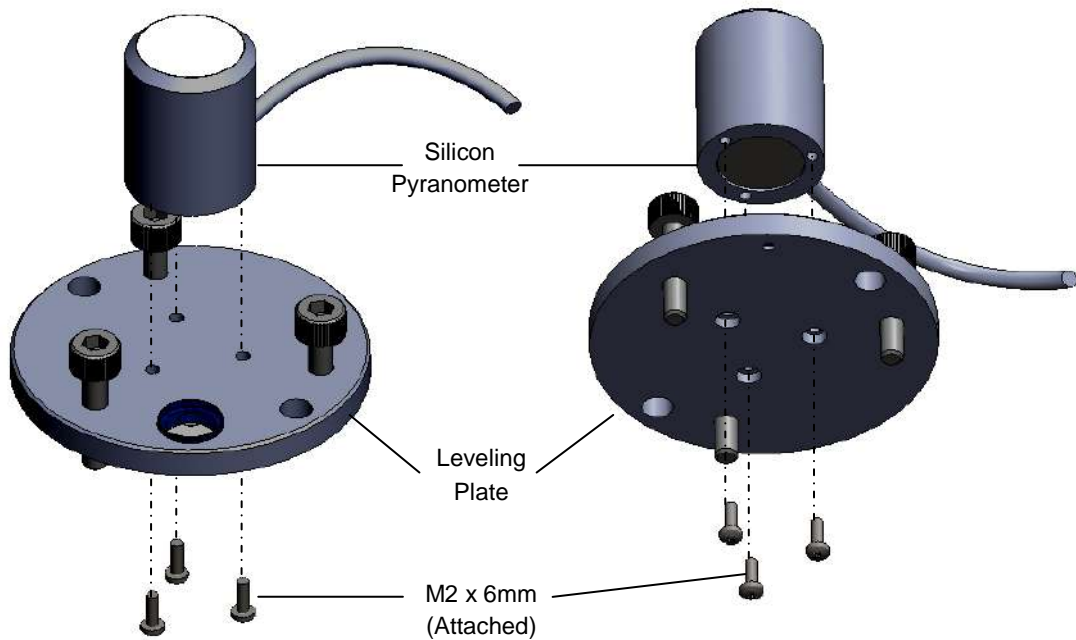

Figure 5-2. Attaching Leveling Plate (Optional)

---

## 5-3. Setup

In order to obtain representative measurements working with the ML-01, several criteria with respect to setup and mounting of the instruments have to be considered:

The ideal mounting position for solar sensors is a location which has a full hemispheric field-of-view without any obstructions (such as buildings, trees, and mountain). In practice, it might be difficult to find such locations. Therefore, some practical recommendations on how to minimize undesired effects of reflecting or obstructing surfaces are given next:

- Select a mounting position which it is free from obstructions at 5° above horizon.
- The setup location should be easily accessible for periodic maintenance (glass dome cleaning, desiccant replacement, etc.).
- Avoid surrounding towers, poles, walls or billboards with bright colors that can reflect solar radiation onto the pyranometer.
- A strong physical impact to the pyranometer can lead to product damage and/or may cause changes to the sensitivity.

### 1. Installing on Horizontal or Tilted Position

- 1) When installing the ML-01 without the optional leveling plate, three M2 screws must be prepared by user.  
Prepare three M2 screws that are 3~4mm longer than the installation base plate thickness which the pyranometer is mounted.
- 2) Check the installation base where the sensor has to be mounted and make sure it has two fixing holes with the appropriate pitch. (See [7-3. Dimension])
- 3) Setup the sensor with the signal cable facing the nearest Earth's pole. In the Northern hemisphere, the cable should be orientated North, in the Southern hemisphere, the cable should be orientated South.
- 4) [If optional Leveling Plate is used]  
Adjust the 3 leveling screws on the leveling plate, so that the air bubble in the spirit level will be positioned in the center of the circle on the spirit level. If the sensor is not leveled properly, the sensor readings are affected by cosine and azimuth errors. Periodically check the spirit level and adjust the sensor position if necessary.

[Installing in Tilted Position]

Ideally the sensor should be mounted to a tilted mounting base using the leveling plate with the 3 leveling feet.

Level the sensor on a leveled table in horizontal position before placing the sensor on the sloped mounting base.

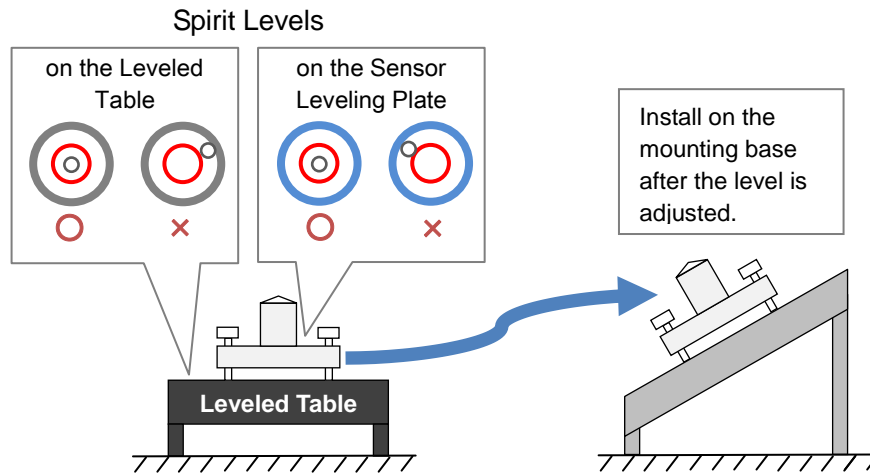

Figure 5-3. Installing in Tilted Position

- 5) Fasten the leveling plate to the tilted mounting base using the attached two bolts.  
Wrench and spanner (10mm) is required for fixing fastening the M6 fixing bolts

## 2. Wiring

To extend the cable life time, make sure that the cables are not exposed to direct sun light or rain/wind by lining the cable through a cable conduit. Cable vibrations will potentially cause noise on the output signal.

Fasten the cable so that the cable does not swing or move by wind blowing.

Exposure of the signal cable to excessive electromagnetic sources can cause noise on the output signal.

Therefore the cable should be lined at a safe distance from a potential source generating EM noise, such as a power electronics, high voltage lines or telecom antenna.

Strongly pulling the signal cable will break the cable connections; make sure the cable is not forcibly pulled during the installation.

---

## 5-4. Cable Connection

### 1. Connecting to Measuring Device

- 1) Connect the ML-01 signal cable ends to a measurement device or data logger. Polarities are as follow:

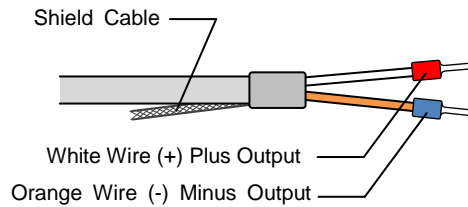

Figure 5-4. Signal cable Ends Polarity

- 2) Check the output voltage. If some noise is seen on the output voltage, connect the shield cable and minus (-) input terminal together.
- 3) Make sure to connect the cable with correct polarities to the measuring device input terminals. White wire with red terminal is (+), orange wire with blue terminal is (-). (It is recommended to use a measurement device with minimum 100k $\Omega$  input impedance).

### 2. Notes for Handling Cables

The sensor signal cable comes with standard length of 5m (directly connected to ML-01 body). In case the cable length is insufficient for your application, please request for desired length at the time of ordering. In case you want to extend the cable length use a shielded low noise cable.

(If approximately 10~20m cable is extended, use 0.5mm<sup>2</sup> x 2 pins shield cable).

---

## 5-5. Measurement

### 1. Calculation

The global solar irradiance in Watts per meter squared [ $W/m^2$ ] is obtained when the output voltage  $E$  [ $\mu V$ ] is divided by the sensitivity of the pyranometer  $S$  [ $\mu V/W \cdot m^{-2}$ ]. This calculation is expressed by the following formula:

$$I = \frac{E}{S}$$

$I$ : Measurement Value [ $W \cdot m^{-2}$ ]

$E$ : Sensor Output Voltage [ $\mu V(mV)$ ]

$S$ : Sensor Sensitivity [ $\mu V/W \cdot m^{-2}$ ]

\*The sensitivity  $S$  for the sensor is stated on the calibration certificate and the product label.

### 2. Measuring Device Requirements

Measurement range settings: If the measurement range can be selected on the data acquisition system, select the measurement range which can accurately measure the signal over a range of 0 to 100mV under the assumption that the global broad-band solar irradiance does not exceed  $1,400W/m^2$  (in both horizontal and tilted measurement positions) the signal level of the pyranometer output Voltage will remain below 70mV.

This maximum output Voltage can be calculated by multiplying the maximum solar irradiance with the calibration factor (e.g. when the sensitivity of the ML-01 pyranometer is about  $50\mu V/W \cdot m^{-2}$  or  $0.050mV/W \cdot m^{-2}$ , the maximum output voltage is about  $1,400W/m^2$  times  $0.050mV/W \cdot m^{-2} = 70mV$ ).

A Si photodiode detector is integrated in the ML-01 which generates a current proportional to the received solar radiation. A shunt resistor is applied across the detector junctions to convert the current output into a voltage.

Note: Make sure to use a measuring device with input impedance more than  $100k\Omega$  and resolution of  $50\mu V$  to detected radiation values of  $1 W/m^2$ .

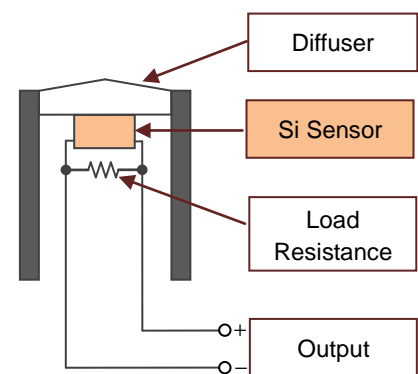

Figure 5-5. ML-01 Construction

## 6. Maintenance & Troubleshooting

### 6-1. Maintenance

EKO sensors will provide accurate measurement results if the diffuser and the condition of the instrument are maintained properly. Furthermore, regular maintenance and scheduled re-calibrations can extend the lifetime and precision. However, environmental conditions, such as for instruments mounted near highly frequented traffic lanes or airports, chemical industry, may have a deteriorating effect on the materials. Therefore, proper maintenance is needed and has to be adapted to the local environmental conditions.

The following table describes the common maintenance tasks that should be performed on a regular basis:

Table 6-1. Maintenance Items

Items Maintenance Item	Frequency	How To	Effect
Clean Diffuser	Several times per week (at least once per week)	Keep the diffuser clean by wiping it with a soft cloth.	If the diffuser gets soiled (by accumulation of dirt) the detector output will be affected due to a change in transmittance. This dirt can either be removed manually (not using alcohol) or it is washed off by rain (self cleaning effect).
Check Diffuser Condition	Weekly	Check for cracks and scratches on the diffuser and the rim.	May lead to water leakage due to rain/dew which causes damage of the detector inside the pyranometer.
Check Spirit Level Bubble	Weekly	Verify if the pyranometer is leveled by checking the bubble is in the center ring of spirit level. (When the pyranometer is setup in horizontal position)	If a pyranometer in the horizontal measurement position is not leveled correctly an additional cosine/azimuth error will be introduced.
Check Cable Condition	Weekly	Verify if the cable is properly connected, and how cable is lined; make sure the cable is not swinging by wind.	A disconnected cable will cause sporadic reading errors or failure of operation. If the cable is damaged, it may lead to noise or electric shock (ventilator AC power cable).
Check Setup Base Condition	Weekly	Check if the instrument is tightened properly to the mounting base plate and the base plate and/or table is securely fastened in a proper condition.	Loose instruments and/or mounting plates can lead to damages of the instruments and/or injury.

---

---

## 6-2. Calibration Method

It is recommended to recalibrate the instrument once every 2 years. For further information about the calibration and recalibration of your solar sensors, please contact EKO.

### **[Indoor Calibration Procedure]**

The ML-01 was calibrated conform the international secondary calibration methods applied to PV reference cells. It was calibrated at 25°C against an AM1.5G / 1000W/m<sup>2</sup> radiation source provided by AAA Solar Simulator (IEC 60904-3 Spectral distribution). During the calibration sequence, the incidence irradiance [W/m<sup>2</sup>] is alternately measured with a calibrated ML-01 sensor (EKO standard) which is used as reference. The sensitivity figure of the production ML-01 is determined by calculating the output ratio multiplied by the sensitivity figure of the reference model.

### *Traceability*

The ML-01 reference sensor maintained at EKO is traceable to the international radiation scale called WRR (World Radiometric Reference) maintained at PMOD (Davos, Switzerland). The ML-01 reference sensor is calibrated by direct comparison against the secondary standard reference pyranometer MS-802 and 2 units of internal reference pyranometers, which were calibrated against the PMO-6 absolute cavity according to the continuous sun-un-shade method [according to ISO 9846 Calibration of a pyranometer using a pyrhelimeter).

The absolute cavity (PMO6) maintained at EKO is directly traceable to WRR by comparing against WRR every 5 years.

See Appendix A-2 for traceability diagram.

---

---

## 6-3. Troubleshooting

Check the following items in case of trouble with the instrument. If any questions should remain, contact EKO for further technical support.

Table 6-2. Troubleshooting

Failure	Action
There is no output	Make sure that the sensor cable is connected properly to the measurement device. To verify the sensor connection, measure the impedance of signal cable (between the "+" and the "-" wires) and check if the measured impedance is within the proper range as shown on the specification.
	Check whether the measurement range setup on the measuring device is appropriate.
Output value is too low	The diffuser maybe covered by rain drops or got soiled. Clean the diffuser with a soft cloth.

# 7. Specification

## 7-1. Main Unit

The spectral response for ML-01 is shown in graph in the Appendix A-1 section.

Table 7-1. Main Unit Specification

Characteristics		Details
Measurement Range		0 ~ 2000 W/m <sup>2</sup>
Spectral range		400 ~ 1100 nm
Response time		< 1ms
Sensitivity(approx.)		50 uV/W · m <sup>-2</sup>
Output (0~100mV Range)		~100mV
Internal Resistance (approx.)		48Ω
Operating Temperature		-30 ~ +70°C
Temperature Dependency		<0.15%/°C
Directional Response (0° ~ 80°)		<±5%
Field of view		180°
Stability		<±2% per year
Dimension	Sensor only	φ22 x 28.5mm
	With Leveling Plate	φ60 x 43.5mm
Weight	Sensor only	30g
	With Leveling Plate	75g

## 7-2. Cables

Table 7-2 Cable Specifications

Cables	Details	Terminal	Wire	Output
Signal cable	Diameter: 0.18mm <sup>2</sup> x 2pins φ3.2mm Cable end: pin terminal	Red Blue	White Orange	(+) Plus (-) Minus

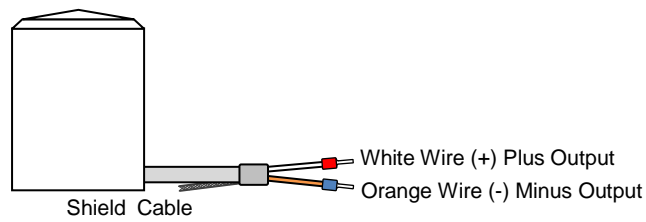

Figure 7-1. Signal cable

## 7-3. Dimensions

### 1. ML-01 Dimension (without Leveling Plate)

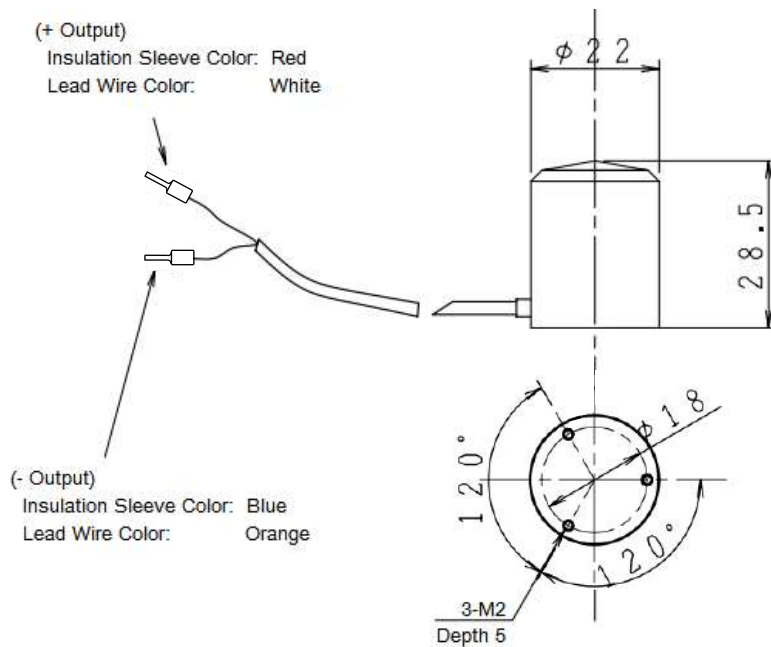

Figure 7-2. Outer Dimensions of Sensor

## 2. ML-01 Dimension (with optional Leveling Plate)

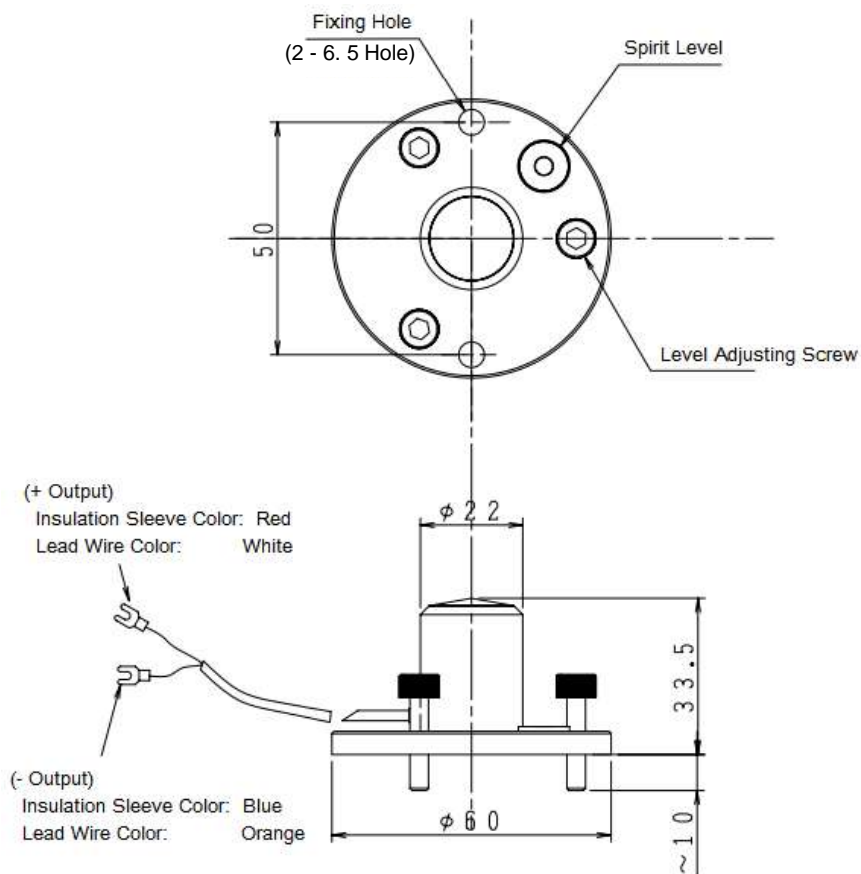

Figure 7-3. Outer Dimensions of Sensor and Leveling Plate

## 7-4. Accessories List

Table 7-4. Accessories List

Option Items	Remarks
Leveling Plate	Sensor Mounting Screws (M2x6mm, 3pcs & extra 3pcs for spare) Leveling Screws(Bolts: M5x20mm, 3pcs) Fixing bolts (Bolts: M6x50mm, 2pcs, Washers: M6, 4pcs, Nuts: M6, 2pcs)
Cable length	5m (Optional 10m, 30m, 50m)

# APPENDIX

## A-1. Spectral & Directional Response Characteristics

Below are the typical values of the spectral response and directional response.

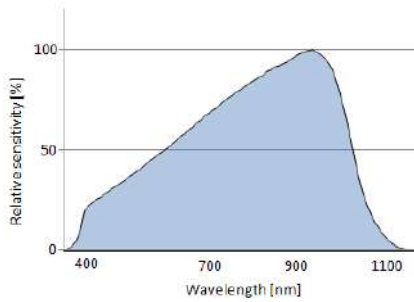

Figure A-1. Spectral Response (Typical Value)

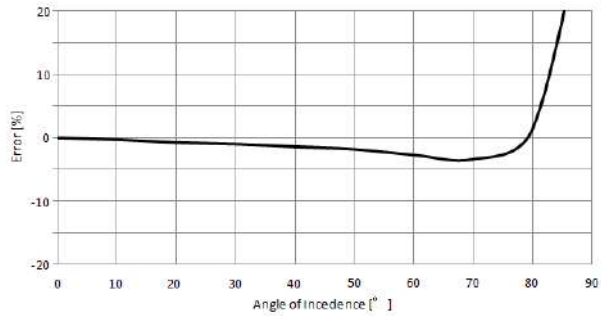

Figure A-2. Directional Response (Typical Value)

## A-2. Traceability

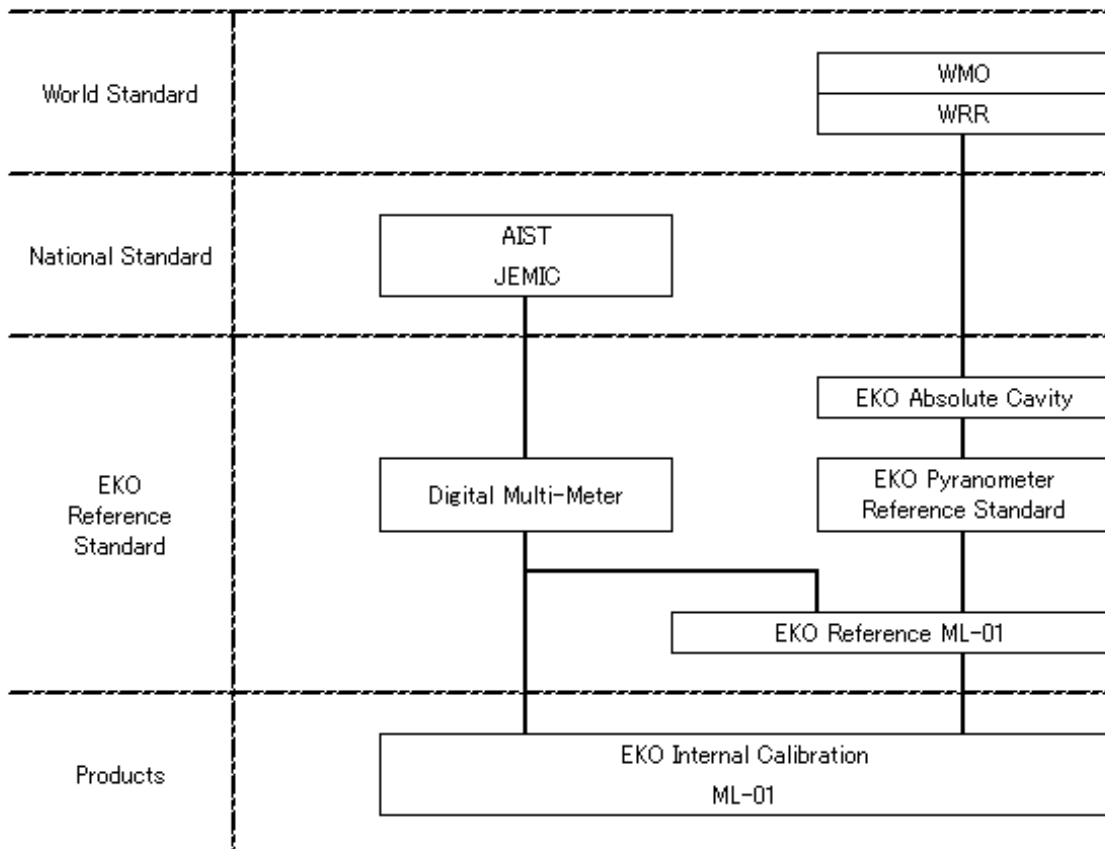

Figure A-3. Traceability Diagram



**EKO Asia, Oceania**

1-21-8 Hatagaya,  
Shibuya-ku, Tokyo  
151-0072 Japan  
P. +81.3.3469.6711  
F. +81.3.3469.6719  
info@eko.co.jp  
www.eko.co.jp

**EKO North America**

95 South Market Street,  
Suite 300, San Jose,  
CA 95113, USA  
P. +1-408-977-7751  
F. +1-408-977-7741  
info@eko-usa.com  
www.eko-usa.com

**EKO Europe,  
Middle East, Africa,  
South America**

Lulofsstraat 55, Unit 32,  
2521 AL, Den Haag,  
The Netherlands  
P. +31 (0)70 3050117  
F. +31 (0)70 3840607  
info@eko-eu.com  
www.eko-eu.com